

Ahsanullah University of Science and Technology
Department of Electrical and Electronic Engineering

LABORATORY MANUAL
FOR
ELECTRICAL AND ELECTRONIC SESSIONAL COURSES

Student Name :
Student ID :

Course no : EEE-2106
Course Title : Energy Conversion I

For the students of
Department of Electrical and Electronic Engineering
2nd Year, 1st Semester

Experiment No.	Name of the Experiments
01	Study of a Single-Phase Transformer.
02	Performance Tests on Single Phase Transformer.
03	To determine the regulation of a transformer under different power factor.
04	Parallel operation of transformers.
05	Study of Three-Phase Transformers.
06	Study the efficiency of Three-Phase Transformers.
07	Determination of Circuit Parameters of a 3 Phase Induction Motor.
08	Load Characteristics of a 3 Phase Slip Ring Induction Motor.
09	To study the speed control of a 3 Phase induction motor by using Variable frequency drive (VFD).
10	Study of a 1-ϕ induction motor.
11	Performance test of a 1-ϕ induction motor.

Experiment no: **1**
 Experiment name: **Study of a Single-Phase Transformer.**

Introduction:

A transformer is a static device by means of which electric power in one circuit is transferred into electric power in another circuit of the same frequency. It can raise or lower voltage in the circuit with a corresponding decrease or increase in current. So the volt-ampere rating of two circuits remains same. The simple structure of a 1- ϕ transformer is shown below:

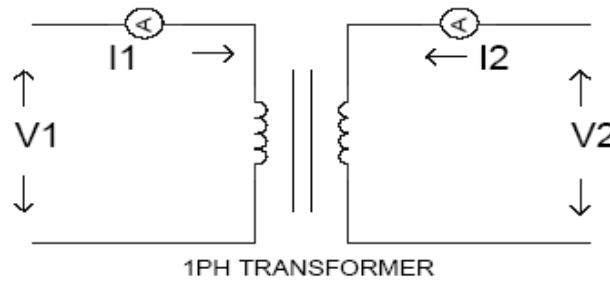

Fig: Simple structure of a 1- ϕ transformer

Ignoring losses, the output power=input power

$$V_1 * I_1 = V_2 * I_2$$

$$\text{i.e. } V_1/V_2 = I_2/I_1 \text{(1)}$$

Again the induced voltage in the transformer is directly proportional to the no of turns surrounding the transformer windings. So

$$V_1 \propto N_1 \quad \text{and} \quad V_2 \propto N_2$$

$$V/N = \text{constant}$$

$$V_1/N_1 = V_2/N_2 \quad \text{So } V_1/V_2 = N_1/N_2 \text{(2)}$$

Combining these two equations, (1) and (2) we get

$$V_1/V_2 = I_2/I_1 = N_1/N_2$$

Where N_1/N_2 is called the transformation ratio or simply turns ratio of a transformer

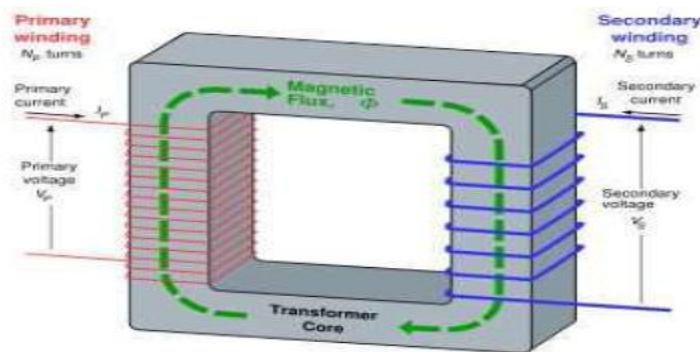

Equipments:

1. Universal Power Supply Module
2. 1PH Transformer
3. AC Ammeter Module 0-1A
4. AC Voltmeter Module 0-250 V
5. Resistive Load
6. 1PH Wattmeter Module

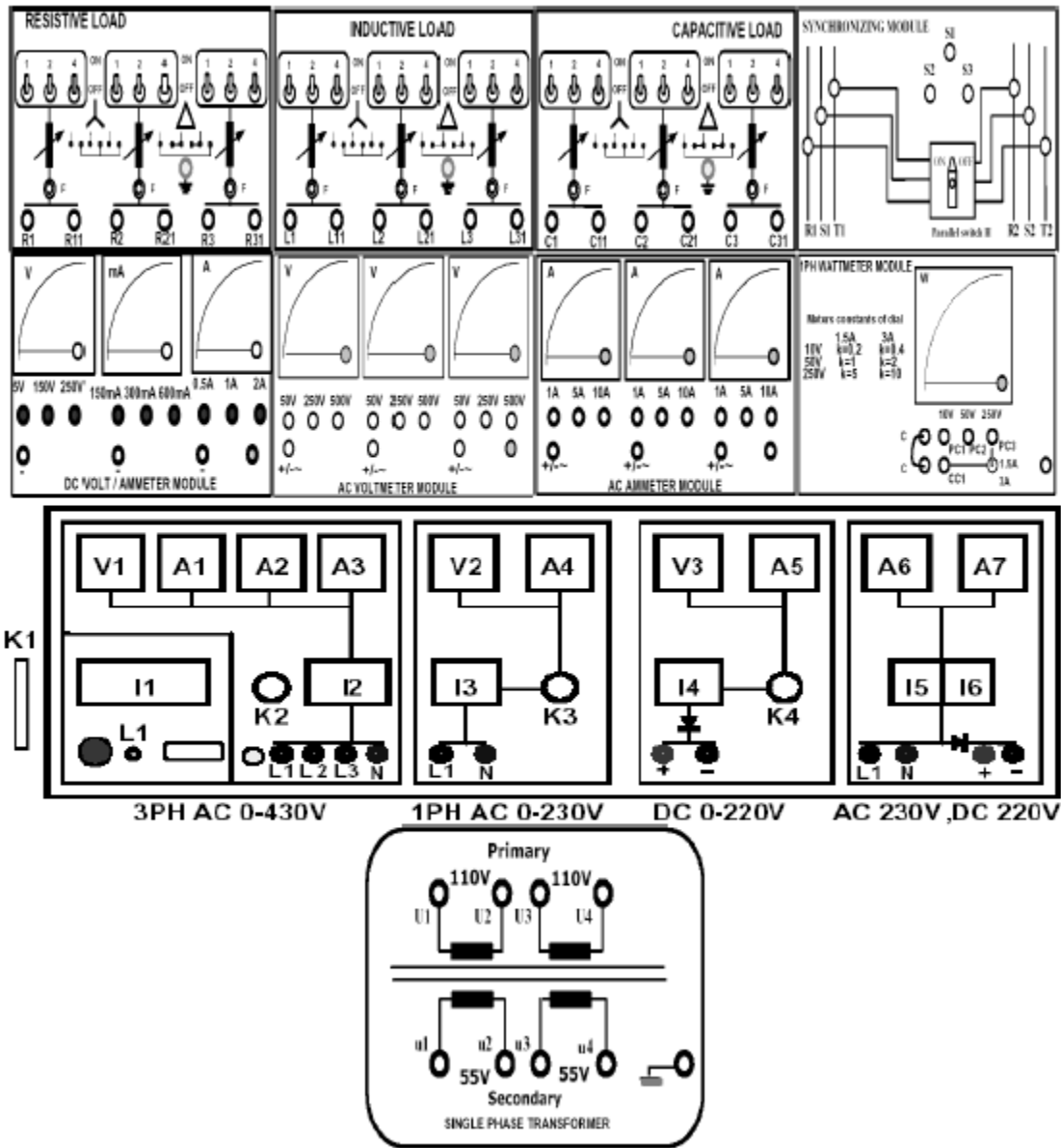

Ratio Test:

For a transformer, we know, the transformation ratio is given by

$$\frac{V_1}{V_2} = \frac{I_2}{I_1} = \frac{N_1}{N_2}$$

We shall determine the transformation ratio by measuring the voltages and currents both in the primary and secondary side.

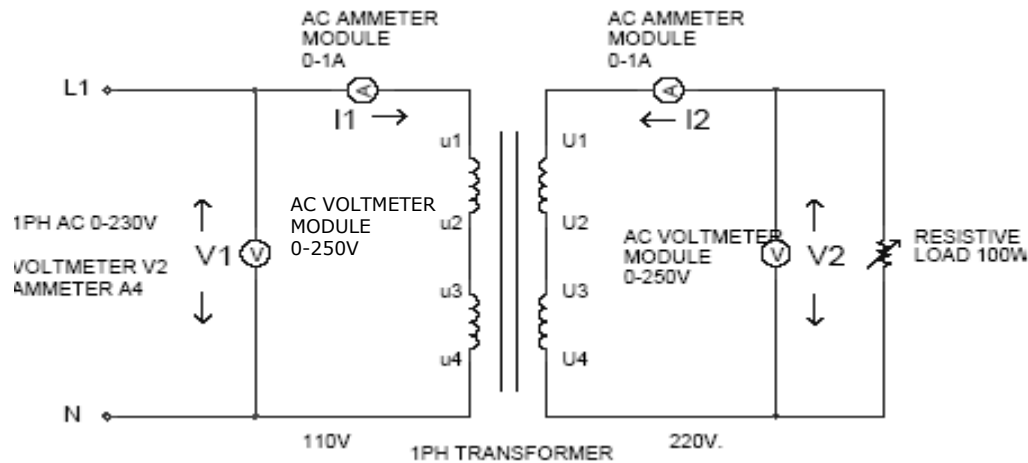

Procedure:

1. Make sure all the switches (I1, I2, I3, I4, I5, I6) on the Power Supply are turned OFF (downwards).
2. Make sure all the variable knobs (K1, K3, K4) are at the min, counter clock wise (CCW) position.
3. Make sure all the switches (1,2,4) of the Resistive Load Module are OFF (downwards)
4. Make connections according to the above diagram.
5. Verify the connection by your Lab Teacher
6. Turn ON Switch I1 (upwards).
7. Turn Key K2 Clock Wise Once, the Indicator Lamp L1 becomes Green.
8. Make sure the 3PH supply Voltmeter V1 reads 400V.
9. Turn ON switch I3 (upwards).
10. Slowly Increase 1PH AC Voltage to 110V, Turn Knob K3 CW upto a position when, Voltmeter V2 reads 110V .
11. Increase the Resistive Load sequentially by using two points R1 and R11 by turning ON the switches (1,2,4) of the Resistive Load Module mounted on the left most block.
12. Note the voltages and currents both in the primary and secondary sides from the AC Voltmeter & Ammeter Module.

Transformer on No-load:

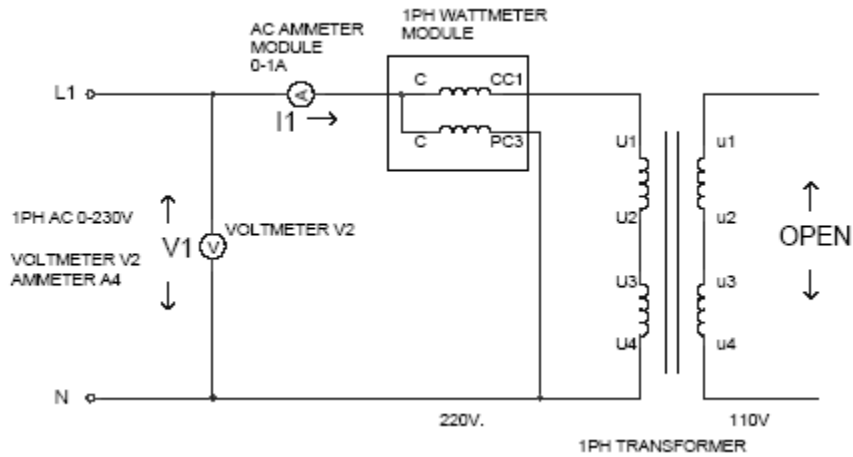

Procedure:

1. Make sure all the switches (I1, I2, I3, I4, I5, I6) on the Power Supply are turned OFF (downwards).
2. Make sure all the variable knobs (K1, K3, K4) are at the min, counter clock wise (CCW) position.
3. Make connections according to the above diagram.
4. Verify the connection by your Lab Teacher
5. Turn ON Switch I1 (upwards).
6. Turn Key K2 Clock Wise Once, the Indicator Lamp L1 becomes Green.
7. Make sure the 3PH supply Voltmeter V1 reads 400V.
8. Turn Knob K3 at min (CCW)
9. Turn ON switch I3 (upwards).
10. Slowly Increase 1PH AC Voltage to 220V, Turn Knob K3 CW, Voltmeter V2 reads 220V .
11. Note the voltages and currents in the primary side from the AC Voltmeter & Ammeter Module.

Report:

1. What effects are produced in a transformer by change in voltage?
2. Does transformer work on DC? Give proper explanation.

Group No:
Roll no:

Data Sheet

Ratio test:

$V_1 =$ $V_2 =$ $I_1 =$ $I_2 =$

Calculate Transformation ratio:

Transformer on No-load:

$I_{oc} =$ $V_{oc} =$ $W_{oc} =$

Calculation:

Core loss = $W_{oc} =$

$\Phi_0 =$

Working component of current, $I_w = I_{oc} \cos\Phi_0 =$

Magnetizing component of current, $I_\mu = I_{oc} \sin\Phi_0 =$

Signature of the Lab teacher:

Experiment no: **2**
Experiment name: **Performance Tests on Single Phase Transformer.**

Introduction:

The performances of a transformer can be calculated on the basis of its equivalent circuit, which contains four main parameters:

The equivalent resistance R_{01} referred to primary or R_{02} referred secondary side.

Equivalent leakage reactance X_{01} referred to primary or secondary X_{02} .

Core Loss Conductance G_0 or Resistances R_0 .

Magnetizing Susceptance B_0 Or Reactance X_0 .

These parameters can be determined by the following two tests:

1. Open-Circuit test
2. Short-circuit test



Equipments:

1. Universal Power Supply Module
2. 1PH Transformer
3. AC Ammeter Module 0-1A
4. AC Voltmeter Module 0-250 V
5. 1PH Wattmeter Module
6. Connecting Cables

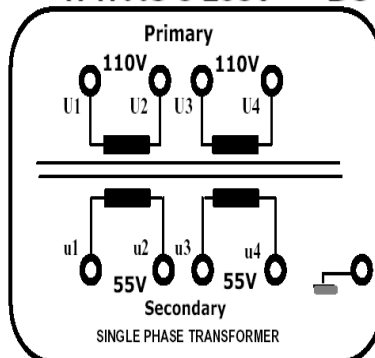
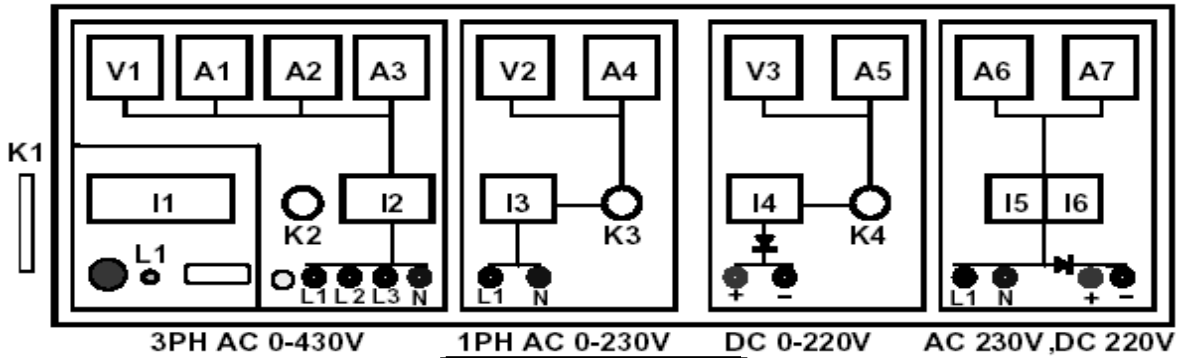
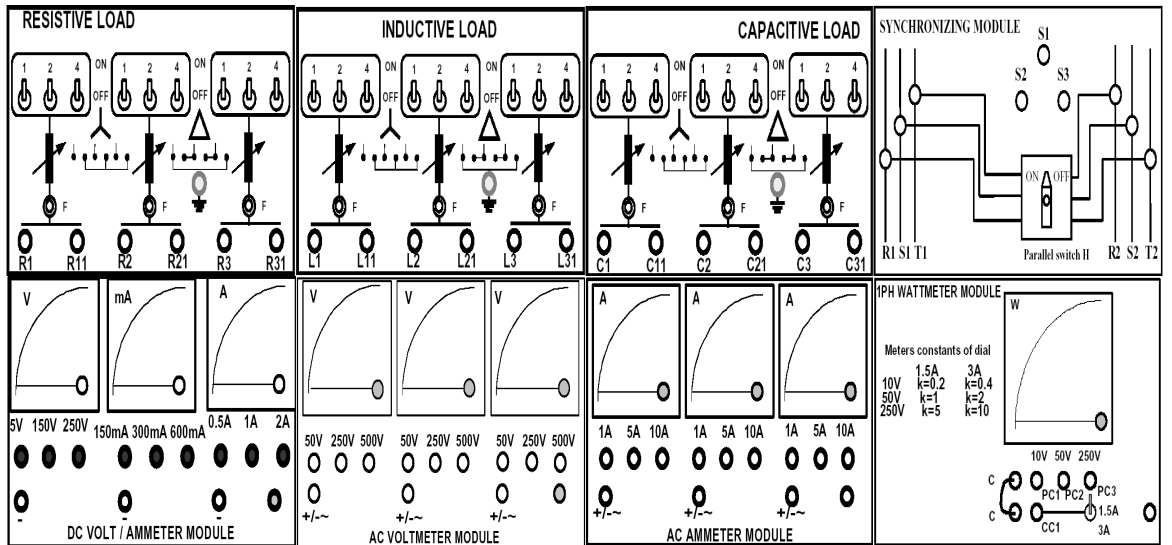

Open-Circuit Test:

This test determines no-load loss or core loss of the transformer. The no-load current I_0 helps to find X_0 and R_0 . The circuit arrangement for this test is shown below:

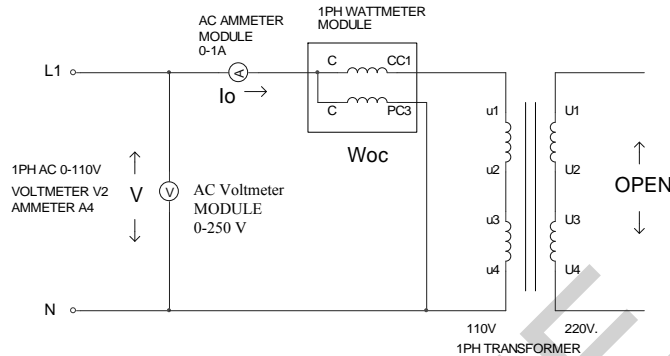

From the wattmeter, voltmeter, ammeter readings -----

$$W_{OC} = V * I_0 * \cos\phi_0 \quad \text{i.e.} \quad \cos\phi_0 = W_{OC} / (V * I_0)$$

Where $\cos\phi_0$ is called the primary power factor under no-load condition.

The no-load current has two components.

1. **Magnetizing current, $I_\mu = I_0 * \sin\phi_0$**
2. **Working component, $I_w = I_0 * \cos\phi_0$** , this current is also called iron loss component.

So core resistance referred to L.T side is $R_0 = V / I_w$ and Core reactance referred to L.T side is $X_0 = V / I_\mu$

Procedure:

1. Make sure all the switches (I1, I2, I3, I4, I5, I6) on the Power Supply are turned OFF (downwards).
2. Make sure all the variable knobs (K3, K4) are at the min, counter clock wise (CCW) position.
3. Make connections according to the above diagram.
4. Verify the connection by your Lab Teacher
5. Turn ON Switch I1 (upwards).
6. Turn Key K2 Clock Wise Once, the Indicator Lamp L1 becomes Green.
7. Turn Knob K3 at min (CCW)
8. Turn ON switch I3 (upwards).
9. Slowly Increase 1PH AC Voltage to **110V**, Turn Knob K3 CW
10. Note the Voltages, Currents on the AC Voltmeter & Ammeter, Power on the Wattmeter Module

2. Short Circuit Test: This test determines copper loss in the transformer. Finding this loss the regulation of the transformer can be determined. The circuit arrangement of this test is shown below:

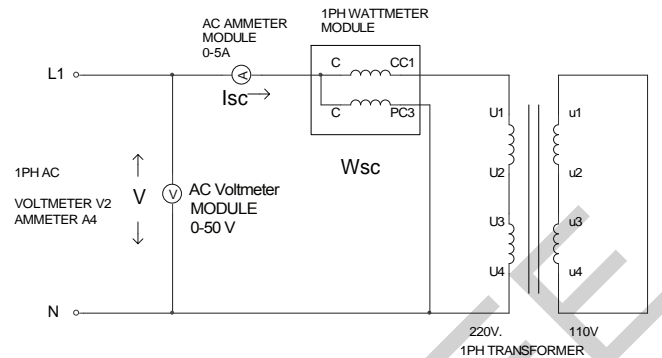

From the wattmeter, voltmeter, ammeter readings, we get

$$W_{CU} = W_{SC} = R_{01} * I_{SC}^2 \quad \text{i.e. } R_{01} = W_{SC} / I_{SC}^2$$

$$X_{01} = \sqrt{((V/I_{SC})^2 - R_{01}^2)}$$

Procedure:

1. Make sure all the switches (I1, I2, I3, I4, I5, I6) on the Power Supply are turned OFF (downwards).
2. Make sure all the variable knobs (K3, K4) are at the min, counter clock wise (CCW) position.
3. Make connections according to the above diagram.
4. Verify the connection by your Lab Teacher
5. Turn ON Switch I1 (upwards).
6. Turn Key K2 Clock Wise Once, the Indicator Lamp L1 becomes Green.
7. Turn Knob K3 at min (CCW)
8. Turn ON switch I3 (upwards).
9. **Carefully increase the voltage till the rated current (300VA ÷ 220V = 1.36A) flows through the HT, Turn Knob K3 CW**
10. Note the readings on AC Voltmeter, Ammeter and Wattmeter Module

***** For each case write down the data on data sheet.**

Report

1. Draw the equivalent circuit diagram ref. to H.T. side and L.T. side.
2. Why were instruments placed on the H.T. side for short circuit test?
3. Why is it assumed that during short circuit test, all the losses are copper losses?
4. Why the rating of transformer is rated in KVA?

Group No:
Roll no:

Data Sheet

Open Circuit Test

$$I_{OC} = \quad V_{OC} = \quad W_{OC} =$$

Short Circuit Test

$$I_{SC} = \quad V_{SC} = \quad W_{SC} =$$

Calculation

$$\text{Core loss} = W_{OC} =$$

$$\Phi_0 =$$

$$I_W = I_{OC} \cos\Phi_0 =$$

$$I_\mu = I_{OC} \sin\Phi_0 =$$

$$\text{Core resistance (ref. to H.T. side)} = \frac{V_{OC}}{I_W} =$$

$$\text{Core reactance (ref. to H.T. side)} = \frac{V_{OC}}{I_\mu} =$$

$$\text{Copper loss} = W_{Cu} = W_{SC} =$$

$$\text{Equivalent Resistance (ref. to H.T. side)} = R_{01} = \frac{W_{SC}}{I_{SC}^2} =$$

$$\text{Equivalent Reactance (ref. to H.T. side)} = X_{01} = \sqrt{(V_{SC}/I_{SC})^2 - R_{01}^2}$$

Signature of the Lab teacher:

Experiment no: 3
Experiment name: To determine the regulation of a transformer under different power factor.

Introduction:

Regulation is an indication of voltage changes due to change in load. Any equipment is said to have good regulation if this change of voltage is less. It is defined as

$$\% R = \frac{V_{N.L.} - V_{F.L.}}{V_{F.L.}} \times 100$$

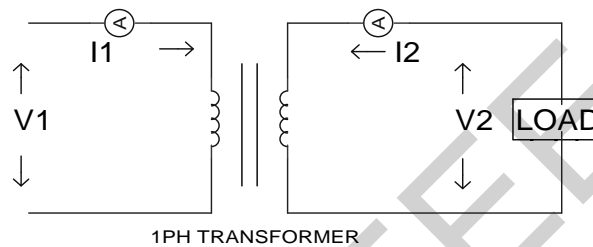

For a transformer, for constant primary voltage as load increases, the voltage at the load decreases, as there is voltage drop due to internal resistance and reactance of the transformer. If we know the resistance and reactance of the transformer, its regulation can be determined under various load conditions.

Equipments:

1. Universal Power Supply Module
2. 1PH Transformer
3. AC Ammeter Module 0-1A
4. AC Voltmeter Module 0-250 V
5. 1PH Wattmeter Module
6. Resistive Load Module
7. Inductive Load Module
8. Capacitive Load Module
9. Connecting Cables

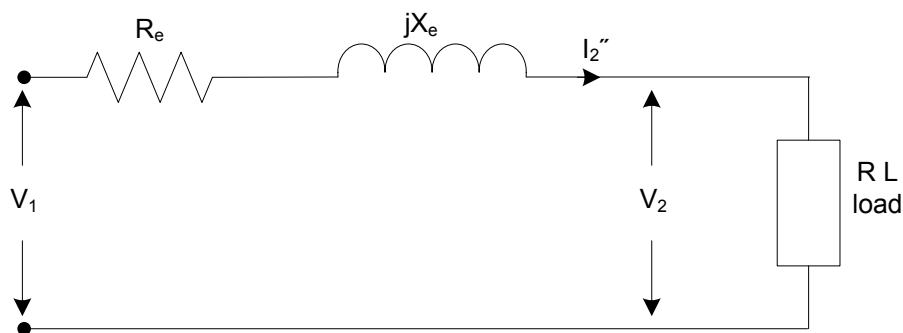

(a) Equivalent Circuit

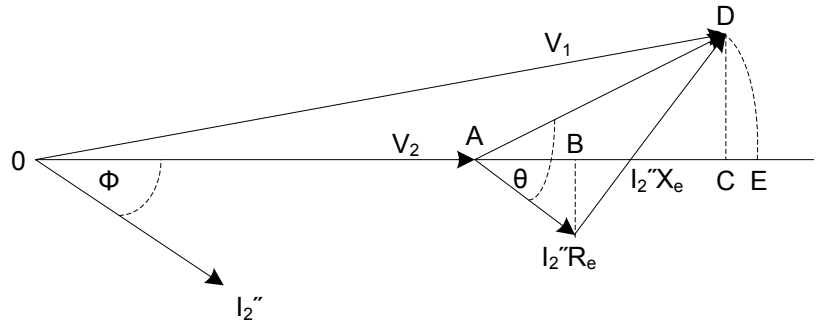

(b) Phasor Diagram

Connection Diagram:

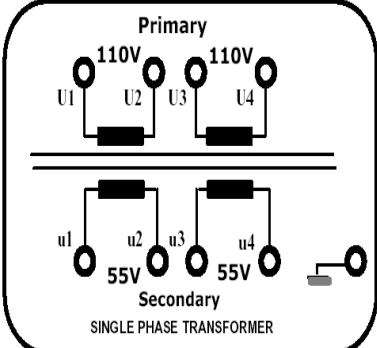
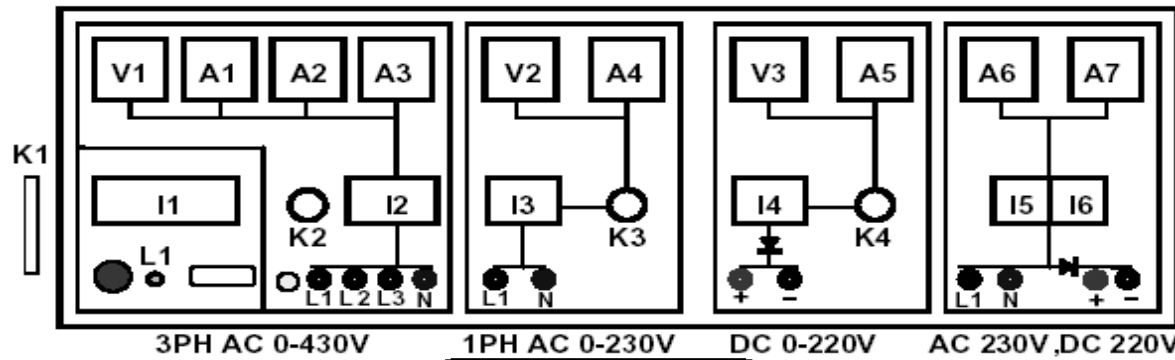
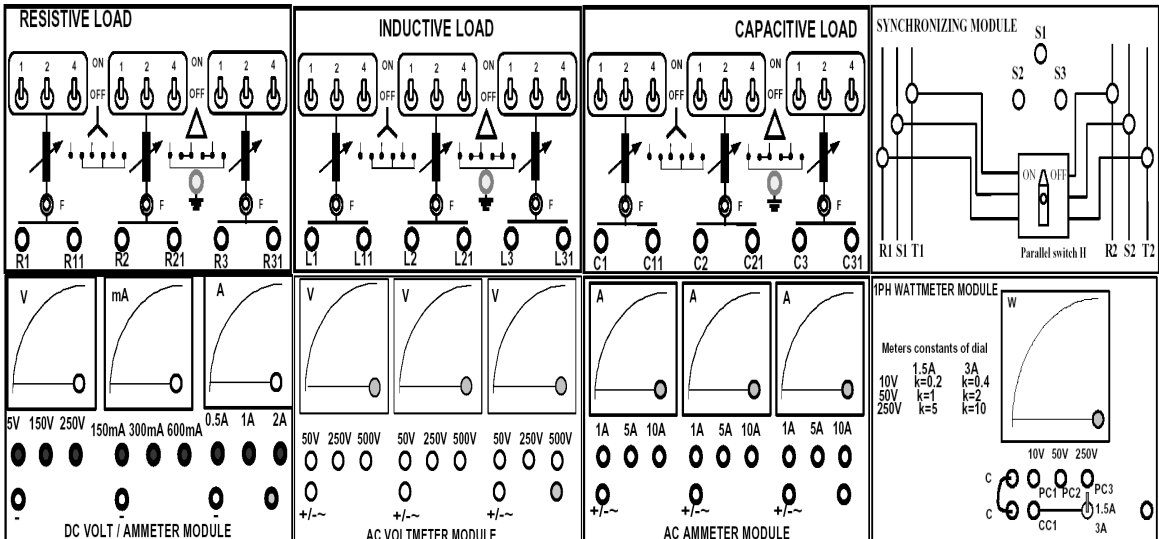

Short Circuit Test:

From the Short Circuit Test done in Experiment 2, note the value of R_{01} , X_{01} referred to the H.T. side.

With Resistive Load:

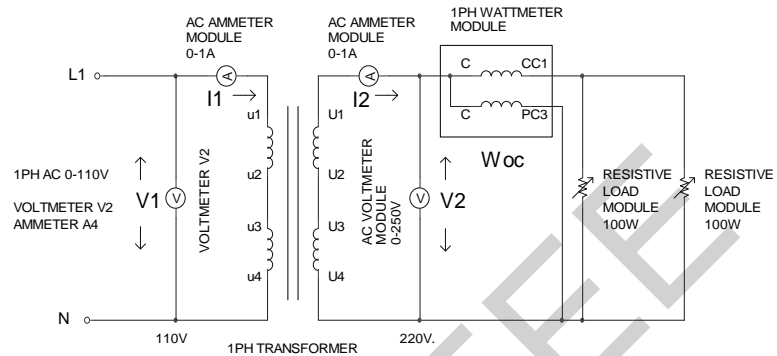

Procedure:

1. Make sure all the switches (I1, I2, I3, I4, I5, I6) on the Power Supply are turned OFF (downwards).
2. Make sure all the variable knobs (K3, K4) are at the min, counter clock wise (CCW) position.
3. Make connections according to the above diagram.
4. Verify the connection by your Lab Teacher
5. Turn ON Switch I1 (upwards).
6. Turn Key K2 Clock Wise Once, the Indicator Lamp L1 becomes Green.
7. Turn Knob K3 at min (CCW)
8. Turn ON switch I3 (upwards).
9. Keep all the Loads at OFF position
10. Apply voltage **110V** on the LT side.
11. Note the readings on AC Voltmeter, Ammeter and Wattmeter Module
12. Now turn ON all the Loads
13. Note the readings on AC Voltmeter, Ammeter and Wattmeter Module

With R-L Load:

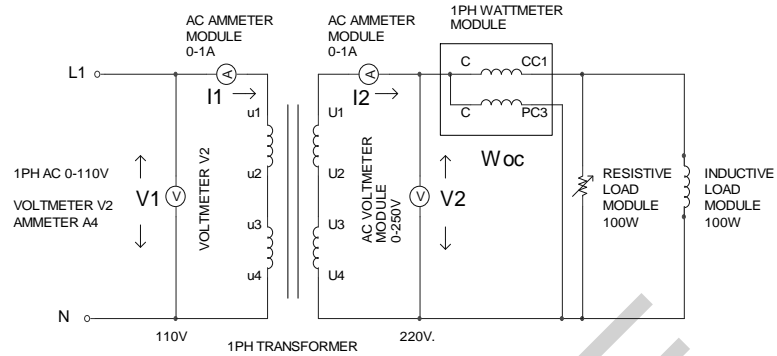

Procedure:

1. Follow the procedure mentioned on Resistive Load for the above Diagram

With R-C Load:

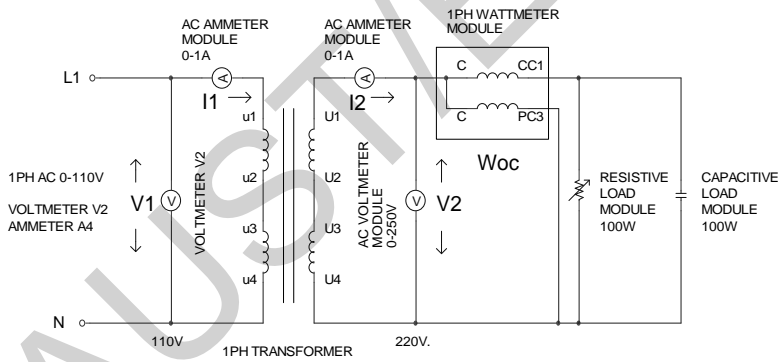

Procedure:

1. Follow the procedure mentioned on Resistive Load for the above Diagram

Report:

Draw the vector diagrams under unity, lagging and leading pf and calculate analytically the regulation in each case. Compare the value of regulation found analytically with that of experimental value.

Comment on the regulation under leading pf is it something different? Comment on this value.

Group No:
Roll no:

Data Sheet

Short circuit test

$W_{sc} =$ $I_{sc} =$ V_{sc}

Calculate

Equivalent Resistance (ref. to H.T. side) = $R_{01} = \frac{W_{sc}}{I_{sc}^2} =$

Equivalent Reactance (ref. to H.T. side) = $X_{01} = \sqrt{(V_{sc}/I_{sc})^2 - R_{01}^2}$

With Resistive Load

Terminal Voltage = Load current =

With R-L Load

Terminal Voltage = Load current = Load power =

With R-C Load

Terminal Voltage = Load current = Load power =

Signature of the lab Teacher

Experiment no: 4
Experiment name: Parallel operation of transformers.

Introduction:

When in a power system the demand for load increases, a single transformer may not be able to supply the extra load. In that case, another transformer is connected in parallel with the existing transformer to share the load. In order to make two transformers parallel, some conditions have to be fulfilled. These are:

- 1) Terminal voltages on the primary and secondary side should be identical.
- 2) The relative polarities on the primary and secondary sides should be identical.
- 3) Preferably R/X ratio of both the transformers should be same.
- 4) Primary windings of the transformer should be suitable for the supply system voltage and frequency.

Equipments:

1. 1PH Transformer 2 pieces
2. AC Ammeter Module 0-1A
3. AC Voltmeter Module 0-250 V
4. DC ammeter (0 to 600 mA)
5. Load 100 watts - 2 pieces.
6. Clamp-on-meter -1 piece
7. DC Supply – 9 V

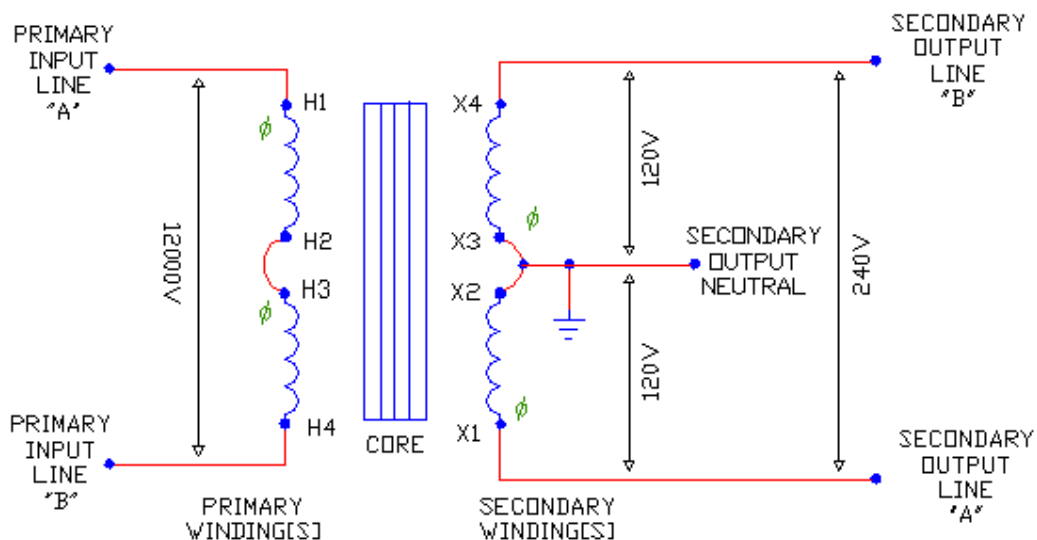
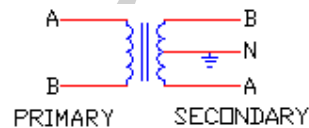

Connection Diagram:

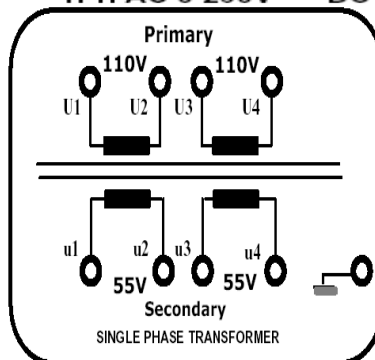
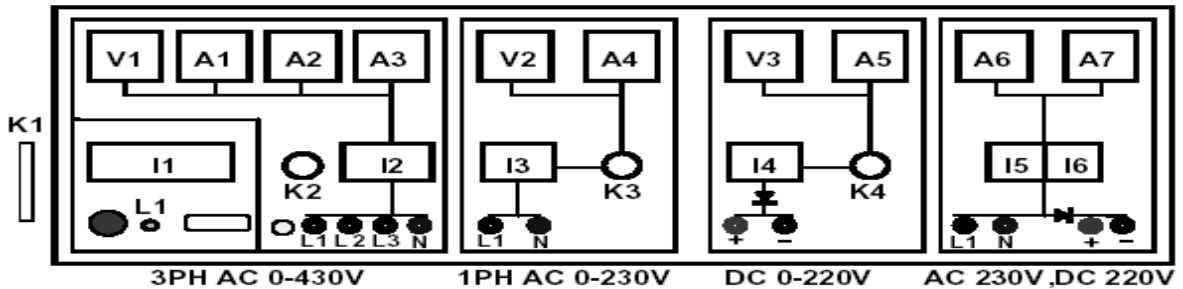
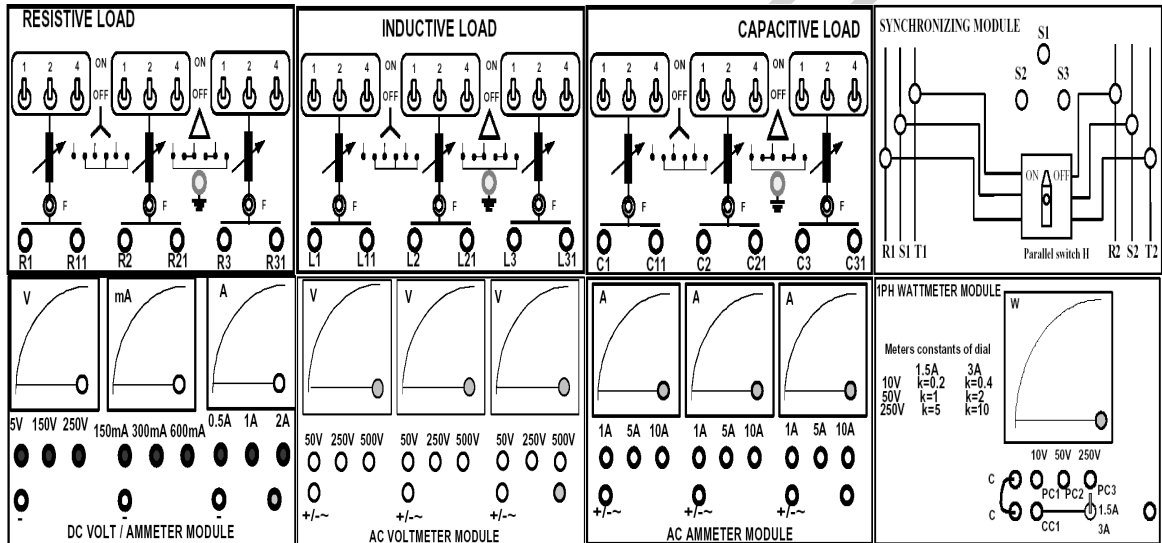
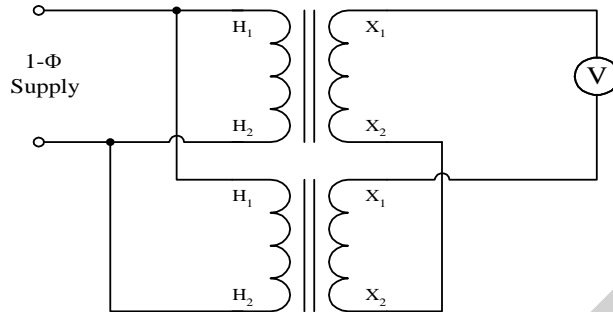

Procedure:

1. Select two 1- ϕ transformers of identical manufacturer.
2. On the secondary side of the transformer, determine R and X with an R-L-C meter.
3. Determination of Relative Polarity:

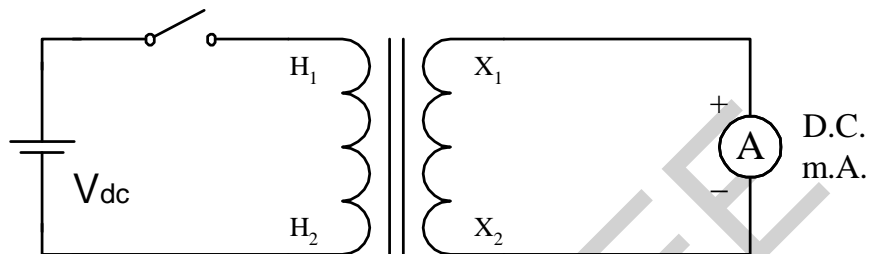

Connect a D.C. mA with polarity as shown on the secondary side, and a battery through a switch on the primary side. Push the switch (give a kick). If the mA deflects in the positive direction, then H_1 and X_1 have the same mode of winding. Repeat the step for TR2 and confirm that the modes of windings are identical.

(If not, report to the teacher.)

4. Connection for Parallel Operation:

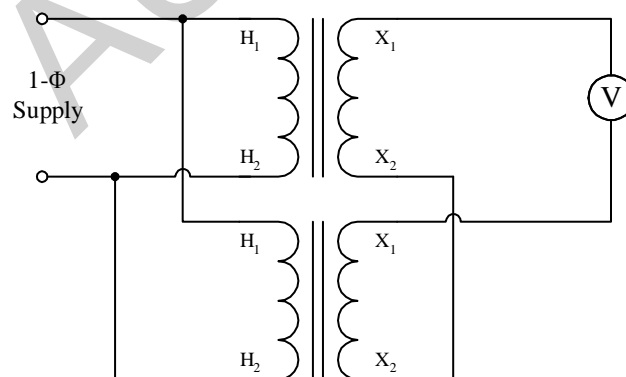

- a) Connect a voltmeter and connect the transformers as shown. If the polarities are correct, the voltmeter should read zero.

b) Disconnect the supply, remove the voltmeter and connect the two secondary terminals (X_1 , X_1) of TR1 and TR2. With a clamp-on-meter, check if there is any circulating current. If there is any, note this circulating current.

5. Now, re-connect TR1 and TR2 as in step 4(a). On the secondary side, connect 2 load of 100W each.

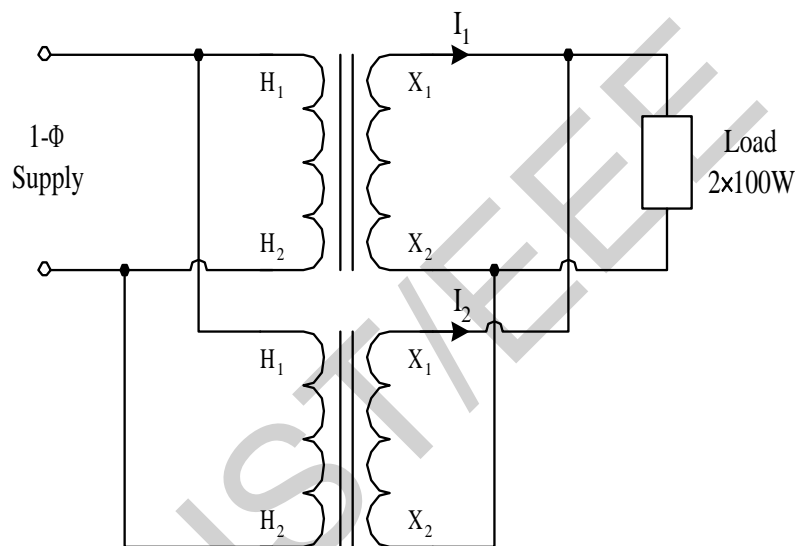

With clamp-on-meter, determine the currents supplied by TR1 and TR2

Report:

1. Discuss on the value of circulating current found in step 4(c).
2. Why is parallel operation necessary? Why is relative polarity test necessary for parallel operation?
3. Why the voltmeter gives zero reading if the polarities are same at step 4(a)?

Group No:
Roll no:

Data Sheet

For TR1: R1 = X1 =

For TR2: R2 = X2 =

Voltmeter reading on step 4:

clamp-on-meter reading on step 5:

Currents supplied by TR1 =

Currents supplied by TR2 =

Signature of the lab Teacher

Experiment no: 5
Experiment name: Study of Three-Phase Transformers.

Introduction:

A transformer is a static device by means of which electric power in one circuit is transferred into electric power in another circuit of the same frequency. It can raise or lower voltage in the circuit with a corresponding decrease or increase in current. So the volt-ampere rating of two circuits remains same. As the volt-ampere rating of two sides are same so

$$V_1 * I_1 = V_2 * I_2$$

i.e. $V_1/V_2 = I_2/I_1$ (1)

Again the induced voltage in the transformer is directly proportional to the no of turns surrounding the transformer windings. So

$$V_1 \propto N_1 \quad \text{and} \quad V_2 \propto N_2$$

i.e. $V_1/V_2 = N_1/N_2$ (2)

Combining these two equations, (1) and (2) we get

$$V_1/V_2 = I_2/I_1 = N_1/N_2$$

Where N_1/N_2 is called the transformation ratio or simply turns ratio of a transformer.



Equipments:

1. 3PH Transformer 1 pieces
2. AC Ammeter Module 0-1A
3. AC Voltmeter Module 0-250 V
4. DC ammeter (0 to 600 mA)
5. Clamp-on-meter -1 piece
6. Connecting Cables

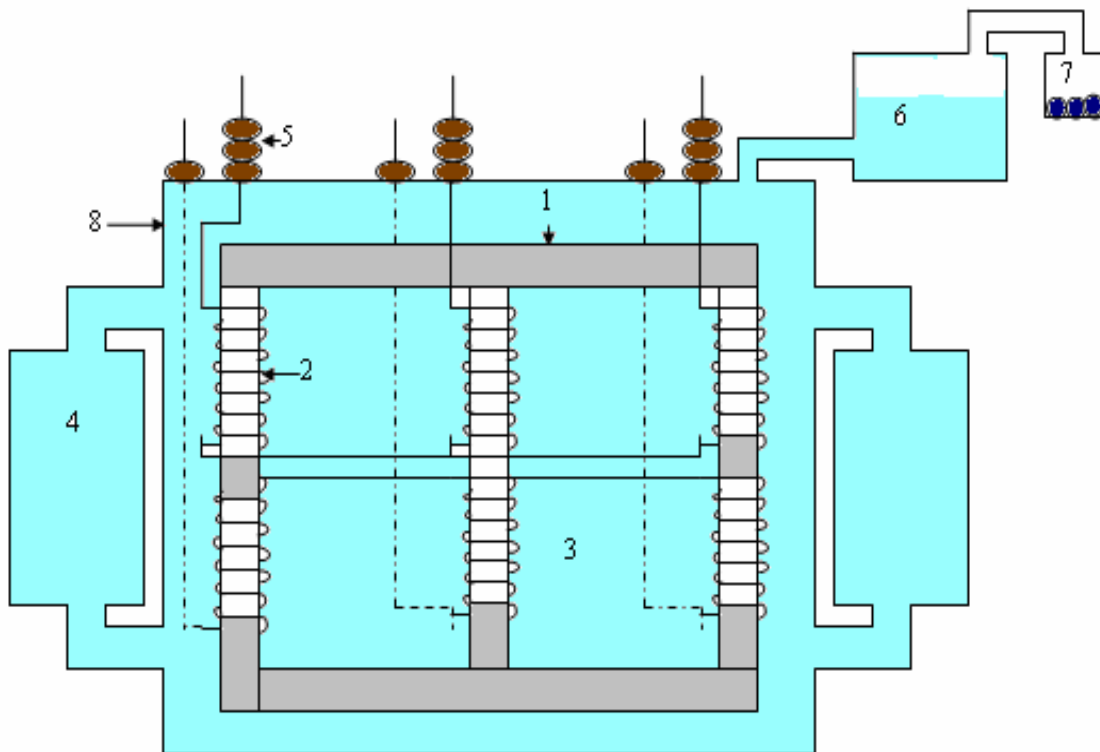

Important parts of a three-phase transformer

1. **Core**- Core is made by laminated silicon steel
2. **Coil**- Coil(winding) is simply made by insulated copper wire
3. **Transformer oil (mineral oil)** - Transformer oil has two functions one is to provide necessary insulation for the core and coli and other one is to absorb the heat produce by the power loss of transformer.
4. **Fin**- Cooling system for heated transformer oil.
5. **Bushing**- Bushing is used to connect the coils (primary and secondary) to the outer circuit for rigid fitting and avoiding the contact with transformer tank.
6. **Conservator**- Conservator holds the excess oil when the oil gets expanded.
7. **Breather with Silica gel**- Breather is used to pass the air inward and outward of a transformer through conservator and silica gel absorb the moisture of air.
8. **Transformer tank**- Transformer tank houses core, coil and oil.

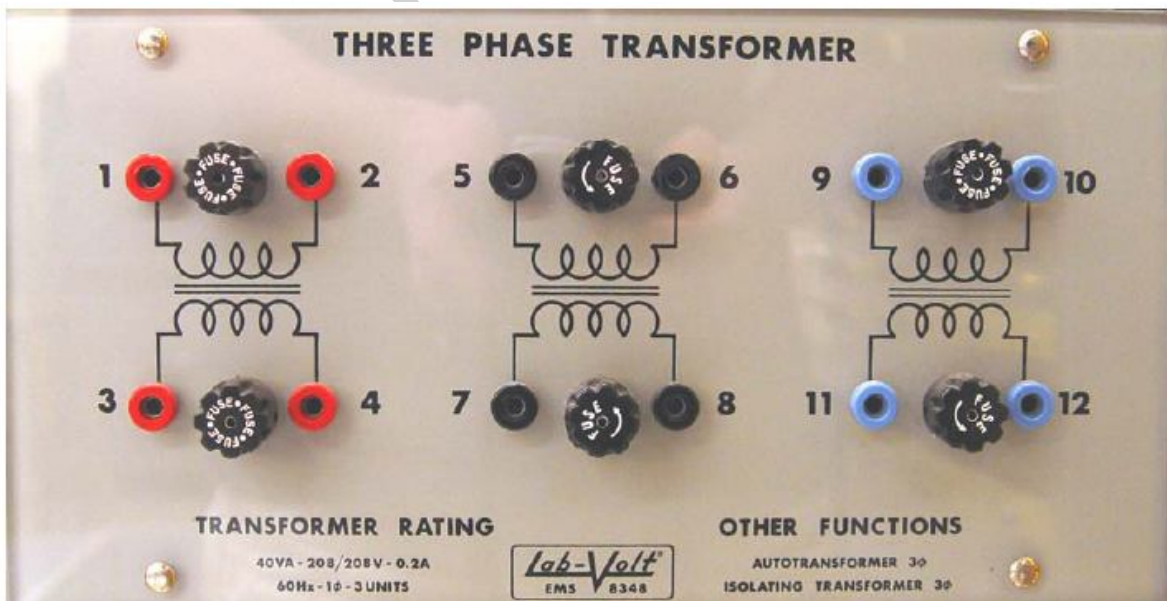
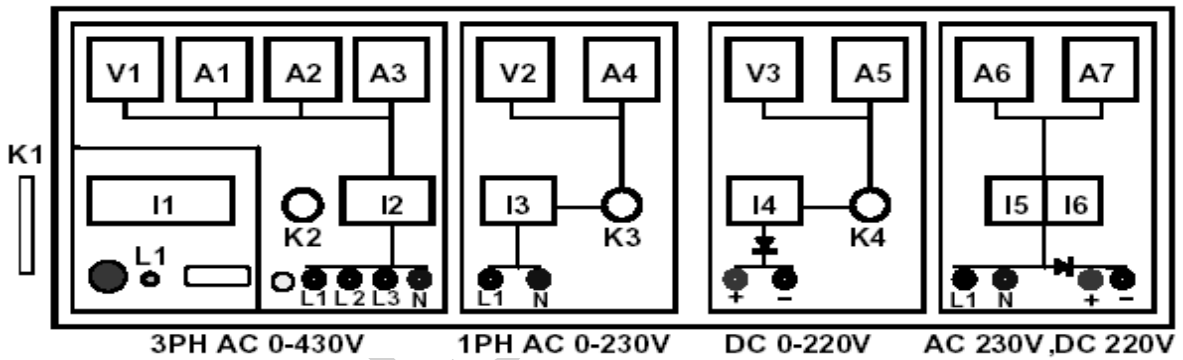
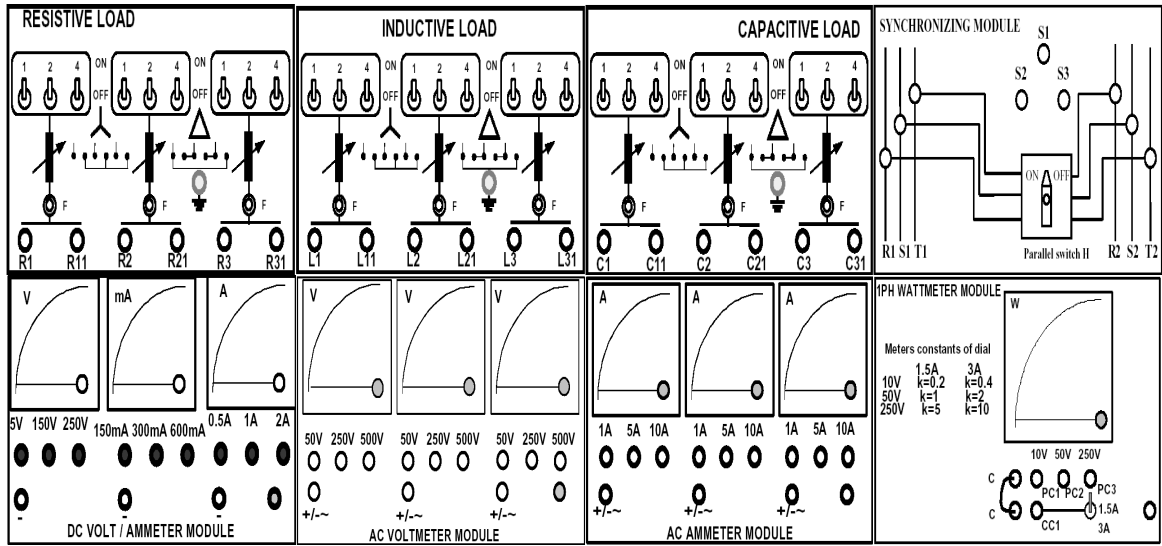

Connection to form three-phase transformer:

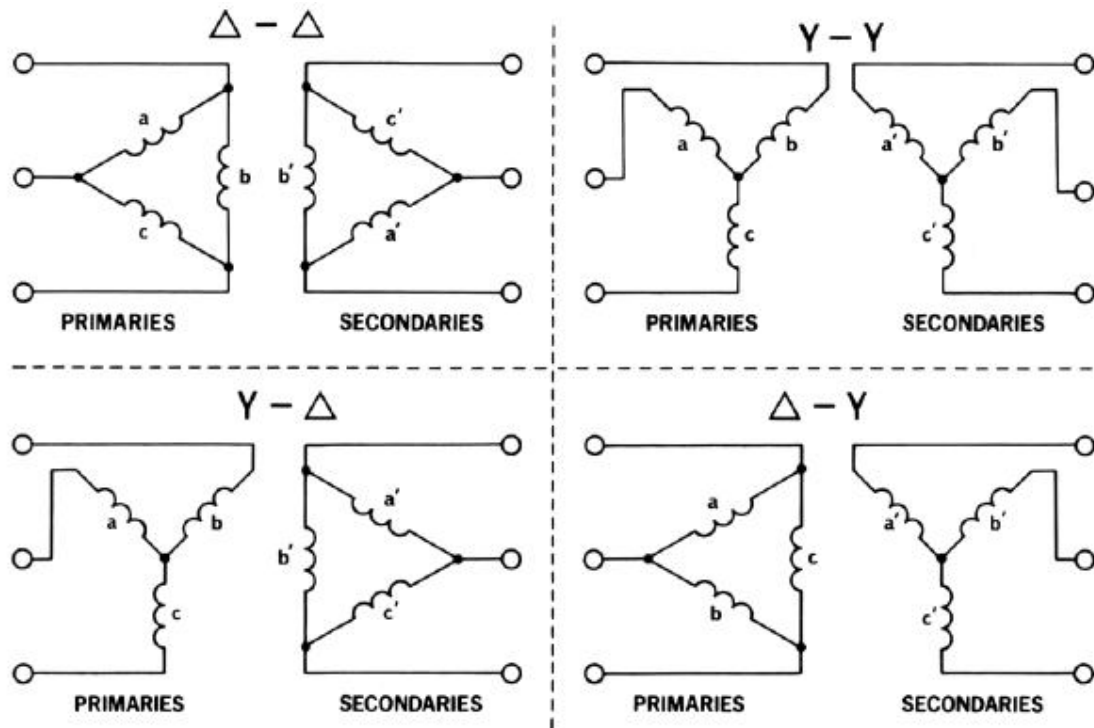

Procedure:

1. Select a 3- ϕ transformer of identical manufacturer.
2. Make sure all the switches (I1, I2, I3, I4, I5, I6) on the Power Supply are turned OFF (downwards).
3. Make sure all the variable knobs (K3, K4) are at the min, counter clock wise (CCW) position.
4. Make connections according to the above diagram.
5. Verify the various part of the transformer and make their combinations with the help of your Lab Teacher.
6. Now verify the advantages for each type of combination.

Signature of the lab Teacher

Experiment no: **6**
Experiment name: **Study of the efficiency of Three-Phase Transformers.**

Introduction:

In an ideal transformer, the power in the secondary windings is exactly equal to the power in the primary windings. This is true for transformers with a coefficient of coupling of 1.0 (complete coupling) and no internal losses. In real transformers, however, losses lead to secondary power being less than the primary power. The degree to which a real transformer approaches the ideal conditions is called the efficiency of the transformer:

$$\text{Efficiency (\%)} = \frac{P_{out}}{P_{in}} \cdot 100\%$$

where P_{out} and P_{in} are the real output and the input powers. Apparent and reactive powers are not used in efficiency calculations. Transformers may be connected in parallel to supply currents greater than rated for each transformer. Two requirements must be satisfied:

- 1) The windings to be connected in parallel must have identical output ratings;
- 2) The windings to be connected in parallel must have identical polarities.

Severe damage may be made to circuitry if these requirements are not satisfied.

Single-phase transformers can be connected to form 3-phase transformer banks for 3-phase power systems. Four common methods of connecting three transformers for 3-phase circuits are Δ - Δ , Y Y, Y- Δ , and Δ -Y connections.



Equipments:

1. 1PH Transformer 2 pieces
2. AC Ammeter Module 0-1A
3. AC Voltmeter Module 0-250 V
4. DC ammeter (0 to 600 mA)
5. Load 100 watts - 2 pieces.
6. Clamp-on-meter -1 piece
7. DC Supply – 9 V
8. Connecting Cables

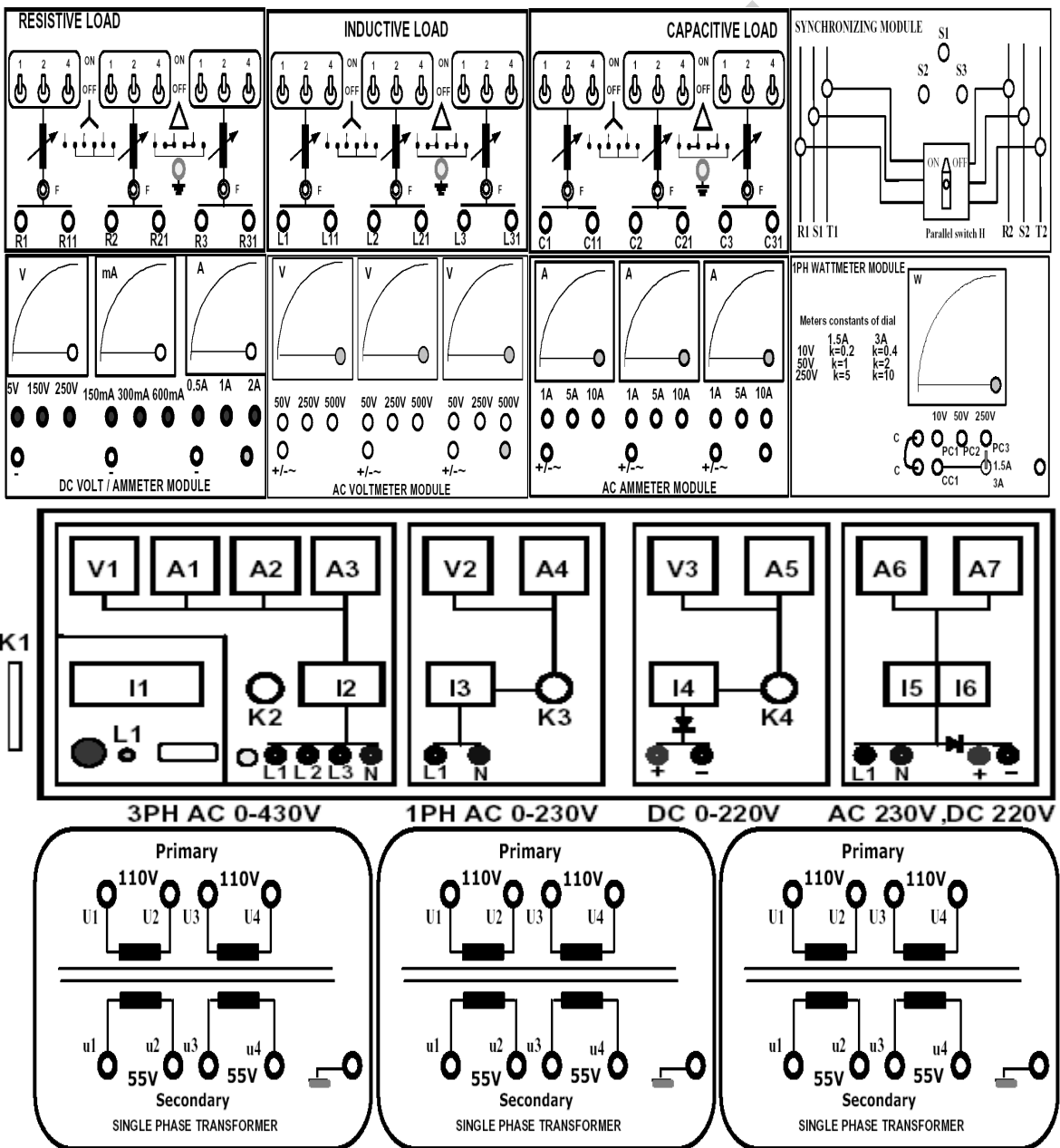

Connection to form three-phase transformer:

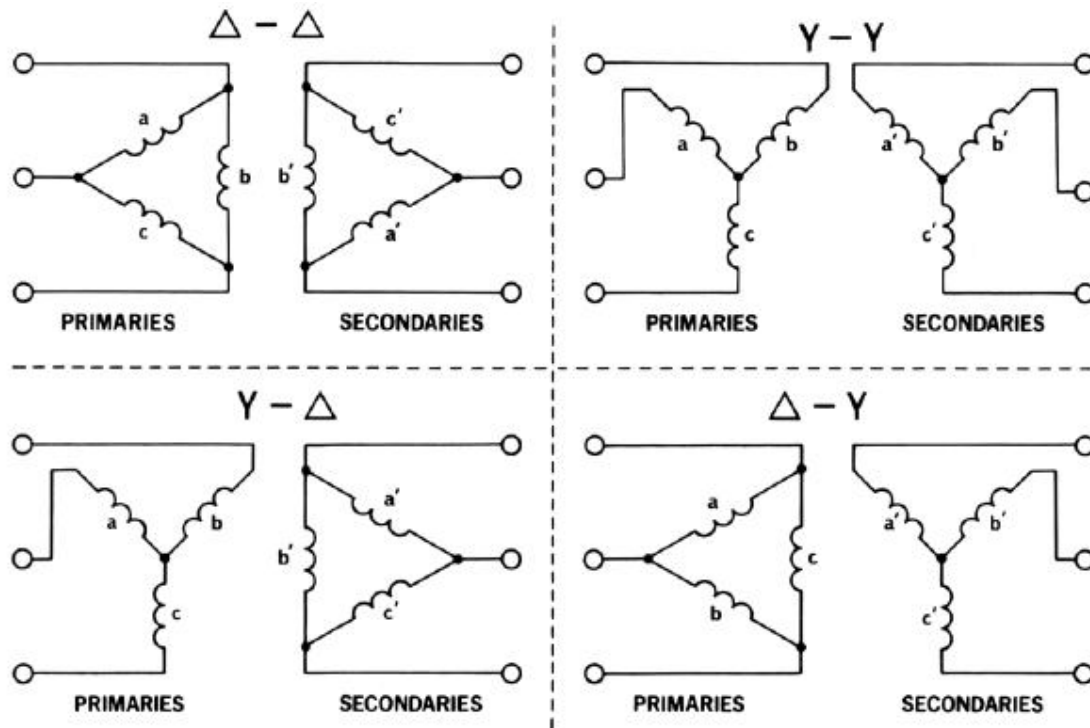

Procedure:

1. Select three 1- ϕ transformers of identical manufacturer.
2. Make sure all the switches (I1, I2, I3, I4, I5, I6) on the Power Supply are turned OFF (downwards).
3. Make sure all the variable knobs (K3, K4) are at the min, counter clock wise (CCW) position.
4. Make connections according to the above diagram.
5. Verify the connection by your Lab Teacher
6. Now verify the advantages for each type of combination.
7. Keep all the Loads at OFF position
8. Apply voltage **110V** on the LT side.
9. Note the readings on AC Voltmeter, Ammeter and Wattmeter Module.
10. Now turn ON all the Loads.
11. Note the readings on AC Voltmeter, Ammeter and Wattmeter Module.
12. With constant resistive load determine the efficiency for each combination.

Group No: Roll no:

Data Sheet

With Δ - Δ connection

Terminal Voltage = Load current = Load power =

With Y-Y connection

Terminal Voltage = Load current = Load power =

With Y- Δ connection

Terminal Voltage = Load current = Load power =

With Δ -Y connection

Terminal Voltage = Load current = Load power =

Signature of the lab Teacher

Experiment no: **7**
Experiment name: **Determination of Circuit Parameters of a 3 Phase Induction Motor.**

Introduction:

For an induction motor the equivalent circuit referred to secondary (rotor) is basically an R-X circuit with variable s (slip). As load varies, s varies so the magnitude of R varies.

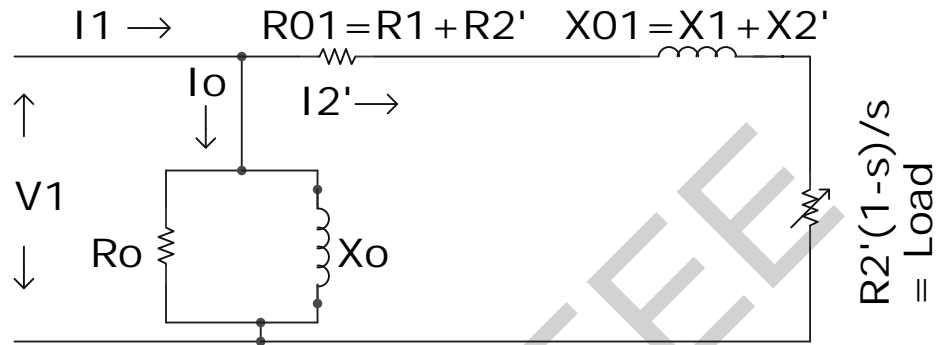

The following tests are required to determine the circuit constants.

1. No- load test
2. Blocked rotor test

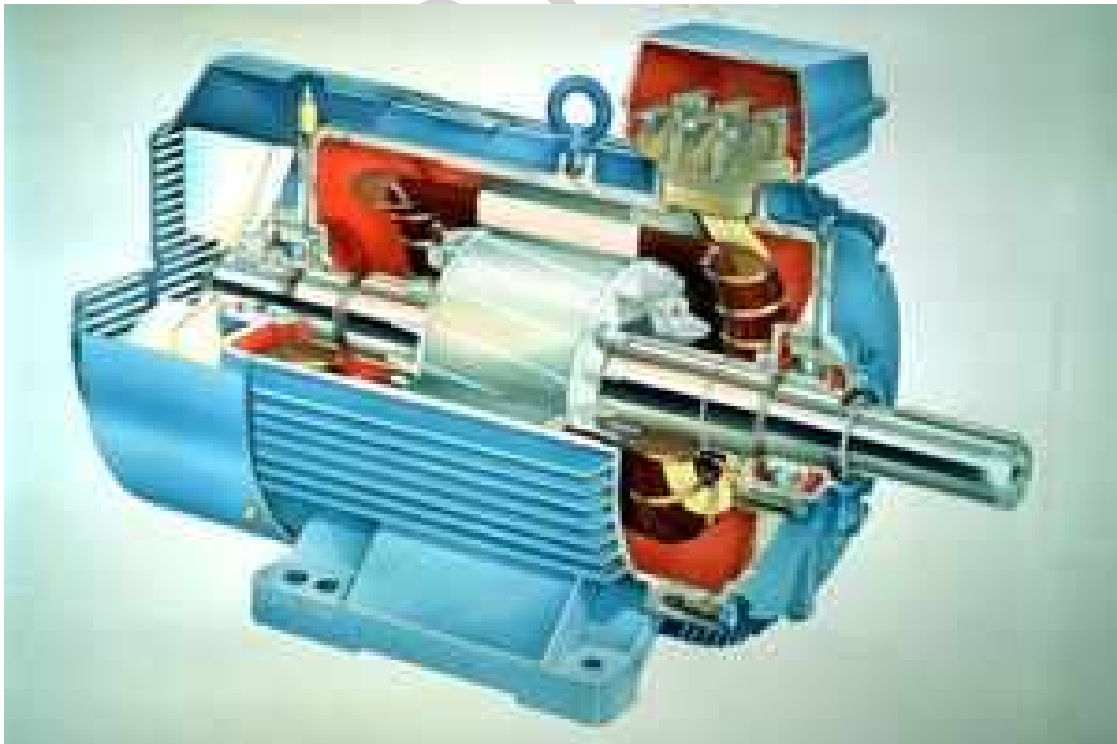

Equipments:

1. Universal Power Supply Module
2. 3 Phase Squirrel Cage Induction Motor
3. AC Ammeter Module 0-1A
4. AC Voltmeter Module 0-250 V
5. 1PH Wattmeter Module
6. Connecting Cables

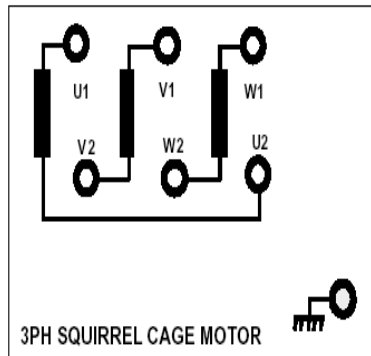
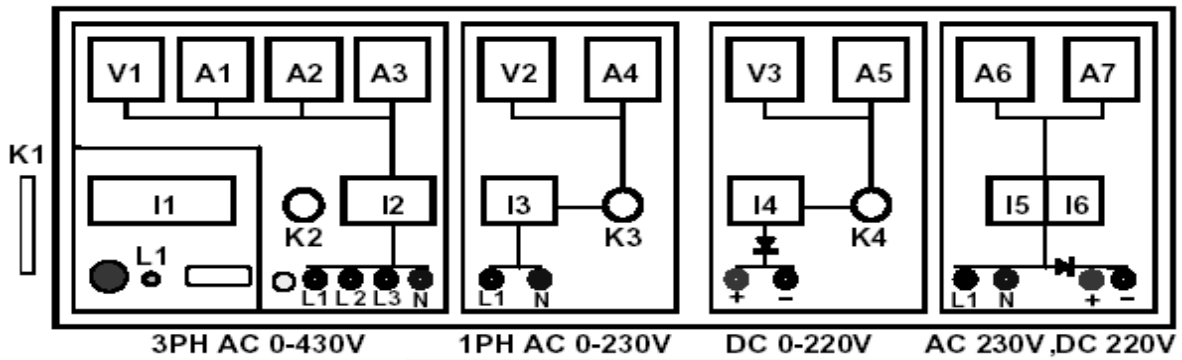
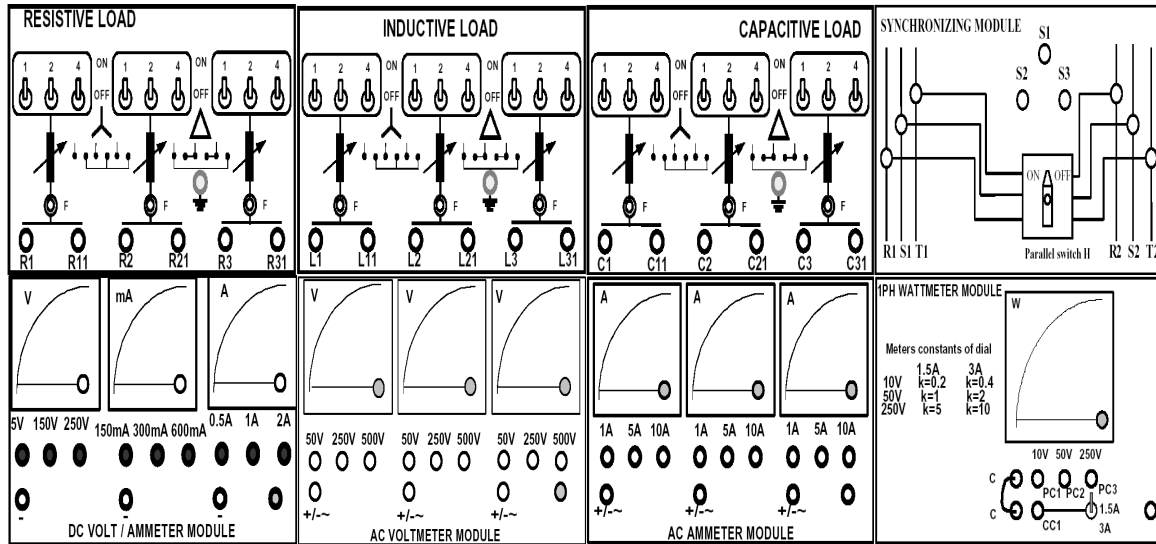

A. No-Load Test:

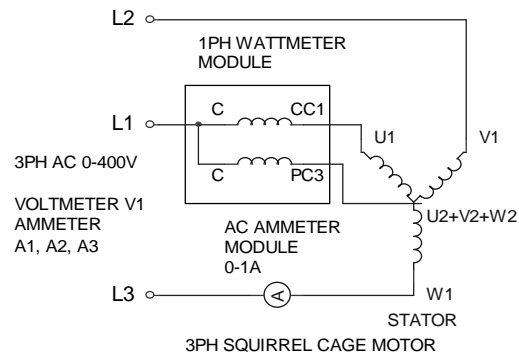

Procedure:

1. Make sure all the switches (I1, I2, I3, I4, I5, I6) on the Power Supply are turned OFF (downwards).
2. Make sure all the variable knobs (K1, K3, K4) are at the min, counter clock wise (CCW) position.
3. Make connections according to the above diagram.
4. Verify the connection by your Lab Teacher
5. Turn ON Switch I1 (upwards).
6. Turn Key K2 Clock Wise Once, the Indicator Lamp L1 becomes Green.
7. Turn knob K1, Apply **400VAC** on the Stator of the Motor.
8. Turn ON Switch I2 (upwards).
9. 3 Phase Squirrel Cage Motor Starts Running
10. Note the readings on AC Voltmeter, Ammeter and Wattmeter Module

B. Blocked Rotor Test

This is also known as locked rotor or short circuit test. This test is used to find:

- (i) Short circuit current with normal voltage applied to the stator.
- (ii) Power factor on short circuit
- (iii) To plot the circle diagram.
- (iv) To find resistance of motor R_{01} and leakage reactance X_{01} (ref. to primary).

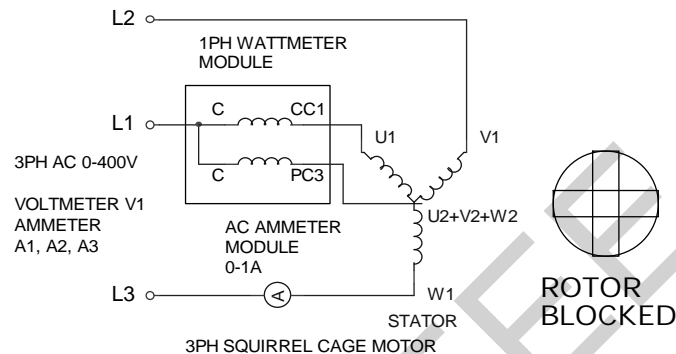

Procedure:

1. Make sure all the switches (I1, I2, I3, I4, I5, I6) on the Power Supply are turned OFF (downwards).
2. Make sure all the variable knobs (K1, K3, K4) are at the min, counter clock wise (CCW) position.
3. Make connections according to the above diagram.
4. Verify the connection by your Lab Teacher
5. Turn ON Switch I1 (upwards).
6. Turn Key K2 Clock Wise Once, the Indicator Lamp L1 becomes Green.
7. ****IMPORTANT:** Make the Stator Voltage **OVAC**
8. ****IMPORTANT:** Note the Rated Stator Current of the 3 Phase Squirrel Cage Motor
9. ****IMPORTANT:** Turn ON Switch I2 (upwards).
10. ****IMPORTANT:** **Block the rotor** and slowly increase the voltage till rated current flows in the stator.
11. Note the readings on AC Voltmeter, Ammeter and Wattmeter Module

Report:

1. What is slip of an induction motor?
2. Draw the approximate equivalent circuit of an induction motor.
3. Explain, "The principle of an induction motor is similar to that of a transformer."

Group No:
Roll no:

Data Sheet

No load test: single phase power = W_0

$$W_0 = \quad I_0 = \quad V_0 =$$

$$G_0 = \frac{W_0}{V_0^2} \quad Y_0 = \frac{I_0}{V_0} \quad \therefore B_0 = \sqrt{Y_0^2 - G_0^2}$$

$$W_0 = V_0 I_0 \cos \Phi_0 \quad \Rightarrow \cos \Phi_0 = \frac{W_0}{V_0 I_0}$$

Blocked rotor test:

$$W_{SC} = \quad I_{SC} = \quad V_{SC} =$$

$$W_{SC} = V_{SC} I_{SC} \cos \Phi_s, \text{ i.e. } \Phi_s =$$

$$W_{SC} = I_{SC}^2 R_{01} \quad Z_{01} = \frac{V_{SC}}{I_{SC}} \quad \therefore X_{01} = \sqrt{Z_{01}^2 - R_{01}^2}$$

Signature of the lab Teacher

Experiment no: **8**
 Experiment name: **Load Characteristics of a 3 Phase Slip Ring Induction Motor.**

Introduction:

Slip ring induction motor is an induction type motor where a three-phase resistance is externally connected to the rotor circuit. Improving its power factor by adding the external resistance increases the starting torque of such a motor. Slip ring motors maintain a slip with respect to the synchronous speed.

For a motor with P poles the synchronous speed, N_s is given by $120f/P$, where f is the supply frequency. Slip, S is defined by $(N_s - N)/N_s$, where N is the speed of rotation of the motor. Measurement of Torque is done by measuring input and output power of the motor.

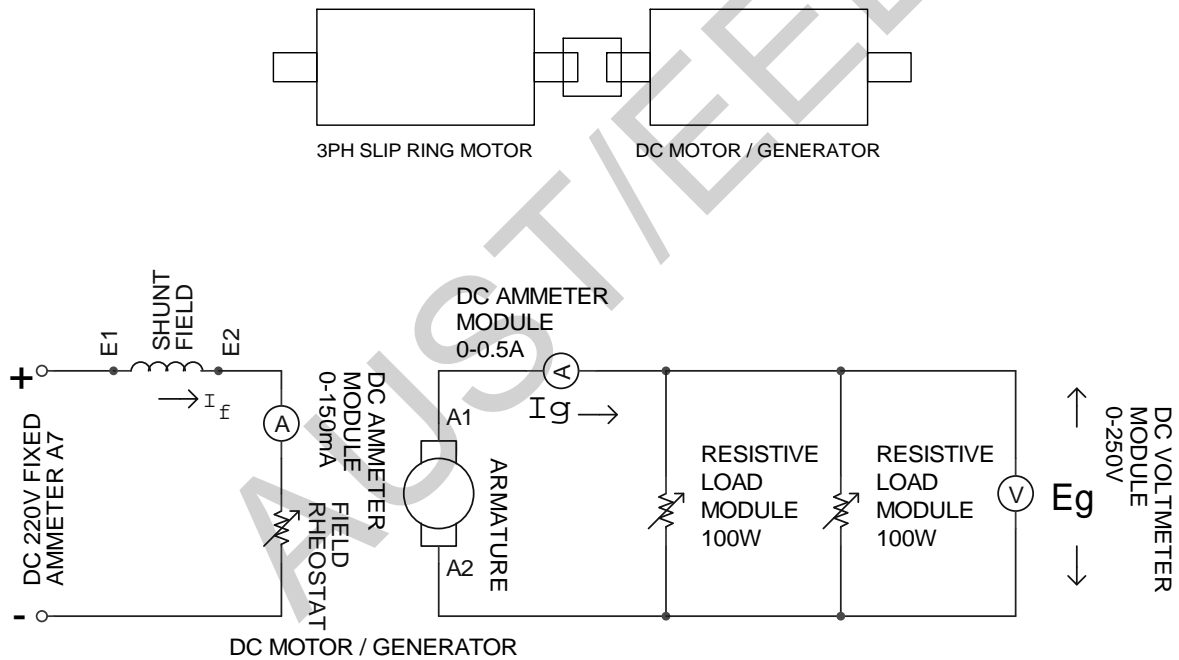

If the electrical power input to the motor is denoted as P_m , mechanical power output of the motor is shown as P_o (which is assumed to be equal to the DC generator's electrical output) and the angular speed is given by ω_m then Torque, $T = P_o / \omega_m$. Input and output powers can be measured as given below:

$P_m = 3W$ where W is the readings of the wattmeter shown in the setup. $P_o = I_g \cdot E_g$ where I_g , E_g are generator current, voltage at generator terminal.

Equipments:

1. Universal Power Supply Module
2. 3 Phase Slip Ring Induction Motor
3. DC Motor / Generator
4. Field Rheostat
5. DC Voltmeter / Ammeter Module
6. 1PH Wattmeter Module
7. Connecting Cables

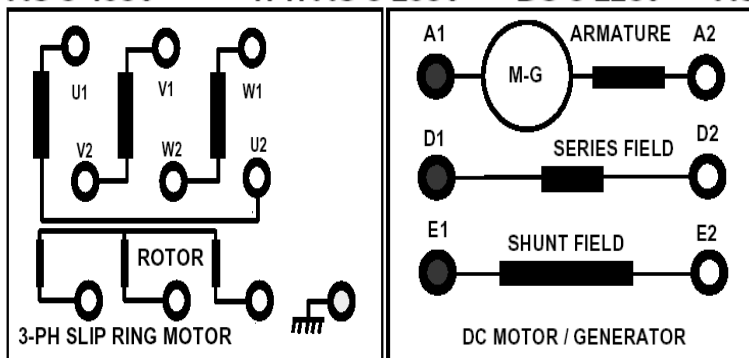
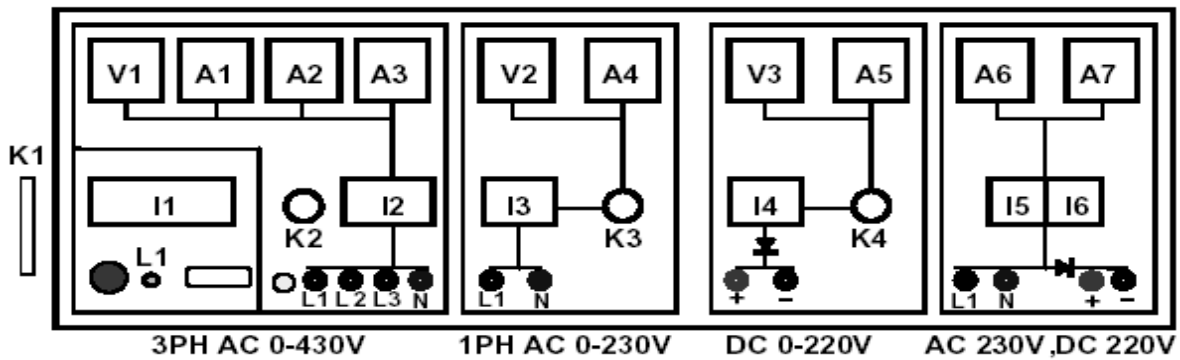
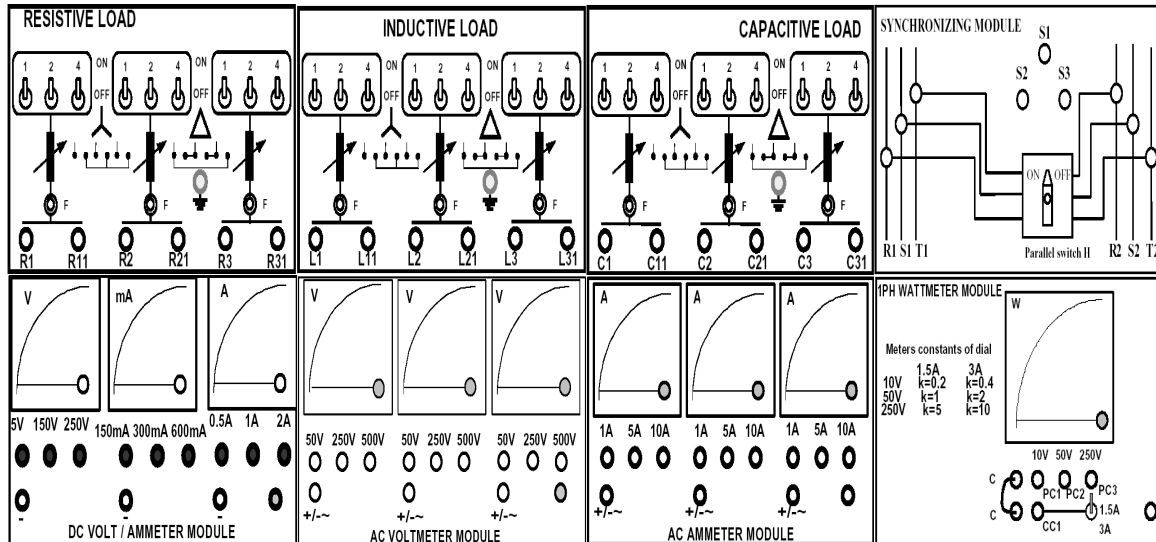

Circuit Diagram:

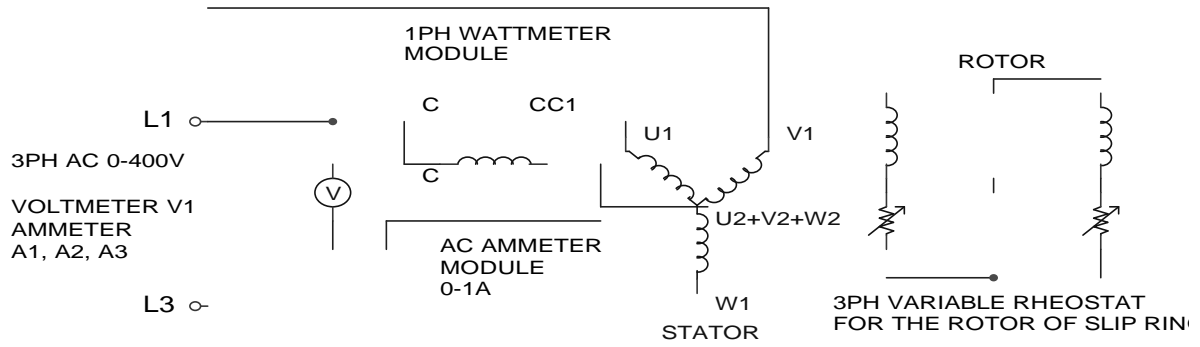

AUST/E/E/E

Group No:
Roll no:

Data Sheet

Power input, $P_M = 3W =$

Power output $= P_O = I_g \cdot E_g =$
Angular speed $W_m = 2 \cdot \pi \cdot N =$

Torque, $T = P_O / W_m =$

Line current, $I =$

Line voltage, $V =$

Power factor, $pf = P_M / \sqrt{3VI} =$

Power input, $P_M = 3W$	Power output $P_O = I_g \cdot E_g$	Angular speed $W_m = 2\pi N$	Torque, $T = P_O / W_m$	Line current, I	Line voltage, V	Power factor, $pf = P_M / \sqrt{3VI}$

Signature of the lab Teacher

Experiment: 9

Experiment name: To study the speed control of a 3 Phase induction motor by using Variable frequency drive (VFD).

Objective:

1. To be familiar with an AC drive (SI8100 inverter).
2. To run a 3 phase squirrel case induction motor in rated frequency (50 Hz) in forward and reverse direction.
3. To change the frequency manually by SI8100 inverter and find the speed of 3 Phase induction motor.

Introduction:

The major effect of change in supply frequency of a 3 phase induction motor is on speed. If the electrical frequency applied to the stator of an induction motor is changed, the speed of rotation of its magnetic field, N_{sync} [$N_{sync} = \frac{120f}{P}$] will change in direct proportion to the change in electrical frequency and the no-load point on the torque-speed characteristic curve will change with it. The synchronous speed of the motor at rated conditions is known as the base speed. By using variable frequency control, it is possible to adjust the speed of the motor either above or below base speed. However, to ensure safe operation, it is important to maintain certain voltage and torque limits on the motor as the frequency is varied. Because at low frequency, the reactance decreases and the motor current may be too high.

Equipment:

1. SI8100 inverter.
2. 3 phase squirrel case induction motor.
3. Tachometer.

Block Diagram:

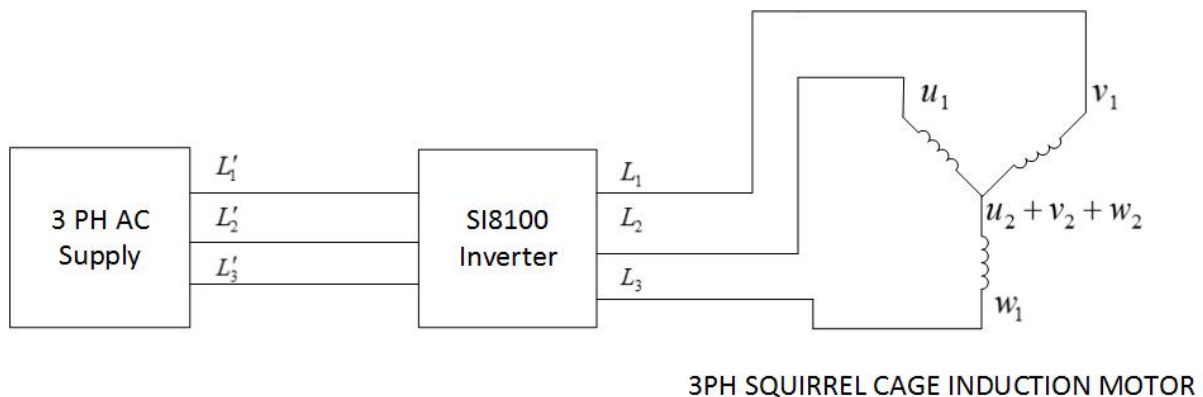

Procedure:

Factory Settings:

It flashes the other settings that the previous user used for a specific purpose. Follow the steps one by one to do factory settings.

1. Press 'PRG' Button.
2. Change the controller [variable knob] and take the upper LCD to 'Y9'.
3. Press 'PRG' Button.
4. Change the controller and take the lower LCD to 'Y00'.
5. Press PRG Button.
6. Change the controller and set the upper LCD to '5'.(Reset system parameter with factory set value)
7. Press 'SET' button.
8. Press 'ESC' button. (until it comes to main menu)

Motor Parameter Settings:

This is done to interface a specific induction motor with the inverter. Here we set the rated frequency, RPM, current etc. of the motor in the converter. Follow the steps one by one to perform motor parameter setting.

1. Press 'PRG' Button.
2. Change the controller and take the upper LCD to 'b8'.
3. Press 'PRG' Button.
4. Change the controller and take the lower LCD to 'b00'.
5. Press 'PRG' Button.
6. Change the controller and set the upper LCD to '50'.(Motor rated frequency)
7. Press 'SET' button
8. Change the controller and take the lower LCD to 'b01'.
9. Press 'PRG' Button.
10. Change the controller and set the upper LCD to '0.9'(Motor rated current)
11. Press 'SET' button.
12. Change the controller and take the lower LCD to 'b02'.
13. Press 'PRG' Button.
14. Change the controller and set the upper LCD to '400'(Motor rated voltage)
15. Press 'SET' button.
16. Change the controller and take the lower LCD to 'b03'.
17. Press 'PRG' Button.
18. Change the controller and set the upper LCD to '1'(Motor pole-pairs)
19. Press 'SET' button.
20. Change the controller and take the lower LCD to 'b04'.
21. Press 'PRG' Button.
22. Change the controller and set the upper LCD to '2840'(Motor rated speed)
23. Press 'SET' button.

24. Press 'ESC' button. (until it comes to main menu)

Showing RPM in upper LCD:

Follow the steps one by one to set the Program to show RPM in upper LCD.

1. Press 'PRG' Button.
2. Change the controller and take the upper LCD to 'A1'.
3. Press 'PRG' Button.
4. Change the controller and take the lower LCD to 'A00'.
5. Press 'PRG' Button.
6. Change the controller and set the upper LCD to '0 . b . 0 . 6 . '
7. Press 'SET' button
8. Press 'ESC' button. (until it comes to main menu)

Experiment A

To run the induction motor in CW direction in 50 Hz frequency. Follow the steps one by one to successfully complete the task.

1. Press 'PRG' Button.
2. Change the controller and take the upper LCD to 'F0'.
3. Press 'PRG' Button.
4. Change the controller and take the lower LCD to 'F45'.
5. Press 'PRG' Button. (in upper LCD the right most seven segment display must flash now)
6. Change the controller and set the upper LCD to '0 . 1 . 0 . 0 . '
7. Press 'SET' button
8. Press 'ESC' button. (until it comes to main menu)
9. Press 'FWD' button. (induction motor rotates in CW direction in 50hz supply frequency, monitor the RPM in the LCD)
10. Press 'stop' button. (To stop the induction motor)

Experiment B

To run the induction motor in CCW direction in 50 Hz frequency. Follow the steps one by one to successfully complete the task.

1. Press 'PRG' Button.
2. Change the controller and take the upper LCD to 'F0'.
3. Press 'PRG' Button.
4. Change the controller and take the lower LCD to 'F45'.
5. Press 'PRG' Button. (in upper LCD the right most seven segment display must flash now)
6. Change the controller and set the upper LCD to '0 . 1 . 0 . 1 . '
7. Press 'SET' button
8. Press 'ESC' button. (until it comes to main menu)

9. Press 'FWD' button. (induction motor rotates in CCW direction in 50hz supply frequency, monitor the RPM in the LCD)
10. Press 'stop' button. (To stop the induction motor.)

Experiment C

To change the frequency manually using the controller and observe the RPM in LCD. Follow the following steps one by one to successfully complete the task.

1. Press 'PRG' Button.
2. Change the controller and take the upper LCD to 'F0'.
3. Press 'PRG' Button.
4. Change the controller and take the lower LCD to 'F02'.
5. Press 'PRG' Button.
6. Change the controller to set the upper LCD to '4' value.
7. Press 'SET' button
8. Press 'ESC' button. (until it comes to main menu)
9. Press 'FWD' button. (Induction motor starts rotating now. Change the controller to change the input frequency of the motor. Observe the RPM on LCD and measure the RPM of rotor with a tachometer for different input frequency)
10. Press 'stop' button. (To stop the induction motor.)

Data Sheet:

Frequency	Rotor speed, N_r	Synchronous speed, N_s	Line to line voltage, V_{L-L}

Report:

1. Plot a curve on graph paper for Rotor speed (N_r) Vs. Frequency.
2. Plot a curve on graph paper for line to line voltage (V_{L-L}) Vs. Frequency.

Reference:

1. Power electronics circuits, devices and applications; Muhammad H. Rashid.
2. SQelectronic Inverter User's Manual.

Experiment no: **10**
Experiment name: **Study of a 1- ϕ induction motor.**

Introduction:

The single-phase induction motor when fed from 1- ϕ supply, its stator winding produces a flux which is alternating i.e. which alternates along one space axis only. An alternating or pulsating flux acting on a stationary squirrel-cage rotor cannot produce rotation. That is why single-phase induction motor is not self-starting. But if the rotor of such machine is given initial start by hand or somewhat other means in either direction, then immediately torque arises and accelerates to its final speed. To make the motor self starting another winding called a starting/auxiliary winding is placed 90 electrical degrees apart from the main or running winding and connected in parallel across the 1- ϕ supply.

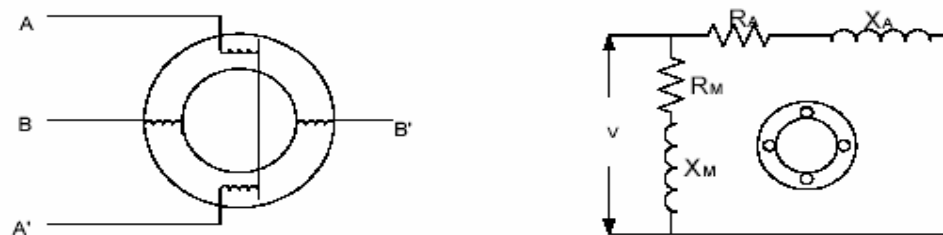

Figure no.1

AA/ = Main winding.
BB/ = Auxiliary winding.

Two theories have been put forward to explain the operation of 1-phase Induction motor. The theories are: 1) Double Revolving Field theory. 2) Cross-field theory.

Equipments:

1. LC meter
2. 1- ϕ Variac
3. Wattmeter
4. AC Voltmeter (0-300 V)
5. AC Ammeter (0-2.5 A)
6. Tachometer
7. Wire for connection

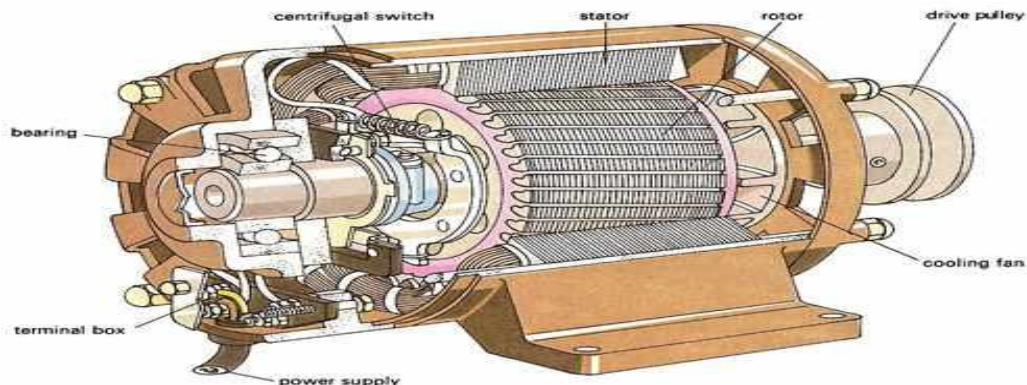

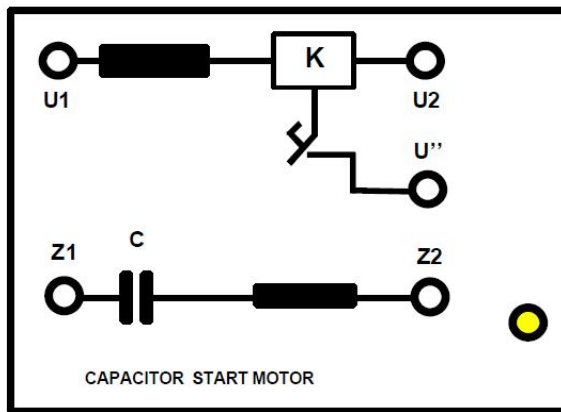
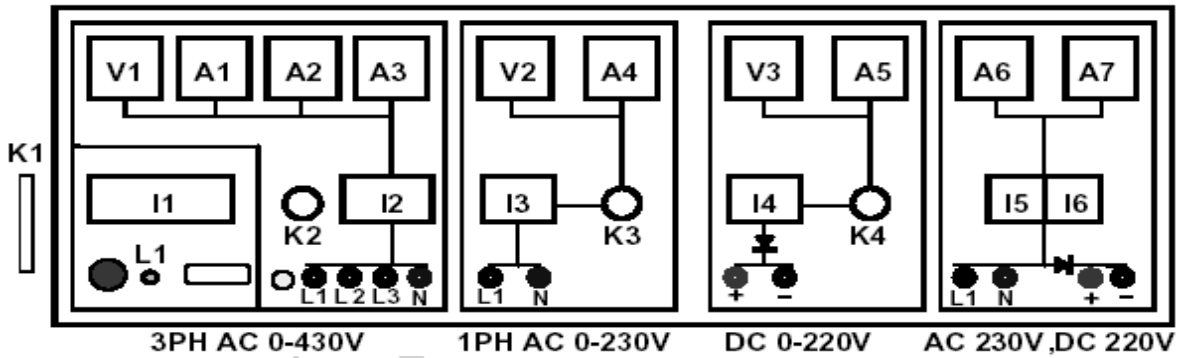
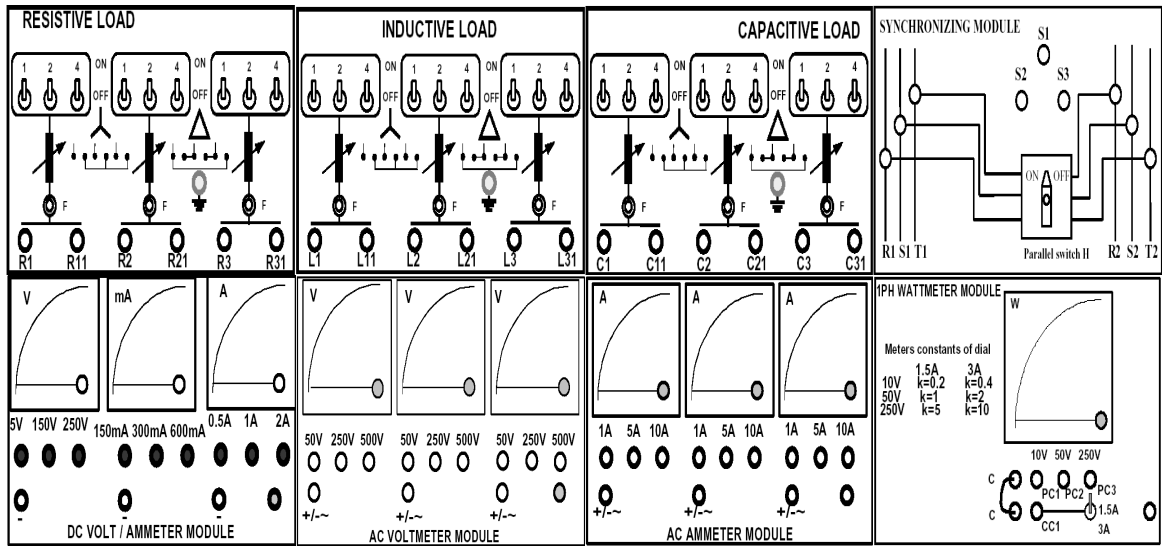

Procedure:

A) To determine the terminals of running and starting winding:

Normally 3 or 4 terminals are available on the motor terminal box. If one terminal of both starting and running windings are internally connected, then 3-terminals are available on the terminal box. The auxiliary winding is designed to have higher resistance/reactance ratio than the main winding so that the current in the auxiliary winding leads the current in the main winding.

1) Take any two-coil terminals and determine its resistance by a sensitive ohm-meter.
 $R_1 = \dots\dots\dots$ ohms.

2) Similarly determine the inductance of the coil by an L-C meter.
 $L_1 = \dots\dots\dots$ henry, $X_{L1} = 2\pi f L_1 = \dots\dots\dots$ ohms.

3) Now take the remaining two coil terminals and measure its resistance and inductance.
 $R_2 = \dots\dots\dots$ ohms, $L_2 = \dots\dots\dots$ henry, $X_{L2} = \dots\dots\dots$ ohms.

Determine R/X_{L1} and R/X_{L2} . From this ratio determine the running winding and starting winding terminals.

B) Running of the motor by the main winding:

1) Connect the terminals of the main winding as per following figure.

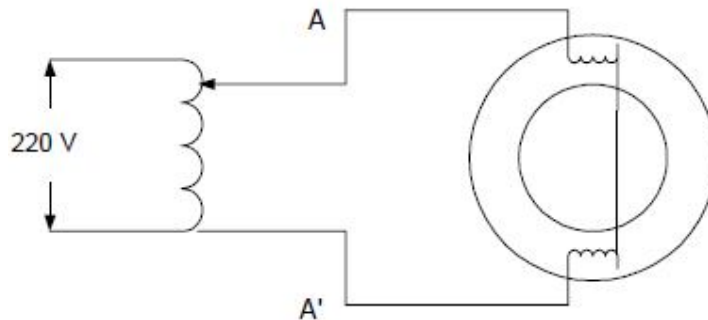

Figure no.2

2) Slowly increase the voltage to 40% and turn the motor in the c.w direction. Does the motor run? Yes No

3) Now reduce the supply to zero, and again increase the voltage gradually to 40% and turn the rotor in the c.c.w direction. Does the motor run? Yes No

C) Running of the motor with the auxiliary winding:

1) Connect the instruments as per following figure-3.

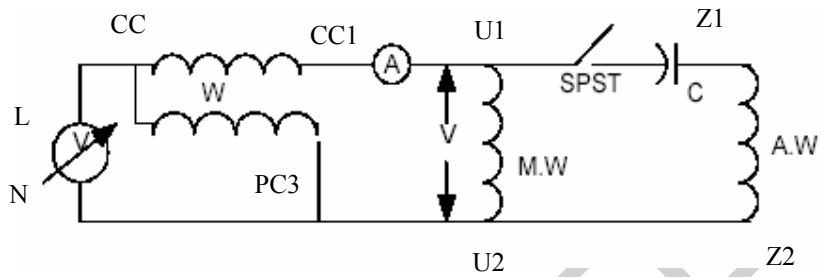

Figure no.3

2) Slowly increase the voltage till the motor run. Then switch-OFF the SPST. Does the motor run? Yes No

Report:

1. In step-B why did the motor rotate in both directions?
2. What is the purpose of capacitor in step-C ? Explain.
3. What have you noticed when you switched-off the SPST in step-C ?
4. Why does the motor continue to run in step-C, when the SPST was switched-off ?

Experiment no: 11

Experiment name: Performance test of a 1- ϕ induction motor.

Introduction:

The aim of the laboratory is to increase understanding of the use of simple 1-phase power systems and current, voltage, power, power factor and mechanical power. Also to develop and understanding of a small 1-phase induction motor. This was achieved by investigating the characteristics of the induction motor at the rated voltage under a range of loads until the motor stalled. It was found that the motor speed under normal operation does not vary much with load. It was also found, by plotting a graph that the efficiency of the motor is at a maximum at its rated load. The specifications on the motor's nameplate were found to be slightly different from the measured values. Speed was found to decrease as the applied torque was increased and the power factor was found to increase as the power output increased. The experiment showed roughly the expected results with a slight variation compared to the motor specifications.

Theory:

Some means must be provided for getting two phases from the standard single-phase power supplied to homes if we need to start and run an AC motor. The process of deriving two phases from one is known as phase-splitting and is usually built into the stator circuit of the AC motor. 2-phase power creates the rotating magnetic field. One method is a special auxiliary winding built into the stator called the start (auxiliary) winding to differentiate it from the actual run (main) winding of the stator. In split-phase AC motors, the start winding is used only for starting the motor and has a high resistance and low inductive reactance. The run winding has low resistance and high reactance. When power is first applied, both windings are energized. Because of their different inductive reactances, the run winding current lags the start winding current, creating a phase difference between the two. Ideally, the phase difference should be 90 degrees; but in practical motors, it is much less. Nevertheless, the windings develop fields that are out of phase, which creates a rotating magnetic field in the stator. This applies torque to the rotor, starting the motor. When the motor gets up to operating speed, the rotor is able to follow the alternations of the magnetic field created by the run winding without the field of the start winding. The start winding is then switched out of the circuit by a mechanical device called a centrifugal switch, because it is operated by the centrifugal force created by the rotor revolutions. The direction of a split-phase rotating field can be reversed by reversing the connections to the start winding. This changes the direction of the initial phase shift, creating a -magnetic field rotating in the opposite direction. The motor speed depends essentially upon the AC power line frequency and the number of poles on the stator.

When power is applied to a split-phase induction motor, both the running (*main*) and the starting (*auxiliary*) windings draw about 4-5 times their normal full load current. This means that the heat loss in these windings is from 16 to 25 times higher than normal. As a result, the starting period must be kept short to prevent overheating of the windings. The high starting currents also produce a proportionally high current in the squirrel-cage rotor, so that the entire motor heats up very quickly during start-up.

The smaller diameter wire employed in the auxiliary winding of split-phase motors is particularly susceptible to overheating and will burn out if it is not disconnected from the power line within 4 to 6 seconds.

The starting current of a split-phase motor is usually 4-5 times normal full-load current. This produces two effects: 1) the motor heats very rapidly during start up; and 2) the high starting current can cause a large line voltage drop so that the starting torque may be seriously reduced. The no-load current is usually 60% to 80% of the full-load current, which is high compared to three-phase motors. Most of the no-load current is used to produce the magnetic field in the motor, and only a small portion is used to overcome the mechanical friction and the copper and iron losses. Because of the large magnetizing current, the power factor of these motors is rarely more than 60%, even at full-load.

The split-phase motor, like all single-phase induction motors, vibrates mechanically at twice the power line frequency. Split-phase motors tend to be much noisier than their 3-phase counterparts, because of the inherent 120 Hz mechanical vibration. This vibration can be reduced by using resilient rubber mounting supports.

The **power output** (in horsepower) of the motor delivered to the load is defined as follows:

$$P_{out, hp} = \frac{1.4 \cdot \omega_{rpm} \cdot T_{Nm}}{10\,000}$$

where ω_{rpm} is the motor speed in revolutions per minute, T_{Nm} is its torque in Newton-meters. Keep in mind that one horsepower equals approximately to 746 W. The **reactive power**_[var] can be computed as:

$$Q = \sqrt{S^2 - P^2}$$

where S is the apparent power [VA], P is the real power [W] consumed by the motor. The **efficiency of the motor** is:

$$efficiency = \frac{P_{out, W}}{P} \cdot 100\%$$

where $P_{out, W}$ is the output power delivered to the load in Watts. The **motor losses**, therefore, are estimated as:

$$Losses = P - P_{out, W}$$

Equipments:

1. 1- ϕ Variac
2. Wattmeter
3. AC Voltmeter (0-300 V)
4. AC Ammeter (0-2.5 A)
5. Tachometer
6. Wire for Connection

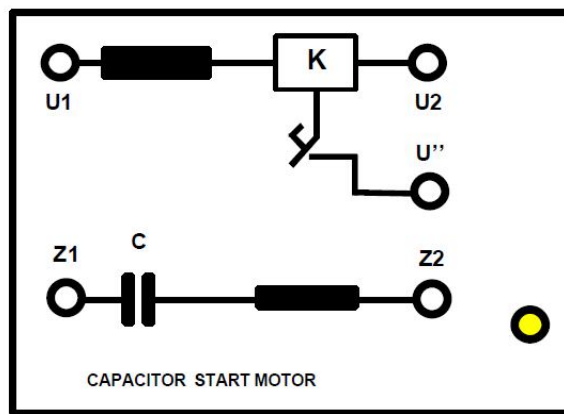
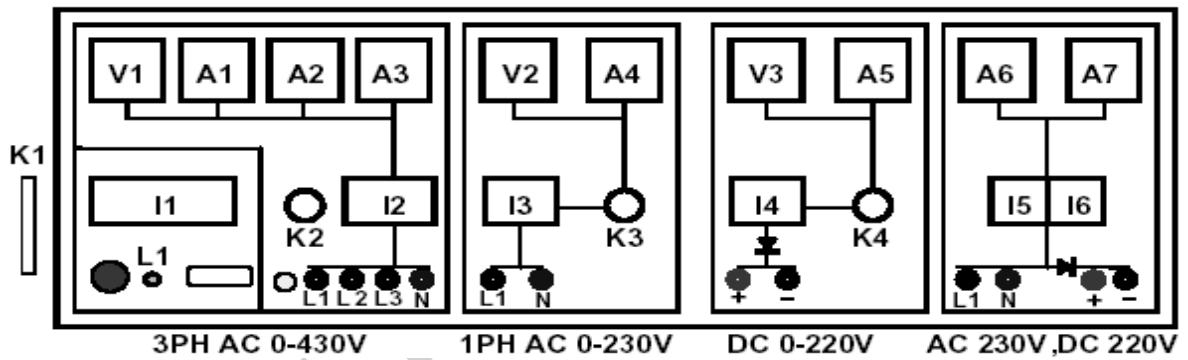
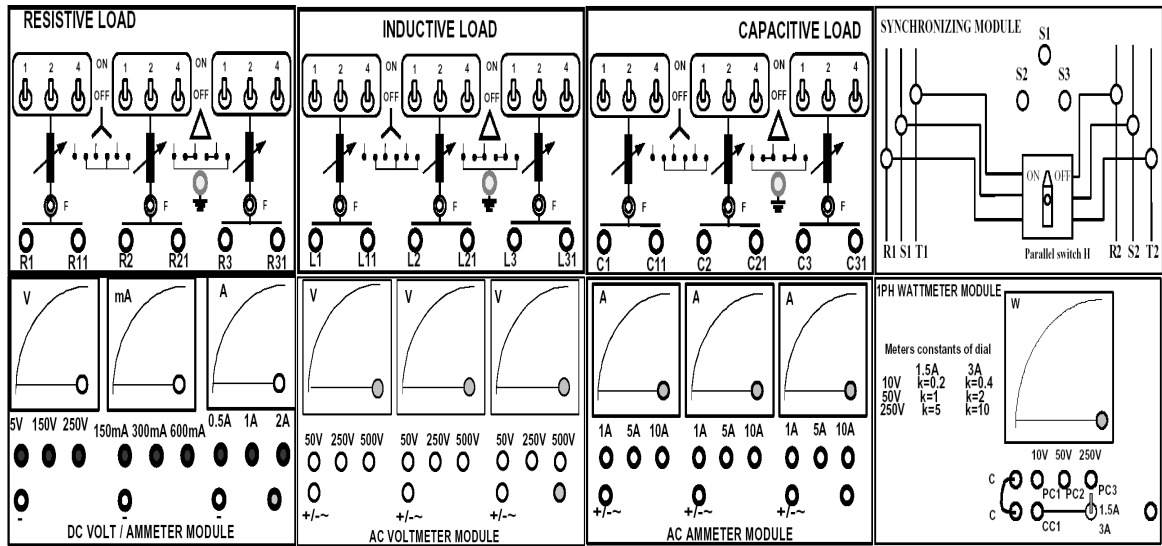

Procedure:

Performance test:

- 1) Connect the instruments as per following figure-1.

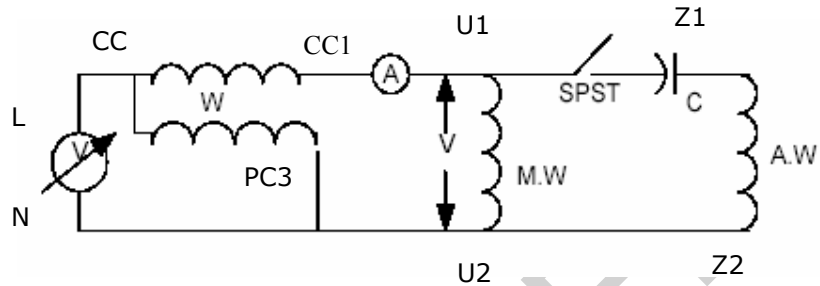

Figure no.1

- 2) Reduce the supply to zero. Switch-ON the SPST. Increase the voltage gradually and fill-up the **table-1**.
- 3) Locked the motor and gradually increase the voltage till the rated current flows through the motor. Write down the block rotor test data on data sheet.

Report:

1. Do you notice any appreciable change in power with the change of speed ? Explain in brief. transformer draw any current when its secondary is open? If yes, then why?

Group No: Roll no:

Data Sheet

% Input Voltage	W Watts	V Volts	A Ampere	N r.p.m	%change in power

Table-1

Block rotor test:

W=.....

A=.....

V=.....

Signature of the Lab teacher:

Equipments:

1. Universal Power Supply Module
2. 3 Phase Slip Ring Induction Motor
3. DC Motor / Generator
4. Field Rheostat
5. DC Voltmeter / Ammeter Module
6. 1PH Wattmeter Module
7. Connecting Cables

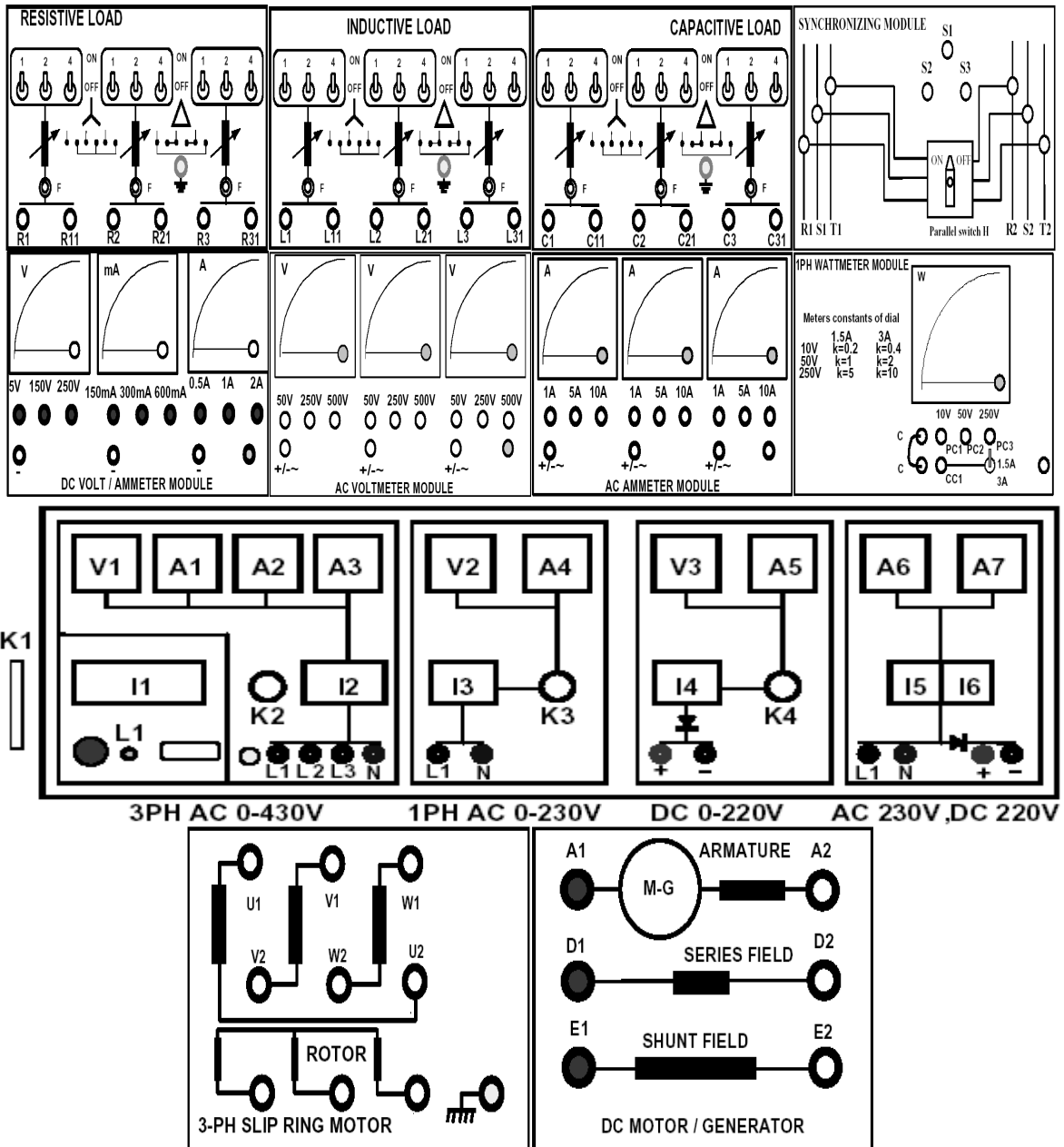

Circuit Diagram:

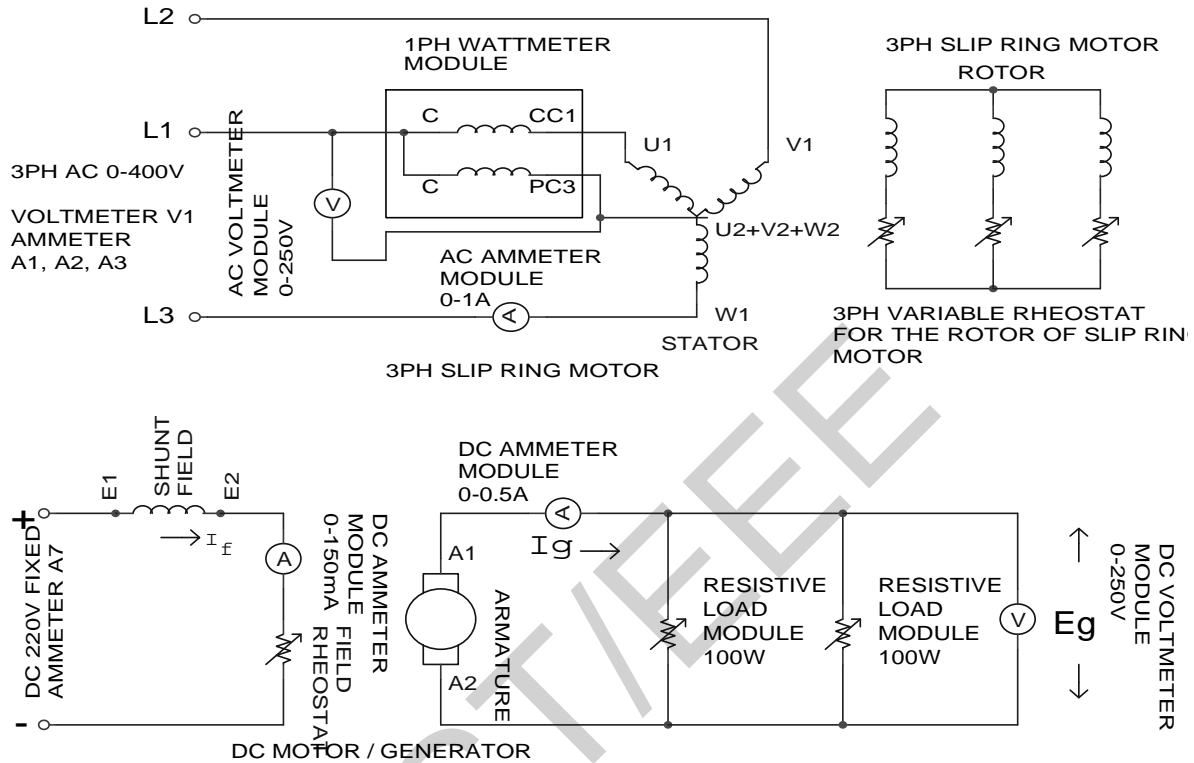

Procedure:

1. Make sure all the switches (I1, I2, I3, I4, I5, I6) on the Power Supply are turned OFF (downwards).
2. Make sure all the variable knobs (K1, K3, K4) are at the min, counter clock wise (CCW) position.
3. Make connections according to the above diagram.
4. Verify the connection by your Lab Teacher
5. Turn ON Switch I1 (upwards).
6. Turn Key K2 Clock Wise Once, the Indicator Lamp L1 becomes Green.
7. ****IMPORTANT: KEEP Switch I6 OFF (downwards).**
8. Turn knob K1, Apply **400VAC** on the Stator of the Motor.
9. Turn ON Switch I2 (upwards).
10. 3 Phase Slip Ring Motor Starts Running
11. Turn ON Switch I6 (upwards).
12. Vary the field rheostat of the DC Generator, make terminal voltage **200VDC**
13. Now vary the torque, and fill the table

Report:

1. Plot power factor vs. torque for both motors.
2. Discuss various characteristics of slip ring induction motor

Group No:
Roll no:

Data Sheet

Power input, $P_M = 3W =$

Power output $= P_O = I_g \cdot E_g =$
Angular speed $\omega_m = 2 \cdot \pi \cdot N =$

Torque, $T = P_O / \omega_m =$
Line current, $I =$
Line voltage, $V =$
Power factor, $pf = P_M / \sqrt{3}VI =$

Power input, $P_M = 3W$	Power output $P_O = I_g \cdot E_g$	Angular speed $\omega_m = 2\pi N$	Torque, $T = P_O / \omega_m$	Line current, I	Line voltage, V	Power factor, $pf = P_M / \sqrt{3}VI$

Signature of the lab Teacher