



CE 442 GEOTECHNICAL ENGINEERING SESSIONAL II



Department of Civil Engineering
Ahsanullah University of Science and Technology

December, 2017

Preface

The substructure or foundation is the part of a structure that is usually placed below the surface of the ground to transmit the load from the superstructure to the underlying soil or rock. It is a very important part of all the structures. Someone has been differentiated between substructure and foundation. They define the substructure as the structure which is below ground level and consists of a basement as well as foundation. This lab manual explains how load is transferred from superstructure to foundation, what should be the capacity of the sub-soil to bear the load for different types of foundations, different types of settlements as well as differential settlement and their calculations and how to design different foundations with reinforcement design. A typical building plan and a soil test report are supplied for each group of students. A plan and a soil report are also shown at the end of the manual as an exercise. This Lab manual was prepared with the help of some geotechnical engineering books and some other lecture notes.

The lab manual was first prepared in 2013. The pile portion was slightly added in 2014 by Mr. Mudasser Siraj Rafi, Ex. Lecturer of Dept. of CE. In 2017 the pile portion was fully modified and the settlement of Mat foundation was prepared and added to the manual by Mr. Sabuj Chowdhury, Lecturer of Dept. of CE. The manual was checked by Prof. Dr. Md. Abul Bashar in December 2017. Ms. Tanzila Tabassum, Lecturer of Dept. of CE made the corrections according to suggestion of Prof. Dr. Md. Abul Bashar.

A S M Fahad Hossain
Department of Civil Engineering
Ahsanullah University of Science and Technology

INDEX

SL No.	Topics	Page no.
1	Chapter 1: Building Foundation	4
2	Chapter 2: Calculation of Superimposed Load	10
3	Chapter 3: Bearing Capacity of Shallow Foundation	15
4	Chapter 4: Bearing capacity of Pile Foundation	34
5	Chapter 5: Bearing capacity of Mat foundation	45
6	Chapter 6: Soil Settlement Shallow Foundation Pile Foundation Mat Foundation	48
7	Chapter 7: Structural Design Isolated Column Footing Combined and Strip Footing Mat Foundation	72
8	Appendix	87
	Appendix-1: Work To Do	
	Appendix-2: Soil Test Reports	
	Appendix-3: Geo-Properties and Correlations	
	Appendix-4: Lab report format	
	Appendix-5: Lab Instructions	

CHAPTER 1

BUILDING FOUNDATION



Definition

The substructure or foundation is the part of a structure that is usually placed below the surface of the ground to transmit the load from the superstructure to the underlying soil or rock. There is a difference between foundation and footing. In simple words, foundation means legs and footing means the foot of the leg.

In addition, foundation also serves some other functions, such as:

- Prevent settlement (including differential settlement) of a structure.
- Prevent possible movement of structure due to periodic shrinkage and swelling of subsoil.
- Allow building over water or water-logged ground.
- Resist uplifting or overturning forces due to wind.
- Resist lateral forces due to soil movement.
- Underpin (support) existing or unstable structures.

Factors to be Considered in Selecting Foundation Type

- Subsurface conditions
- Groundwater conditions
- Column loads and spacing, basements
- Site constraints
 - noise
 - vibrations
 - proximity to existing improvements, slope, channel
- Economics

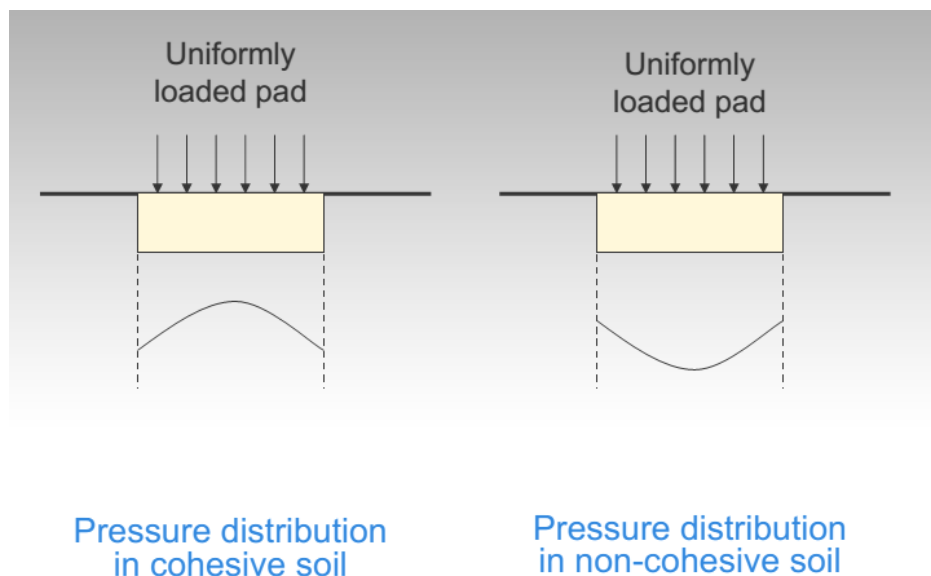

Figure 1.1: Loading condition of foundation (pressure distribution in different soil)

General Foundation Types

Types of Foundations:

Foundations can be broadly classified into two types:

- (i) Shallow foundations
- (ii) Deep foundations

Shallow Foundation:

- (a) When depth of foundation, $D_f \leq B$ (B = width of foundation) → Shallow footing
- (b) When $B < D_f < 15B$ → Deep footing

The combined name of (a) and (b) is called Shallow foundations

Deep Foundation

- (c) When $D_f > 15B$ → Deep foundations

Types of Shallow Footings/Foundations:

From the point of view of design, shallow footings/foundations are classified into following types:

1. Spread or Isolated or Individual column footing
 - (i) Square or Rectangular footing of uniform thickness
 - (ii) Sloped square/rectangular footing
 - (iii) Stepped/Pedestal square/rectangular footing
2. Combined footing (rectangular/trapezoidal as well as slab type / slab-beam type)
3. Strip or Continuous footing (wall footing)
4. Strap or Cantilever footing
5. Mat or Raft foundation

Types of Deep Foundations:

1. Pile foundations
2. Pier foundations
3. Well foundations
4. Caissons, etc.

Someone has been mentioned that if depth of foundation is more than about 3m, then the foundation is termed as deep foundation.

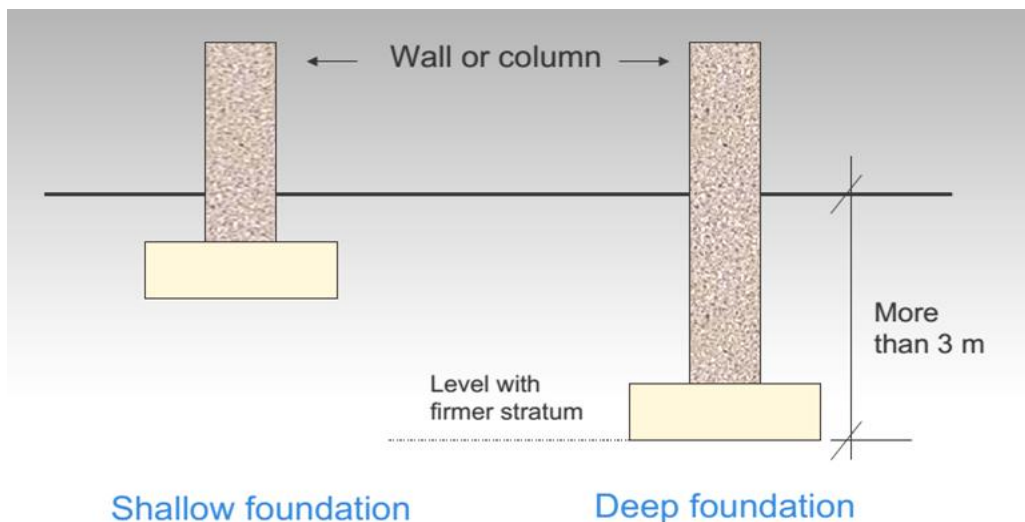

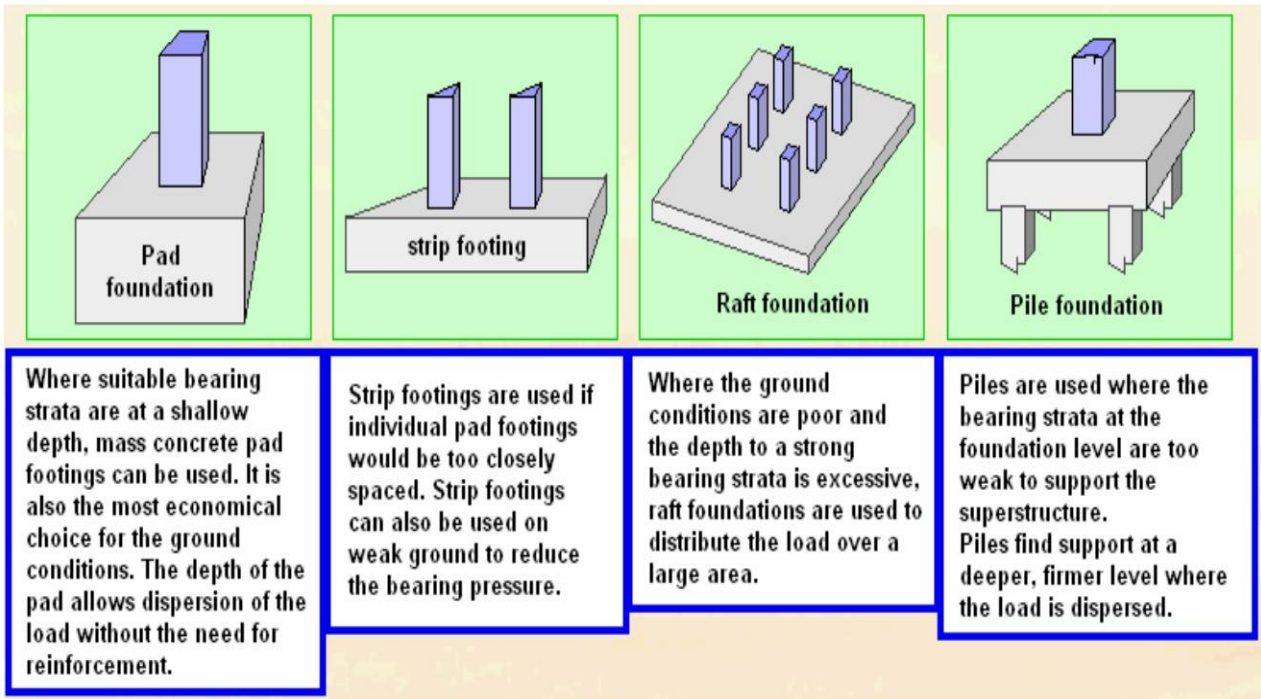
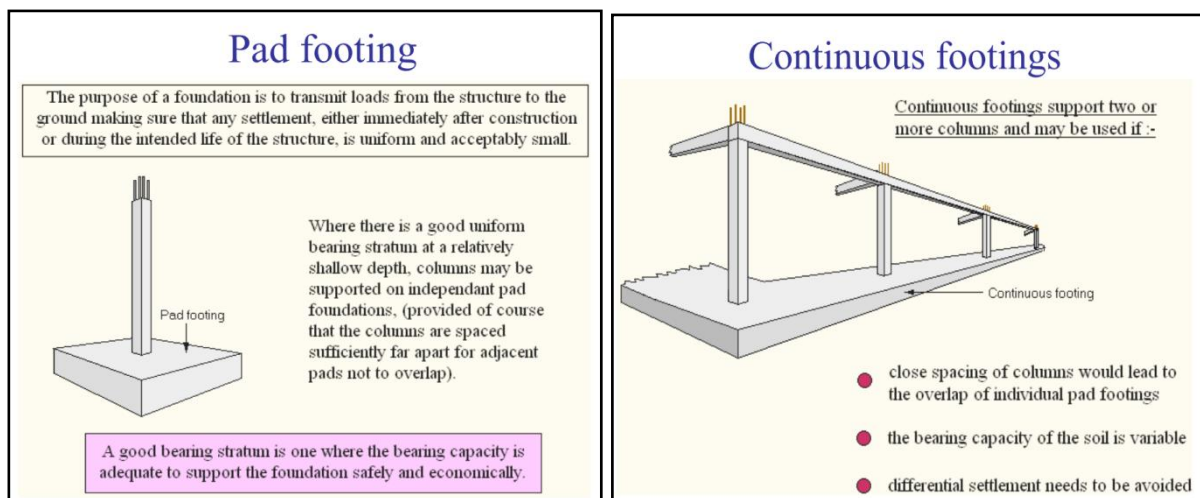

Figure 1.2: Shallow and Deep Foundation



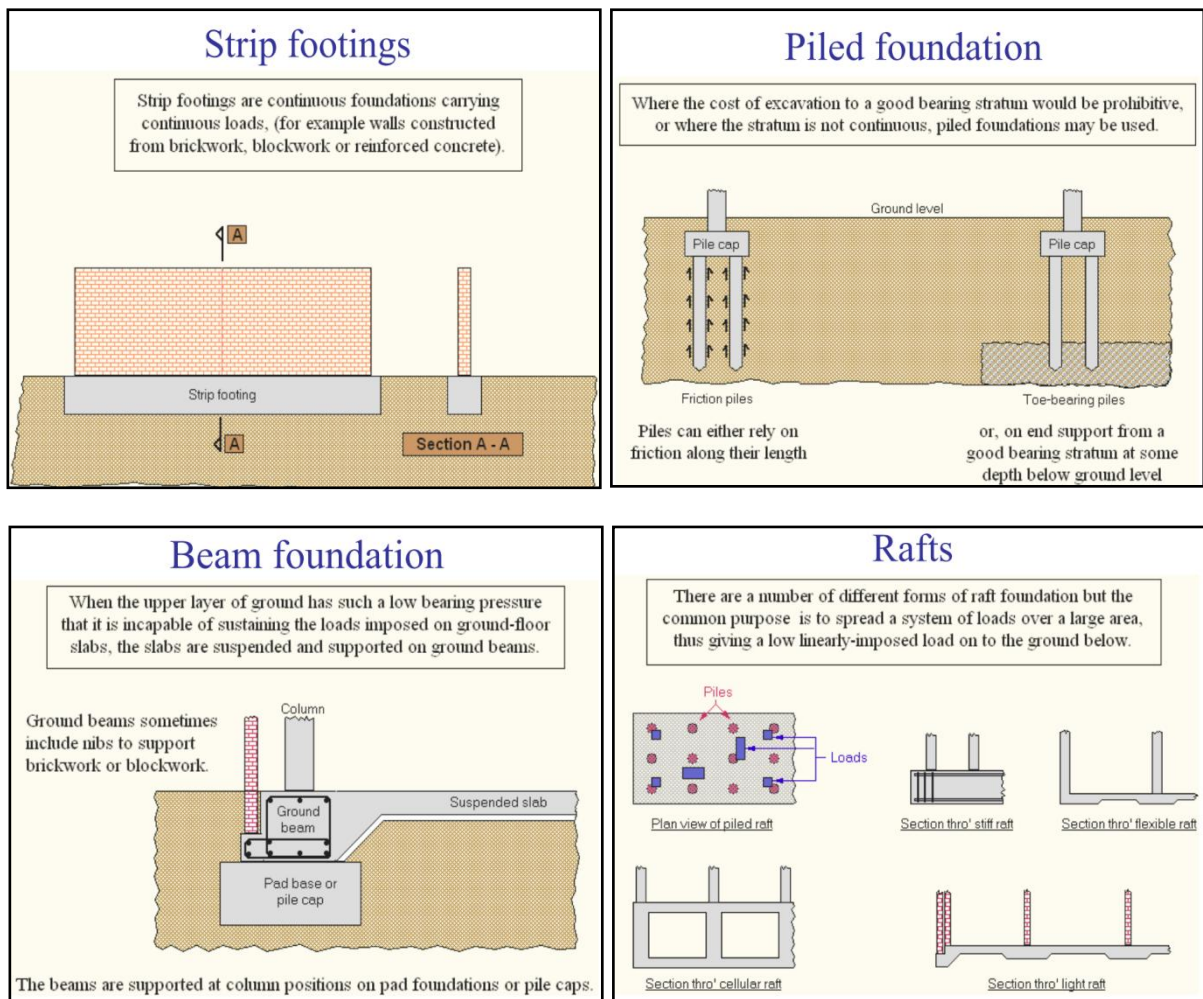

Figure 1.3: Shallow Foundation/Footing

This type of foundation usually refers to those being rested on stratum with adequate bearing capacity and laid less than 3m below ground level. Common examples include pad, strip or raft foundations.

The selection of the appropriate type of shallow foundations normally depends on the magnitude and disposition of the structural loads and the bearing capacity of subsoil. A combination of two or three types of shallow foundation in one single structure is not uncommon.

Raft Foundation

Raft foundation is mainly a large slab type or slab-beam type, designed to seat and support the whole or a large part of a structure.

A raft is usually used when subsoil is weak, or columns are closely located and with variable loadings. It also serves as a transfer slab to combine and tie up all the vertical loading elements to the slab type foundation. By doing so, differential settlement can be avoided.

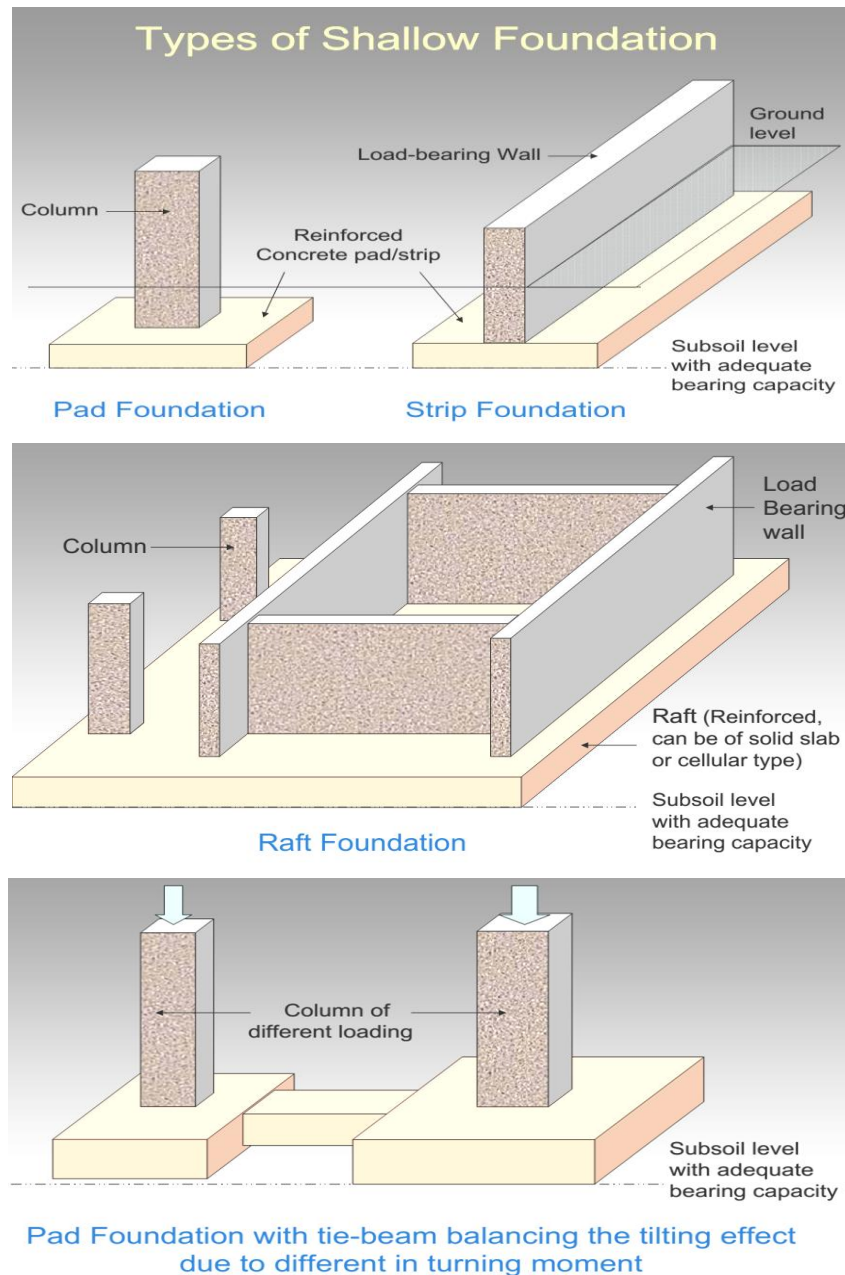

Figure 1.4: Deep Foundation

Pile Foundation

Pile foundation is a form of foundation using piles to transfer the loads of a superstructure down to a firm soil stratum with sufficient load bearing capacity.

Materials for the piles can be of:

- Timber
- precast concrete (sometimes also prestressed)
- In-situ reinforced concrete
- steel piles in ‘H’ or circular section

Load from a superstructure is transmitted to the subsoil either by end bearing or skin friction or both that depends on soil conditions.

End Bearing or Point Bearing Piles: When piles are driven on, or into, a hard strata or soft rock of

adequate bearing capacity through soft stratum to transfer superimposed load, then the piles are known as end bearing or point bearing piles. Here pile tip is well seated on the rock or hard stratum.

Skin friction Piles: A skin friction pile in clay is supported by adhesion between the pile and the soil or load is supported by the frictional resistance so created between the contact surface of the pile and the embracing soil.

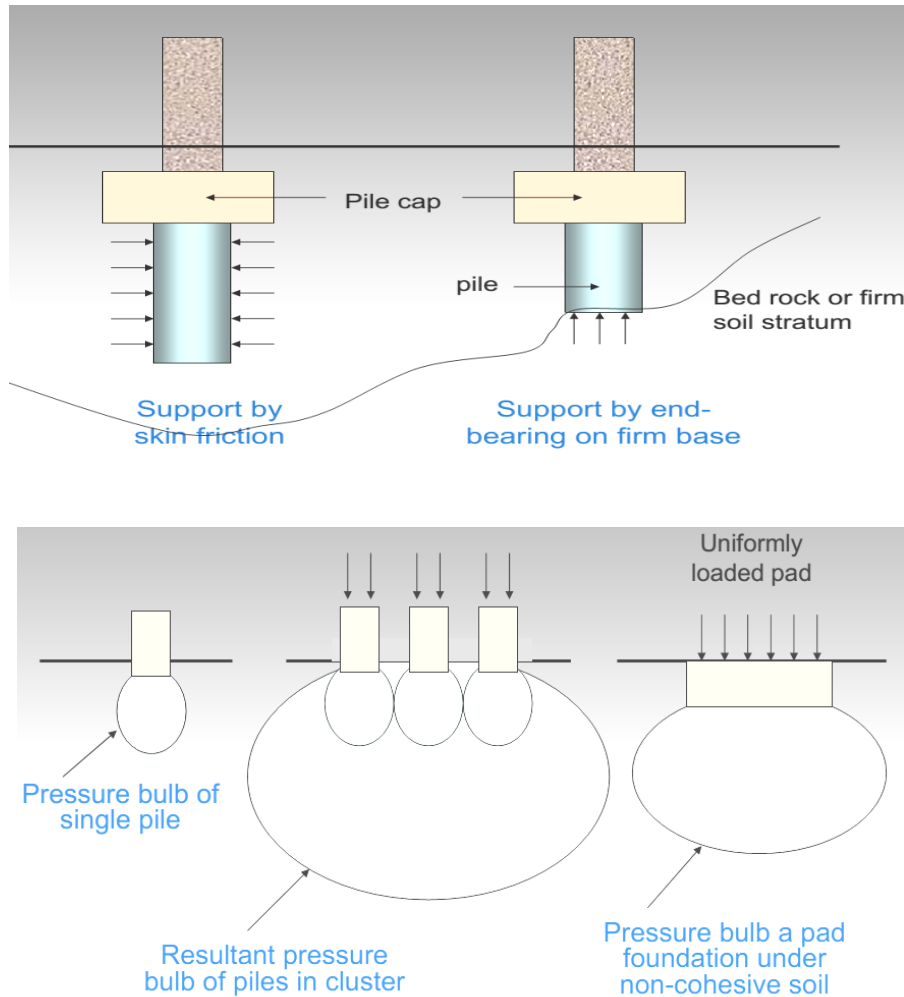

Figure 1.5: Loading condition of foundation (pressure bulb)

CHAPTER 2 CALCULATION OF SUPERIMPOSED LOAD



Steps to calculate the load on slab, beam, column and foundation:

1. First consider the thickness of slab from the suitable approximate formula for one-way slab or two-way slab.
2. Then determine the total load on slab per unit area considering live load, floor finish load, partition wall load in addition to self weight of slab.
3. Distribute the slab load on four adjacent beam of the slab and to find out the total load on each beam, add the load from slab on each side of beam in addition to partition wall on the beam and extra self weight of beam (i.e., load for the depth of beam which is total depth of beam minus slab thickness).
4. Each beam transfers its load to the connecting columns. Determine the total superimposed load on each column from the load of connecting beams with it in addition to self weight of column.
5. Now the column will transfer the superimposed load to foundation and then the foundation will transfer the total load to the soil including self weight of foundation.
6. We have to know the bearing capacity of underlying soil of the foundation from soil test report or from plate load test or pile load test which is suitable for the proposed structure.
7. Then area of the foundation is determined from dividing the total superimposed load on the column in addition to self weight of the footing/foundation by allowable bearing capacity of underlying soil. Initially self weight of the foundation may be assumed as about 8 to 10% of the superimposed load.
8. To calculate area of the footing unfactored load is under consideration. If wind load or earthquake load is considered then allowable bearing capacity of soil is increased by 33% to calculate the required area of the footing.

Discussion on the calculation of load on beam from rectangular or square slab:

The load from slab panel will be transferred to the beam in two ways:

- (a) For the rectangular slab it will be transferred by two triangular and two trapezoidal panels. For the square slab panel it will transfer loads by four triangular panels. This system is called yield line analysis. The panels are shown in figure below. The yield line will spread at 45 degree from each column. The distribution of slab load on short span, S and long span, L can also be determined by using the following formulae:

- (b) According to ACI Code:

Load transferred on the short span (length = S) from slab, $W_s = wS^2/4$ (i)

Load transferred on the long span (length = L) from slab, $W_L = wS^2/4 \left(\frac{2-m}{m} \right)$ (ii)

where, w = total load for the slab per sft. and $m = \frac{S}{L}$

Here, for simply supported slab, S = c/c distance between supports or clear distance + 2t (t = slab thickness), whichever is the smaller.

For continuous slab, S = c/c distance should be used.

Considering the rule (a) the following plan includes slab-beam with load distribution lines:

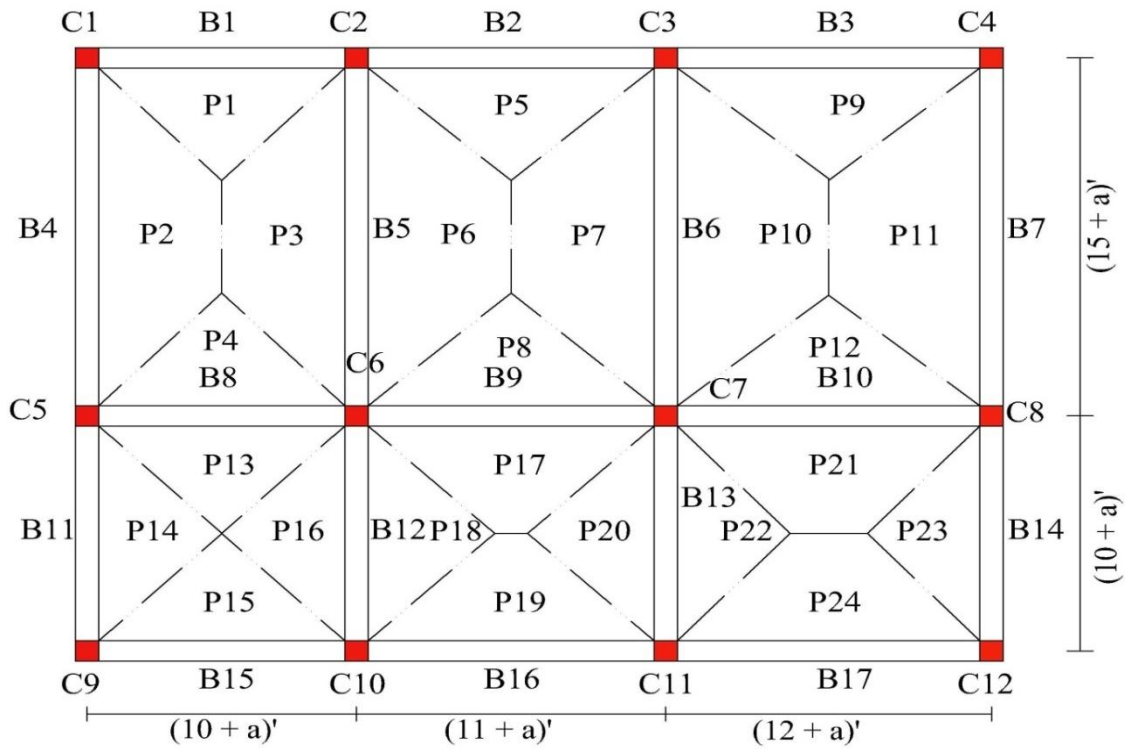

Problem 2.1: There is a column-beam layout plan for a 6 storied residential building given below. Calculate the superimposed load of each column.

- Use:
- Slab thickness : 6"
 - All Beams : 12" X 18"
 - All Columns : 12" X 12"
 - Floor Finish (FF) : 25psf
 - Partition Wall (PW) : 40psf
 - Live load (LL) : 60psf
 - Factor, a (ft) : Roll x 0.2

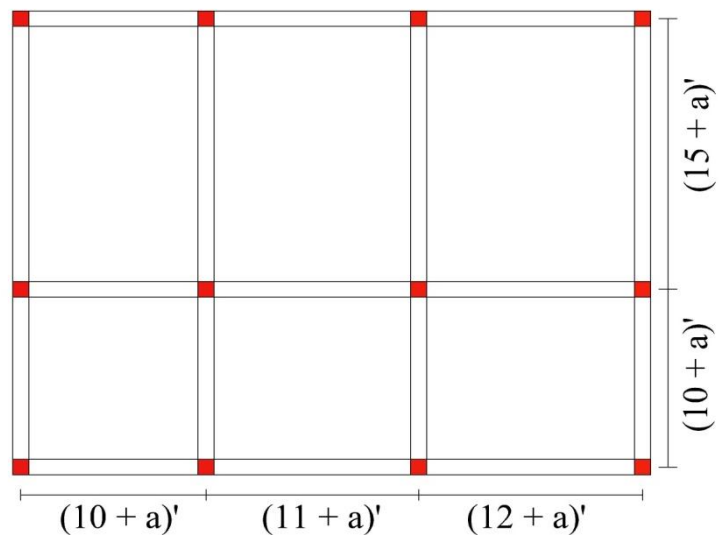

Solution:

Step 1: Calculation of self weight of members

$$\begin{aligned}\text{Self weight of Slab (Th. 6")} &= \frac{6}{12} \times 150 = 75 \text{psf} \\ \text{Self weight of Beam (12"x18")} &= \frac{12 \times 12}{144} \times 150 = 150 \text{plf} \\ \text{Self weight of Column (12"x12")} &= \frac{12 \times 12}{144} \times 150 = 150 \text{plf}\end{aligned}$$

Step 2: Load on Slab:

UDL, w for Slab = Slab wt. of slab + Floor finish + Partition wall + Live Load =
75+25+40+60+ = 200psf

Slab load on triangular panel:

Panel No.	Base (b)	Height (h)	Area = 0.5x bh	Total load = w x 0.5bh
S1/S2, etc				

Slab load on trapezoidal panel:

Panel No.	Short length, b_1	Long Length, c_1	Height, h	Area = $(b_1+c_1)/2 \times h$	Total load = area x w
S1/S2, etc					

Short and long lengths are the parallel sides of trapezoidal.

Step 3: Load on beam:

Beam No.	Length L	Self weight = L x weight per ft beam	Load contributing Slab panel	Load from slab	Load from Over headed water tank	Load from Stair	Total load
B1/ B2, etc							

Step 4: Load on column:

Column No.	Load from column connecting beams	Load from beam (half load)	Self weight of column = 150 x storey height	Total load for each story	Total Load for each storey x No. of storey
C1/C2, etc					

* All Tables should be completed using Excel.

CHAPTER 3

BEARING CAPACITY OF SHALLOW FOOTING

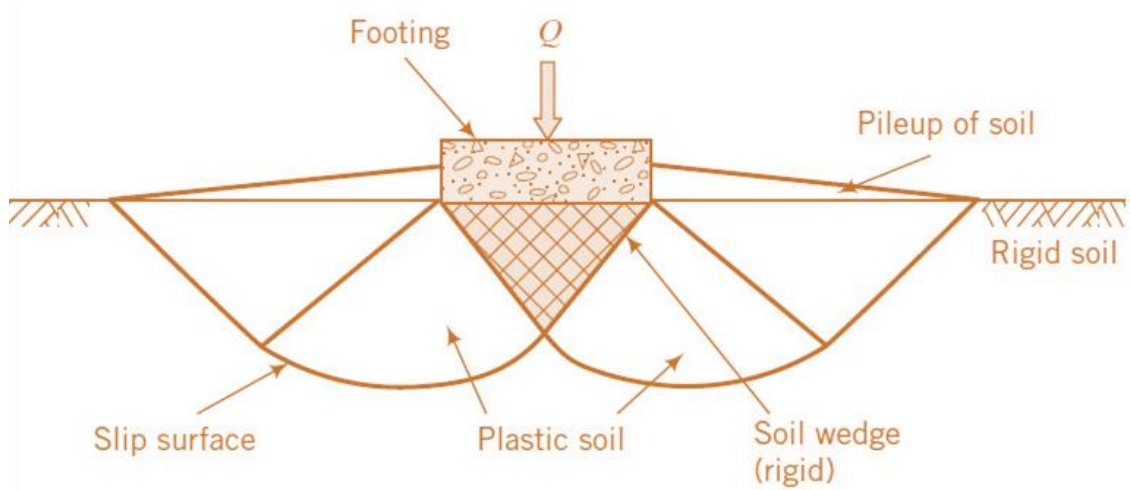

All civil engineering structures impose a loading on the underlying soil (or rock). The lowest part of the structure, usually lying below the ground level, which transmits the load to the supporting soil/rock strata, is known as foundation. The ability of the underlying soil to bear the load of the foundation without overstressing the soil in terms of either shear failure or excessive settlement failure is termed as bearing capacity of soil. This is often termed as bearing capacity of foundation.

The bearing capacity of a soil depends mainly on the types of foundation encountered by the soil. Foundations of structures are basically of two types; **shallow and deep**. The classification indicates the depth of foundation installation and the depth of the soil strata providing most of the support. A number of definitions are relevant in the context of types of foundation and bearing capacity.

Basic Definitions

Shallow Foundation: Shallow foundation is one that is placed on a firm soil at shallow depth below ground level and beneath the lowest part of the superstructure. e.g. spread footing or simply footing, mat or raft etc. The most useful definition of a shallow foundation refers to the founding depth being less than the breadth of the foundation. However, for wide foundation this is not acceptable. It is sensible to limit the term **shallow to mean less than 3 m or less than the breadth of the foundation footing.**

Deep Foundation: Deep foundation is one that transmits the load of the structure considerably at a greater depth below the lowest part of the superstructure. e.g. pile, pier, caissons etc.

Foundation Soil or Bed: The soil to which loads are transmitted from the base of the structure.

Footing: An enlarged base of the structure to distribute the column or wall load to ground at a compatible strength and deformation characteristics of foundation soil.

Mat or Raft: This is characterized by the feature of framing columns or walls into the footing in two directions. Any number of columns can be accommodated with as low as four columns.

Bearing Capacity: This is a general term used to describe, the load carrying capacity of a foundation soil that enables to bear and transmit loads from a structure.

Ultimate Bearing Capacity: Maximum pressure that a foundation soil can withstand without the occurrence of shear failure of the foundation.

Gross Bearing Capacity: The bearing capacity inclusive of the pressure exerted by the weight of the soil standing on the foundation (called the surcharge pressure) is known as gross bearing capacity.

Net bearing capacity: Gross bearing capacity minus the original overburden pressure or surcharge pressure at the foundation level; obviously, this will be the same as the gross capacity when the depth of foundation is zero.

Safe bearing capacity: Net ultimate bearing capacity divided by a factor of safety. **The factor of safety in foundation may range from 2 to 4**, depending upon the importance of structure, and the soil profile at the site. The factor of safety should be applied to the net ultimate bearing capacity, and the surcharge pressure should then be added to get the safe bearing capacity.

It is thus the maximum intensity of loading that can be transmitted to the soil without the risk of shear failure, irrespective of the settlement that may occur.

Allowable bearing capacity/pressure: The maximum allowable net loading intensity on the soil at which the soil neither fails in shear nor undergoes excessive or intolerable settlement detrimental to

the structure. The conventional design of a foundation is based on the concept of bearing capacity or allowable bearing pressure.

Criteria for the Determination of Bearing Capacity

The criteria for the determination of bearing capacity of a foundation are based on the requirements for the stability of the foundation. These are stated as follows:

- ❖ **Shear failure of a foundation soil or bearing capacity failure:** This is associated with plastic flow of the soil material beneath the foundation, and lateral expulsion of the soil from underneath the footing.
- ❖ **The probable settlements, differential as well as total:** The settlement of the foundation must be limited to safe, tolerable and acceptable magnitude.

Factors Affecting Bearing Capacity

Bearing capacity is governed by a number of factors. The following are the some of the important factors that affect the bearing capacity.

- **Nature of soil and its physical and engineering properties**
- **Nature of the foundation and other details such as the size, shape, depth at which the foundation is located and rigidity of the structure**
- **Total and differential settlement that the structure can withstand without functional failure**
- **Location of ground water table relative to the level of foundation**
- **Initial stresses, if any.**

In view of the wide variety of factors that affect the bearing capacity, a systematic study of the factors involved is necessary for proper understanding.

Bearing Capacity of Shallow Foundations

The following methods are available for the determination of bearing capacity of a shallow foundation:

- **Bearing capacity tables in various building codes**
- **Analytical methods**
- **Plate bearing tests**
- **Penetration tests**
- **Model tests and prototype tests**
- **Laboratory tests**

Bearing capacity tables have been evolved by certain agencies and incorporated in building codes. They are mostly based on past experience and some investigations.

Various analytical approaches are available. Usually they are expressed in terms of equations commonly known as bearing capacity equation. The prominent of these are given by:

- | | |
|---------------------|-------------------|
| ➤ Rankine (1857) | ➤ Terzaghi (1943) |
| ➤ Pauker (1889) | ➤ Meyerhof (1951) |
| ➤ Bell (1915) | ➤ Skempton (1951) |
| ➤ Prandtl (1921) | ➤ Hansen (1961) |
| ➤ Schleicher (1926) | ➤ Balla (1962) |
| ➤ Fellinius (1939) | ➤ Vesic (1975) |

Plate bearing tests are load tests conducted in the field on a plate at shallow depth. These involve effort and expense. There are some limitations also and these are mentioned in every book.

Penetration test is conducted with device known as penetrometer which measure the resistance of soil to penetration. This is correlated to bearing capacity.

Model and Prototype tests are very cumbersome and costly, and are not usually practicable.

Laboratory tests are simple, may be useful in arriving bearing capacity especially of pure clays.

Analytical Method: Bearing Capacity Equations

The following analytical approaches are available.

- **The theory of elasticity:** Schleicher's method
- **The classical earth pressure theory:** Rankine, Pauker, Bell
- **The theory of Plasticity:** Fellinius, Prandlt, Terzaghi, Meyerhof, Skempton, Hansen, Balla, Vesic

Terzaghi's Theory

Terzaghi (1948) developed a bearing capacity theory, assuming a failure surface consisting of three wedges (I, II and III) as illustrated in Fig.31 He considers a strip footing with rough base placed at a depth D_f on a homogeneous and isotropic soil mass. In the analysis the shearing resistance of the soil above the base (AA' and BB' in Fig. 1) of the footing is neglected, but the effect of soil weight above the base is considered by superimposing an equivalent surcharge of intensity $q = \gamma D_f$. The development of the failure surface in the soil is governed by the general shear failure.

The soil immediately beneath the foundation forms a wedge (zone I) which moves downwards. The movement of wedge forces the soil aside and produces two zones of shear (zone II and zone III), consisting of a radial shear zone (zone II) and a linear shear zone (zone III). Zone I is considered to be at Rankine active state, zone II under radial shear and zone III at Rankine passive state. On the verge of failure, $\Sigma V = 0$, thus

$$q_{ult} B = 2 P_p + 2 BC. c \sin \phi \quad (3.1)$$

Substituting $BC = B/2 \cdot \cos \phi$, (3.2)

$$q_{ult} B = 2 P_p + BC. \tan \phi \quad (3.3)$$

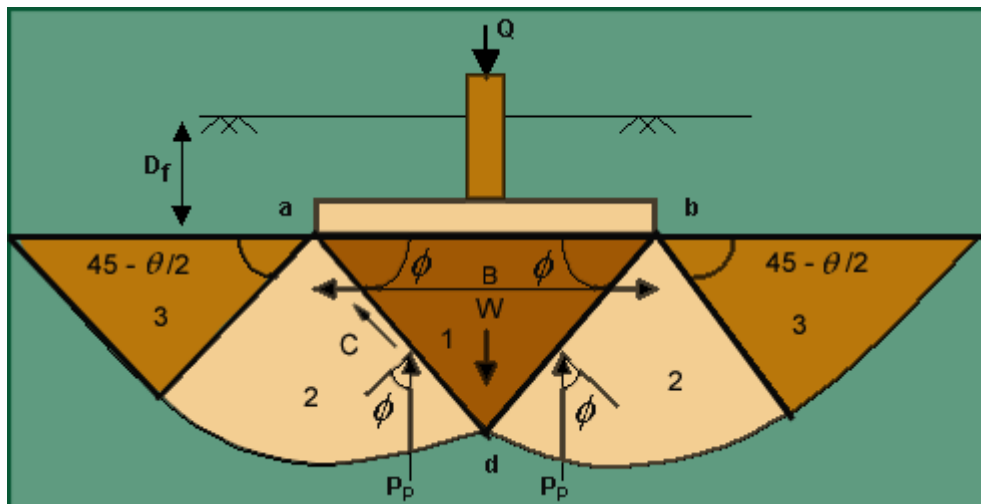

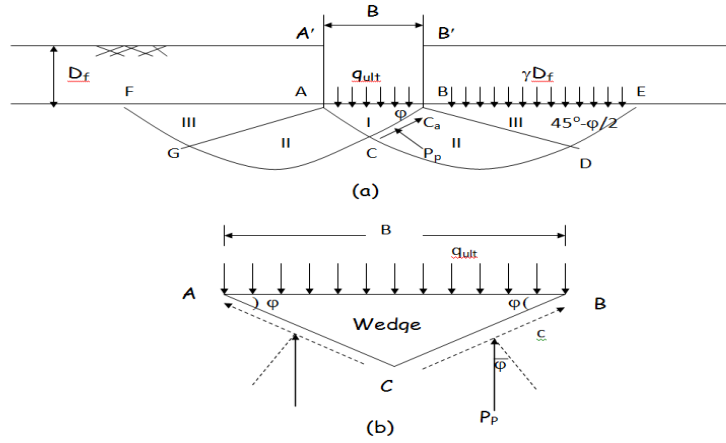

Figure 3.1: (a) failure mechanism; (b) forces on the elastic wedge (Terzaghi's bearing capacity theory)

The value of P_p has been represented as the vector sum of three components, (i) cohesion, (ii) surcharge and (iii) weight of the soil. Terzaghi assumed the method of superposition to be valid presented the unit ultimate bearing capacity in the form

$$q_{ult} = cN_c + \frac{1}{2} B \gamma N_\gamma + qN_q \quad (3.4)$$

Where, N_c , N_γ and N_q are nondimensional bearing capacity factors and functions only of the angle of internal friction, ϕ .

$$N_q = \frac{\exp\left[2\left(\frac{3\pi - \phi}{4} - \frac{\phi}{2}\right)\tan\phi\right]}{2 \cos^2\left(\frac{\pi}{4} + \frac{\phi}{2}\right)} \quad (3.5)$$

$$N_c = \cot\phi(N_q - 1) \quad (3.6)$$

$$N_\gamma = \frac{1}{2} \cdot \tan\left(\frac{K_{p\gamma}}{\cos^2\phi} - 1\right) \quad (3.7)$$

A close approximation of $K_{p\gamma}$ is given by

$$K_{p\gamma} = 3 \tan^2\left[45 + \left(\frac{\phi + 33}{2}\right)\right] \quad (3.8)$$

Terzaghi's bearing capacity factors are shown in Fig. 2

These bearing capacity factors are valid for strip footing only and require to be adjusted for rectangular and circular footings as follows. It is understood that square footing is a special case of rectangular footing where length of the footing, L equals to its width B .

Rectangular Footing:

$$N_{c-rect} = N_{c-strip} (1 + 0.3B/L) \quad (3.9)$$

$$N_{\gamma-rect} = N_{\gamma-strip} (1 - 0.2B/L) \quad (3.10)$$

$$N_{q-rect} = N_{q-strip} \quad (3.11)$$

Square Footing:

Circular Footing:

$$N_{c-square} = 1.3 N_{c-strip}$$

$$N_{\gamma-square} = 0.8 N_{\gamma-strip}$$

$$N_{q-square} = N_{q-strip}$$

$$N_{c-circle} = 1.3 N_{c-strip}$$

$$N_{\gamma-circle} = 0.6 N_{\gamma-strip}$$

$$N_{q-circle} = N_{q-strip}$$

As such, the following bearing capacity equations are used to estimate the ultimate bearing capacity of soil.

$$\text{Strip footing: } q_{ult} = cN_c + \frac{1}{2}B\gamma N_\gamma + qN_q \quad (3.12)$$

$$\text{Square footing: } q_{ult} = 1.3cN_c + 0.4 B\gamma N_\gamma + qN_q \quad (3.13)$$

$$\text{Circular Footing: } q_{ult} = 1.3cN_c + 0.3 B\gamma N_\gamma + qN_q \quad (3.14)$$

Recent research works reveal that the values of N_c , N_q and N_γ given by Terzaghi are conservative and the following formulas may be used for the computation of bearing capacity factors.

$$N_q = \tan^2\left(45 + \frac{\phi}{2}\right)e^\pi \tan \phi \quad (3.15)$$

$$N_c = (N_q - 1)\cot \phi \quad (3.16)$$

$$N_\gamma = 1.5(N_q - 1)\tan \phi \quad (3.17)$$

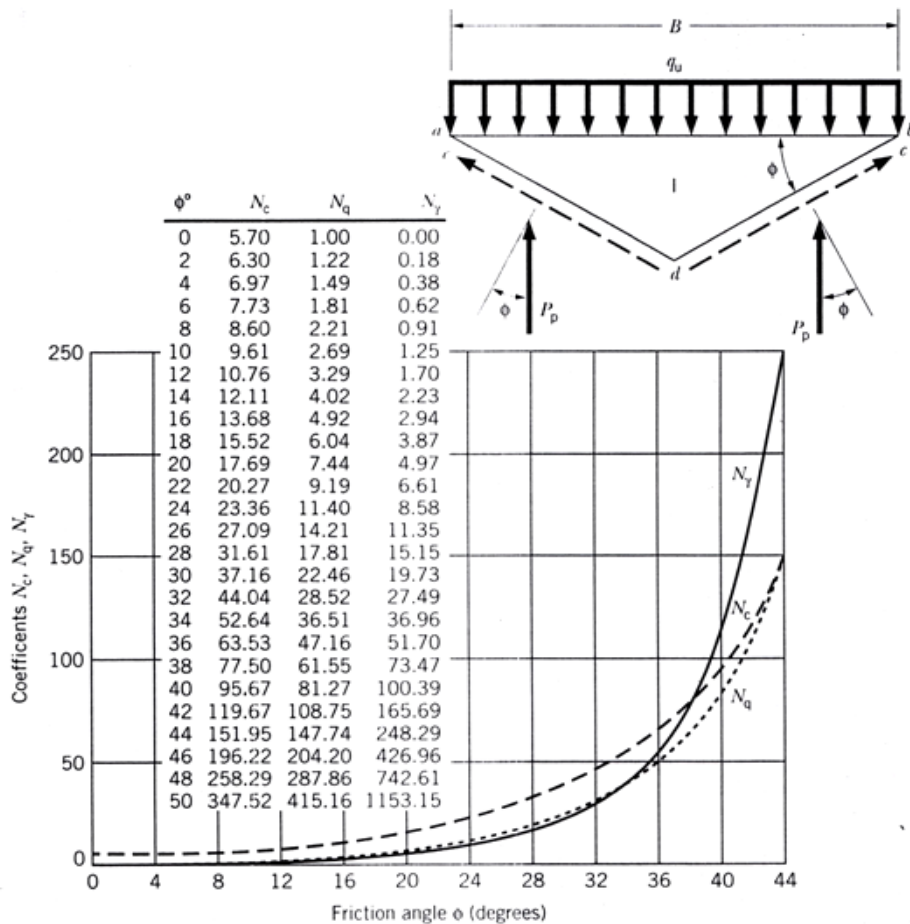

Figure 3.2: Terzaghi's bearing capacity factors

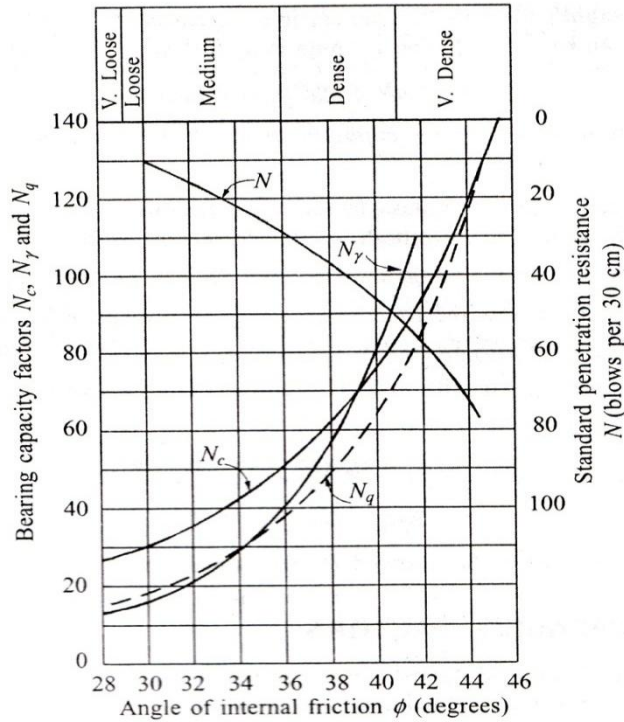

Figure 3.3: Terzaghi's general bearing capacity factors against SPT values for cohesionless soils

Peak, Hanson and Thornburn proposed a chart for practical use where bearing capacity factors can be obtained against SPT values for cohesionless soil. The SPT values are however to be corrected for overburden and water table. The chart is presented in Fig. 3.3.

Problem 3.1: Determine the ultimate net bearing capacity of a 2.5 m circular footing resting at a depth of 1.5 m below ground level. The water table is at great depth. The foundation soil is pure clay with the following properties: $c_u=50$ kPa, $\phi=0$, $\gamma=16$ kN/m³, $N_c=5.7$, $N_q=1$, $N_\gamma=0$. Also calculate the ultimate net bearing capacity, if the ground water table is at ground level. Solve the problem assuming 2.5 m square footing.

Meyerhof's Theory

Meyerhof (1951) considered the effects of shearing resistance within the soil above foundation level, the shape and roughness of foundation, and derived a general bearing capacity equation. According to Meyerhof,

$$\text{For vertical Load: } q_{ult} = cN_c S_c d_c + \frac{1}{2} B \gamma N_\gamma S_\gamma d_\gamma + q N_q S_q d_q \quad (3.18)$$

$$\text{For inclined load: } q_{ult} = cN_c S_c d_c + \frac{1}{2} B \gamma N_\gamma S_\gamma d_\gamma + q N_q S_q d_q i_q \quad (3.19)$$

Where,

$$N_q = \exp^{\pi \tan \phi} \tan^2(\pi/4 + \phi/2) \quad (3.20)$$

$$N_c = (N_q - 1) \cot \phi \quad (3.21)$$

$$N_\gamma = (N_q - 1) \cdot \tan(1.4 \phi) \quad (3.22)$$

S , d and i 's are known as shape, depth and load inclination factors respectively to be used along with the bearing capacity factors N_c , N_γ and N_q as indicated by their subscript. The bearing capacity factors N_c , N_γ and N_q as obtained by Meyerhof's theory are presented in Fig. 3.11. The other associated factors are given in Table 3.2. Meyerhof also suggested considering the reduced footing dimensions to account for load eccentricity in calculating ultimate bearing capacity. Accordingly, modified length, L' and width, B' of the footing are given by

$$L' = L - 2e_x; \text{ and } B' = B - 2e_y \quad (3.23)$$

Where, e_x and e_y represents the load eccentricity in longer (along the length L) and shorter (along the width B) directions respectively. He also suggested the use of plain strain ϕ in the bearing capacity equations. The triaxial ϕ should be adjusted to obtain plain strain ϕ using the formula: $\phi_{ps} = (1.1 - 0.1B/L) \phi_{triaxial}$

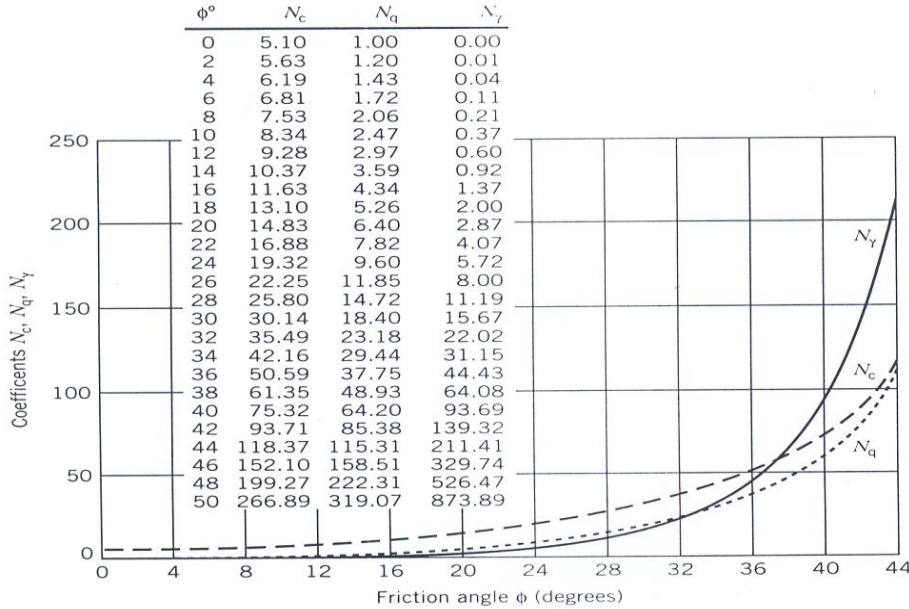

Figure 3.4: Meyerhof's bearing capacity factors

Table 3.1: Meyerhof's factors for shape, depth and load inclination (after Cernica, 1995)

Friction, angle ϕ	Shape factors	Depth factors	Inclination factors
Any ϕ	$S_c = 1 + 0.2K_p B/L$	$d_c = 1 + 0.2\sqrt{K_p} D/B$	$i_c = i_q = (1 - \alpha/90^\circ)^2$
For $\phi = 0^\circ$	$S_\gamma = S_q = 1.0$	$d_\gamma = d_q = 1.0$	$i_\gamma = 1.0$
For $\phi \geq 10^\circ$	$S_\gamma = S_q = 1 + 0.1K_p B/L$	$d_\gamma = d_q = 1 + 0.1\sqrt{K_p} D/B$	$i_q = (1 - \alpha/\phi)$

$K_p = \tan^2(45^\circ + \phi/2)$
 $\alpha =$ angle of resultant measured from vertical axis.

Skempton's Bearing Capacity Equation for Clay Soil

Skempton (1951) proposed equations for bearing capacity of footings founded on purely cohesive soils based on extensive investigations. According to him the bearing capacity factor N_c is a function of the depth of foundation and also of its shape. The equation for net ultimate bearing capacity, $q_{net-ult}$ is as follows:

$$q_{net-ult} = cN_c \quad (3.24)$$

The bearing capacity factor, N_c is given by:

For strip footing:

$$N_c = 5(1 + 0.2 D_f/B) \quad (3.25)$$

With a limiting value of N_c of 7.5 for D_f/B greater than 2.5.

For square and circular footings:

$$N_c = 6(1 + 0.2 D_f/B) \quad (3.26)$$

With a limiting value of N_c of 9.0 for D_f/B greater than 2.5 B is the width of strip, side of square or diameter of a circular footing.

For rectangular footings:

$$N_c = 5(1 + 0.2 B/L) (1 + 0.2 D_f/B) \quad \text{for } D_f/B \leq 2.5 \quad (3.27)$$

And

$$N_c = 7.5(1 + 0.2 B/L) \quad \text{for } D_f/B > 2.5. \quad (3.28)$$

Where, B and L are breadth and length respectively, of the rectangular footing. Skempton's bearing capacity factor N_c for different shapes and depths of foundation can be obtained directly from Figure

Table 3.2: Comparative statement of bearing capacity factors

ϕ°	Terzaghi			Meyerhof			Hansen		
	N_c	N_q	N_γ	N_c	N_q	N_γ	N_c	N_q	N_γ
0	5.70	1.00	0.00	5.10	1.00	0.00	5.10	1.00	0.00
2	6.30	1.22	0.18	5.63	1.20	0.01	5.63	1.20	0.01
4	6.97	1.49	0.38	6.19	1.43	0.04	6.19	1.43	0.05
6	7.73	1.81	0.62	6.81	1.72	0.11	6.81	1.72	0.11
8	8.60	2.21	0.91	7.53	2.06	0.21	7.53	2.06	0.22
10	9.61	2.69	1.25	8.34	2.47	0.37	8.34	2.47	0.39
12	10.76	3.29	1.70	9.28	2.97	0.60	9.28	2.97	0.63
14	12.11	4.02	2.23	10.37	3.59	0.92	10.37	3.59	0.97
16	13.68	4.92	2.94	11.63	4.34	1.37	11.63	4.34	1.43
18	15.52	6.04	3.87	13.10	5.26	2.00	13.10	5.26	2.08
20	17.69	7.44	4.97	14.33	6.40	2.37	14.83	6.40	2.95
22	20.27	9.19	6.61	16.88	7.82	4.07	16.88	7.82	4.13
24	23.36	11.40	8.58	19.32	9.60	5.72	19.32	9.60	5.75
26	27.09	14.21	11.35	22.25	11.85	8.00	22.25	11.85	7.94
28	31.61	17.81	15.15	25.80	14.72	11.19	25.80	14.72	10.94
30	37.16	22.46	19.73	30.14	18.40	15.67	30.14	18.40	15.07
32	44.04	28.52	27.49	35.49	23.18	22.02	35.49	23.18	20.79
34	52.64	36.51	36.96	42.16	29.44	31.15	42.16	29.44	28.77
36	63.53	47.16	51.70	50.59	37.75	44.43	50.59	37.75	40.05
38	77.50	61.55	73.47	61.35	48.93	64.08	61.35	48.93	56.18
40	95.67	81.27	100.39	75.32	64.20	93.69	75.32	64.20	79.54
42	119.67	108.75	165.69	93.71	85.38	139.32	93.71	85.38	113.96
44	151.95	147.74	248.29	118.37	115.31	211.41	118.37	115.31	165.58
46	196.22	204.20	426.96	152.10	158.51	329.74	152.10	158.51	244.65
48	258.29	287.86	742.61	199.27	222.31	526.47	199.27	222.31	368.68
50	347.52	415.16	1153.15	266.89	319.07	873.89	266.89	319.07	568.59

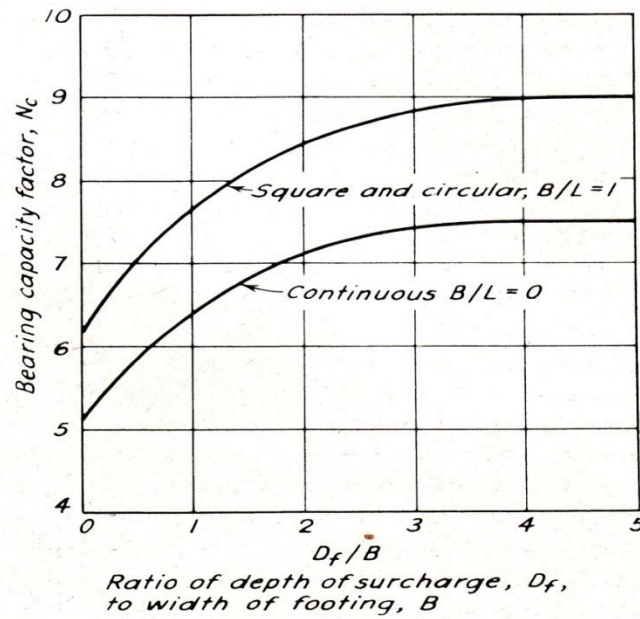

Figure 3.5: Skempton's bearing capacity factors for clay soils

Effect of Water Table on Bearing Capacity

The general bearing capacity equation is based on the assumption that the water table is located well below the foundation level. The equation contains unit weight, γ , cohesion, c and the bearing capacity factors, N_c , N_γ and N_q that depend on the value of ϕ . As such, some modifications are necessary in the formulation to account for the effect of water table.

In the general equation there are two terms which are affected by water table movement, (i) the soil weight component that is, $\frac{1}{2}B \cdot \gamma \cdot N_\gamma$; and (ii) the surcharge component, $\gamma D_f \cdot N_q$.

Let us consider three locations of water table, as illustrated in Figure

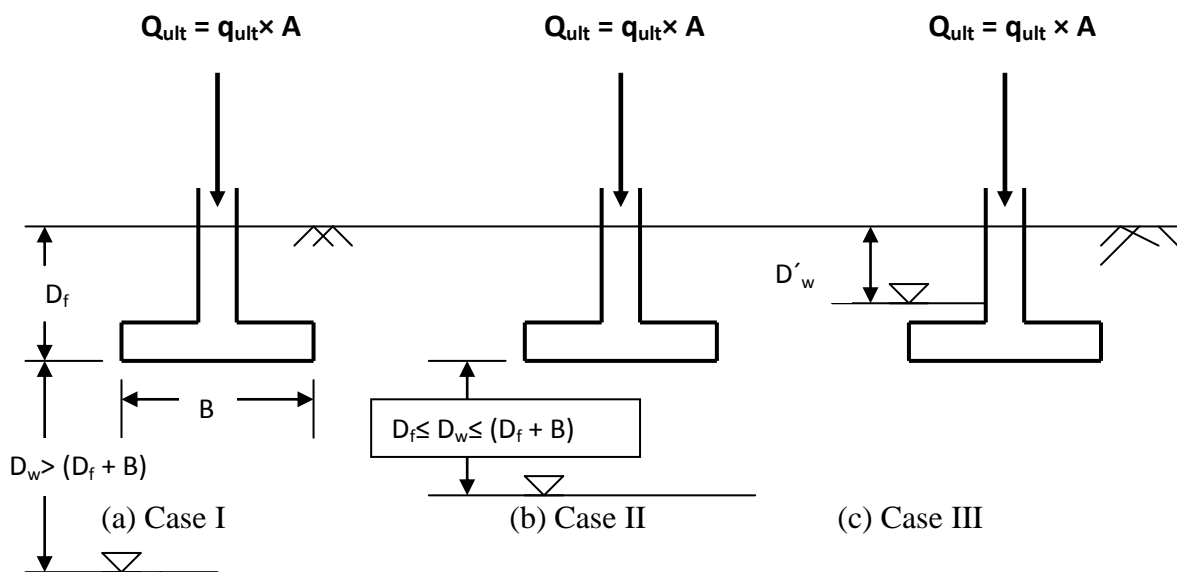

Figure 3.6: Effect of water table and correction factors

Case I: When the water table is well below the foundation, that is $D_w > (D_f + B)$. For this case no correction is needed for both the components.

Case II: When the water table is anywhere from the base of the footing to a level of well below the foundation, that is $-D_f \leq D_w \leq (D_f + B)$. In this case, only the weight component is affected; whereas surcharge component remains unaffected. The aspect can be considered by substituting an equivalent unit weight γ_e in place of γ . That is,

$$\gamma_e = [d_w \gamma + (B - d_w) \gamma'] / B \quad (3.29)$$

or,
$$\gamma_e = \gamma' + d_w / B (\gamma - \gamma') \quad \bar{\gamma} = \gamma' + \left(\frac{D_w - D_f}{B} \right) (\gamma - \gamma') \quad (3.30)$$

Case III. When the water table is anywhere between the ground surface and the base of the footing, that is $0 \leq d'_w \leq D_f$. $D_w \leq D_f$ In this case both the components are affected. For the surcharge component, the equivalent surcharge is

$$q = D_w \gamma + (D_f - D_w) \gamma' \quad (3.31)$$

For the soil weight component, the required substitution in the formula is γ' in place of γ in the term $\frac{1}{2} B \gamma N_\gamma$. Teng(1962) suggested water table correction factors, as the unit weight of soil as 50% of its bulk unit weight. Considering case III, when the water table is at the ground surface, $d'_w / D_f = 0$ and $\gamma = \gamma'$. While water table is at the base of the footing $d'_w / D_f = 1$ and $\gamma = \gamma_{sat}$. This suggests a correction factor to have a value of 0.5 at $d'_w / D_f = 0$ and 1.0 at $d'_w / D_f = 1$. The general expression assuming linear variation is $R'_w = \frac{1}{2}(1 + d'_w / D_f)$.

Considering case II, for $d_w / B = 0$, the correction factor is 0.5 when water table is at the base ; for $d_w / B = 1$, the correction factor should be 1.0. The general expression is for correction factor is $R_w = \frac{1}{2}(1 + d_w / B)$. Hence, the bearing capacity formula takes the form

$$Q = cN_c + \frac{1}{2} R_w B \gamma N_\gamma + R'_w q N_q \quad (3.32)$$

Case I requires no correction for water table.

Effect of Layering of Soil

When footing rests on a multilayer deposit, Bowles recommends that the ultimate bearing capacity of the footing be determined using average values of cohesion, c_{av} and the angle of internal friction ϕ_{av} . The average values are computed over a depth H below the base of the footing, where:

$$H = \sum_{i=1}^n h_i = 0.5B \tan\left(45 + \frac{\phi}{2}\right) \quad (3.33)$$

c_{av} and ϕ_{av} are given by

$$c_{av} = \frac{\sum c_i h_i}{\sum h_i} \quad (3.34)$$

$$\tan(\phi_{av}) = \frac{\sum h_i \tan \phi_i}{\sum h_i} \quad (3.35)$$

If necessary any value of h_i may be multiplied by a suitable weighing factor. Average parameters should be determined, Fig. 3.16, by trial and error, since the term H used in the equation itself dependent on ϕ_{av} .

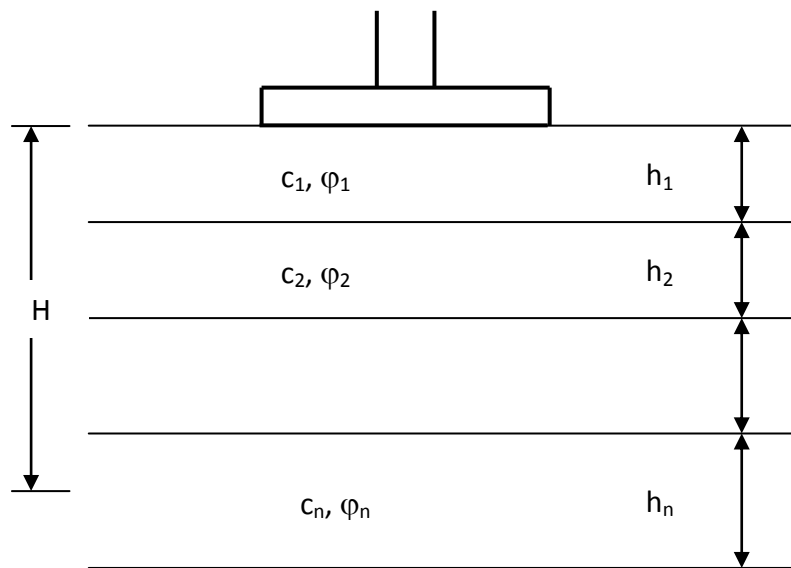

Figure 3.7: Bearing capacity of multilayered soil system

Corrections for Different Modes of Failure

There are mainly three principal modes of shear failure namely general shear, local shear and punching shear. They are illustrated in Fig. 3.17.

General Shear Failure: This occurs when a clearly defined plastic yield slip surface forms under the footing and develops outward towards one or sides and eventually to the ground surface. Failure is sudden and will often be accompanied by severe tilting leading to final collapse on one side. This mode of failure is associated with dense and overconsolidated soils of low compressibility.

Local Shear Failure: In compressible soils, significant vertical movement may take place before any noticeable development of shear planes occurs. As the soil beneath the footing reaches the yield condition shear planes develop, but fail to extend to the ground surface. Some adjacent bulging may occur, but very little tilting takes place. The settlement, which occurs, will usually be the principal design criteria.

Punching Shear Failure: In weak compressible soils, considerable vertical movement may take place with the development of slip surface restricted to vertical planes adjacent to the sides of the footing. Bulging at the surface is usually absent and may even be replaced by drag down.

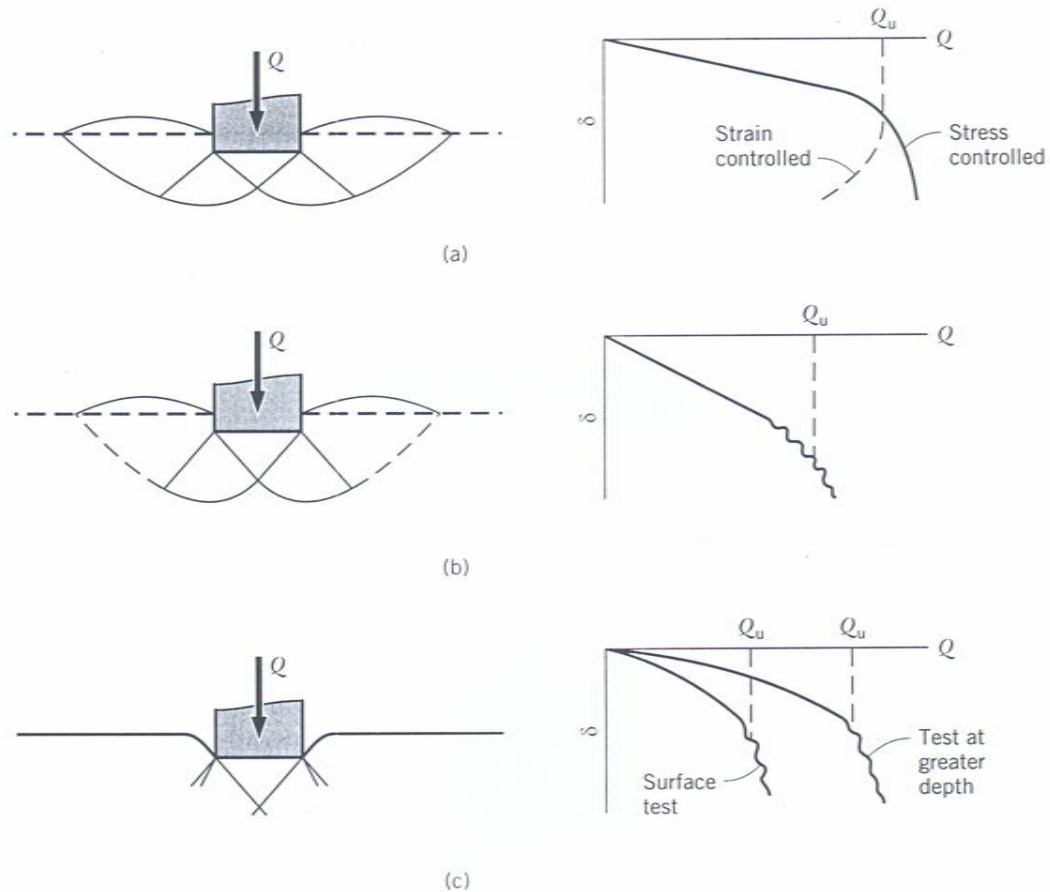

Figure 3.8: Modes of failure of foundation soil; (a) General shear; (b) Local shear; (c) Punching shear

Correction Factors

Terzaghi developed his bearing capacity equations assuming a general shear failure. For failures other than general shear he proposed reduced values of c and ϕ as:

$$c' = 0.67c ; \quad \phi' = \tan^{-1}(0.67 \tan \phi) \quad (3.36)$$

The ultimate bearing capacity is to be determined using the corrected values of c and ϕ .

Vesic (1975) suggests the following modification of ϕ in case of sandy soil.

$$\phi^* = \tan^{-1}[(0.67 + I_D - 0.75I_D^2)\tan \phi], \quad \text{for } 0 \leq I_D \leq 0.67 \quad (3.37)$$

$$\phi^* = \phi, \quad \text{for } I_D > 0.67 \quad (3.38)$$

Allowable Bearing Capacity

Allowable bearing capacity is the minimum of the safe net bearing capacity (determined from considerations of shear failure) and safe bearing pressure (determined from considerations of permissible settlement). When wind and seismic forces are considered in design the allowable bearing capacity is suitably designed accordingly.

Safe net bearing capacity is the maximum net intensity of loading that the foundation will safely carry without the risk of shear failure of soil irrespective of any amount of settlement that may occur. It is obtained by dividing the ultimate net bearing capacity by a suitable factor of safety.

$$q_{safe-net} = q_{ult-net} / FS \quad (3.39)$$

Ultimate net bearing capacity is the net intensity of loading at the base of the foundation which would cause shear failure of soil. This is obtained as the difference of ultimate bearing capacity (q_{ult}) and the effective surcharge intensity (q) at the base level of foundations.

$$q_{ult-net} = q_{ult} - q \quad (3.40)$$

Hence, the equation for ultimate net bearing capacity for a strip footing considering general shear will take the form

$$q_{ult-net} = cN_c + \frac{1}{2} B\gamma N_\gamma + q(Nq - 1) \quad (3.41)$$

Safe bearing pressure ($q_{safe-pr}$) is the maximum net intensity of loading that can be imposed on the soil by the foundation without the settlement exceeding the permissible value to be determined for each type of structure and type of soil.

Allowable Bearing Capacity for Sandy Soil

For sandy soil safe bearing pressure is usually determined from its empirical correlations with SPT value as suggested by Terzaghi and Peck, shown in Fig. 3.18. It gives the bearing pressure for permissible settlement of 25 mm. For any other value of permissible settlement the safe bearing pressure can be linearly extrapolated. For any value of permissible settlement, S_p , the safe bearing pressure is given by

$$q_{safe-pr, Sp} = (q_{safe-pr}/25) \cdot S_p \cdot C_w \cdot C_D \quad (3.42)$$

Average value of measured N should be within a zone of $2B$ below the base of the footing. C_w and C_D are the correction factors of N for water table and overburden respectively.

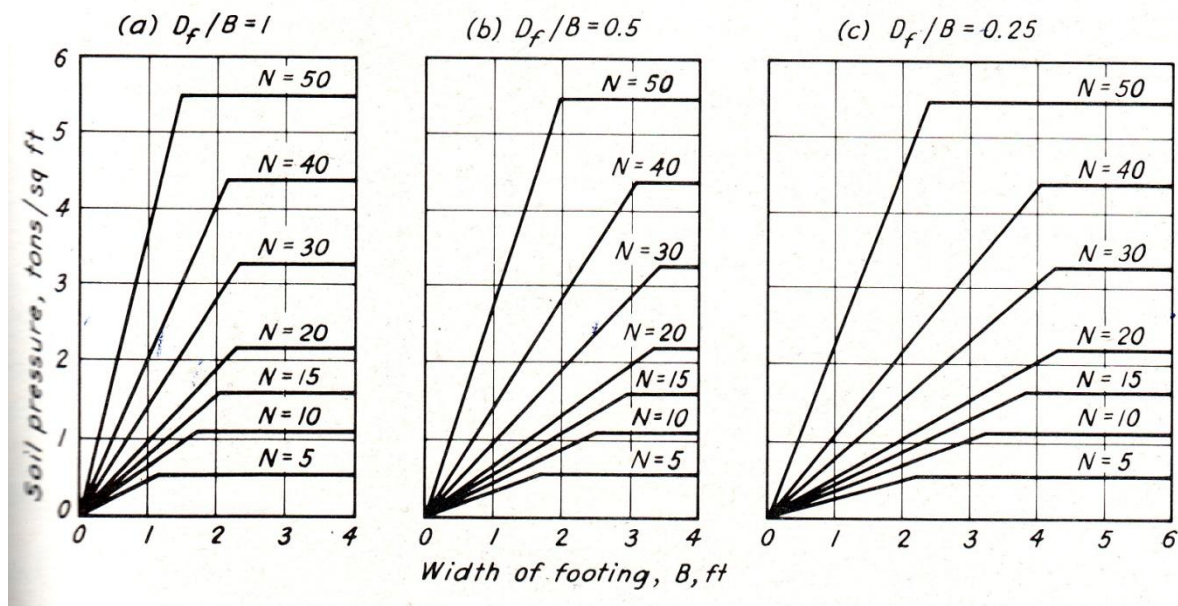

Figure 3.9: Correlation between $q_{safe-net}$ and N value

Allowable Bearing Capacity for Clayey Soil

Allowable bearing capacity is estimated comparing the safe bearing pressure against settlement and safe bearing capacity against shear failure of foundation soil.

Safe bearing pressure for clay soil is estimated considering settlement of foundation soil due to load. The total amount of settlement includes elastic, consolidation and secondary compressions.

Safe net bearing capacity of clay soil is usually determined using Skemton's formula for ultimate bearing capacity and a suitable factor of safety. For a continuous footing in clay ultimate net bearing capacity can be expressed in terms of unconfined compressive strength, q_u and is given by:

$$q_{ult-net} = cN_c = 2.85 q_u \quad (3.43)$$

Using a factor of safety of 3, for a strip footing, we get the relationship:

$$\frac{q_{ult-net}}{FS} = \frac{2.85q_u}{3} = 0.95q_u \approx q_u \quad (3.44)$$

Thus gross safe bearing capacity is:

$$q_{safe-gross} = \frac{q_{ult-net}}{FS} + \gamma D_f = q_u + \gamma D_f \quad (3.45)$$

Peak, Hansen and Thornburn proposed a set of curves for the safe bearing capacity as shown in Fig. 3.20.

Unlike that of sandy soil allowable bearing capacity is usually governed by the safe bearing capacity rather than the safe bearing pressure. As such Fig. 3.19 may be used as a design chart for clayey soils.

Selection of Factor of Safety

The factor of safety used in shallow foundation design depends on factors like design maximum load that coming on the foundation, shapes of foundation and the extent of subsoil investigation carried at the site.

- (a) For structures where maximum loads are likely to occur **often like railway bridges, water tanks etc., the factor of safety (FS) should be 3 to 4.**
- (b) Where the maximum loads occur occasionally as in highway bridges, FS should be 2.5 to 3.5.
- (c) When maximum loads are not likely to occur as in residential buildings, the factor of safety should be 2.0 to 3.0.

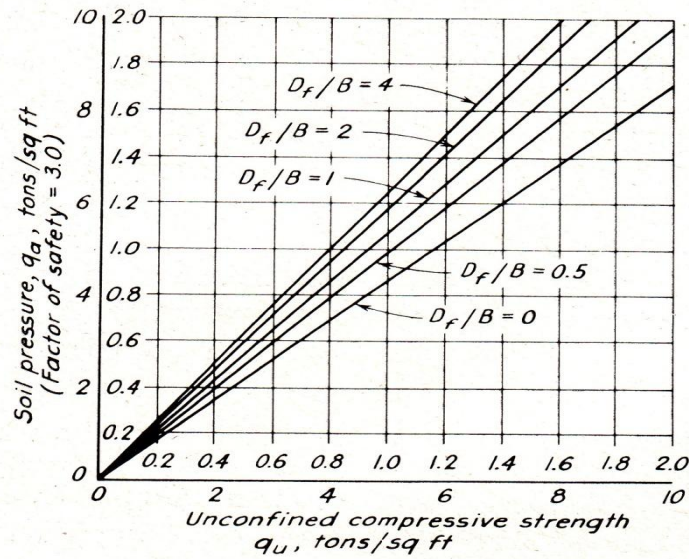
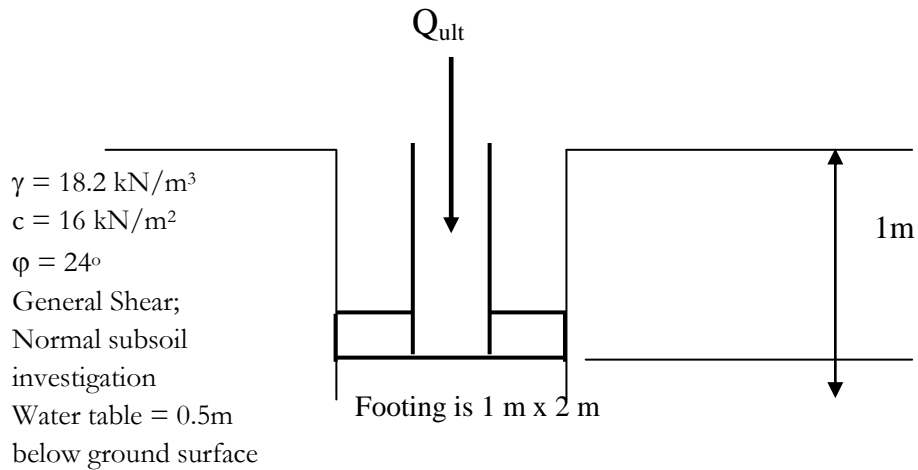

Figure 3.10: Safe bearing capacity of footing in clay

Where extensive soil investigation has been done the lower value of the range is suggested; in case of limited subsoil investigation the higher ranges of factor of safety has been recommended. Bowles suggested to following factor of safety for the types of foundation.

Spread Footing:	2 to 3
Mat Foundation:	1.7 to 2.5
Footing Subjected to Uplift Forces:	1.7 to 2.5

Problem 3.2: Determine ultimate and allowable bearing capacities of the footing using Terzaghi and Meyerhof's equations.



From the previous problem, using the column load and the soil test report of the site given below, calculate the bearing capacity and footing size.

Bearing Capacity is a general term used to describe, the load carrying capacity of a foundation soil that enables to bear and transmit loads from a structure.

*** Using Terzaghi's equation:**

This equation can be used both for cohesionless and cohesive soil. The common equation is-

$$q_{ult} = cN_c + \frac{1}{2} B\gamma N_\gamma + qN_q$$

Where, N_c , N_γ and N_q are nondimensional bearing capacity factors and functions only of the angle of internal friction, ϕ .

Strip footing: $q_{ult} = cN_c + \frac{1}{2}B\gamma N_\gamma + qN_q$

Square footing: $q_{ult} = 1.3cN_c + 0.4 B\gamma N_\gamma + qN_q$

Circular Footing: $q_{ult} = 1.3cN_c + 0.3 B\gamma N_\gamma + qN_q$

$$N_q = \tan^2(45 + \frac{\phi}{2})e^{\pi \tan \phi}$$

$$N_c = (N_q - 1) \cot \phi$$

$$N_\gamma = 1.5(N_q - 1) \tan \phi$$

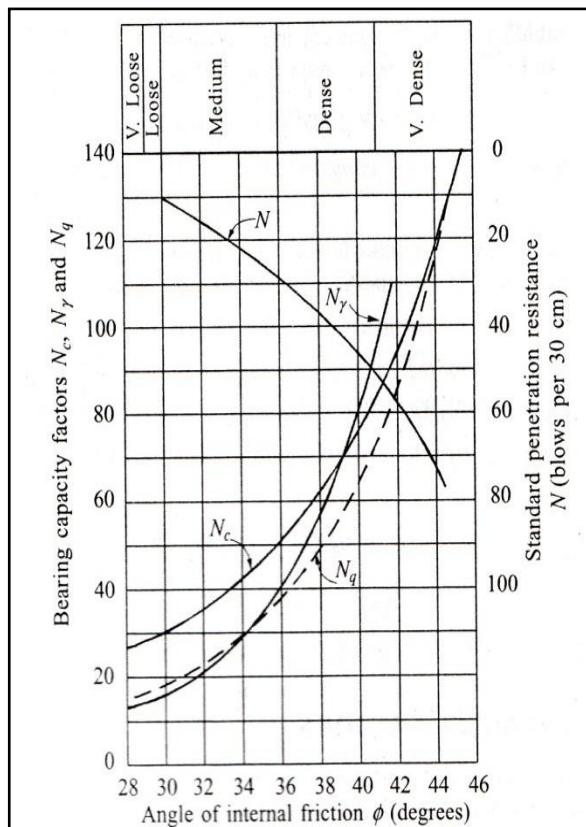

Figure 3.11: Terzaghi's general bearing capacity Factors against SPT values for cohesionless soils

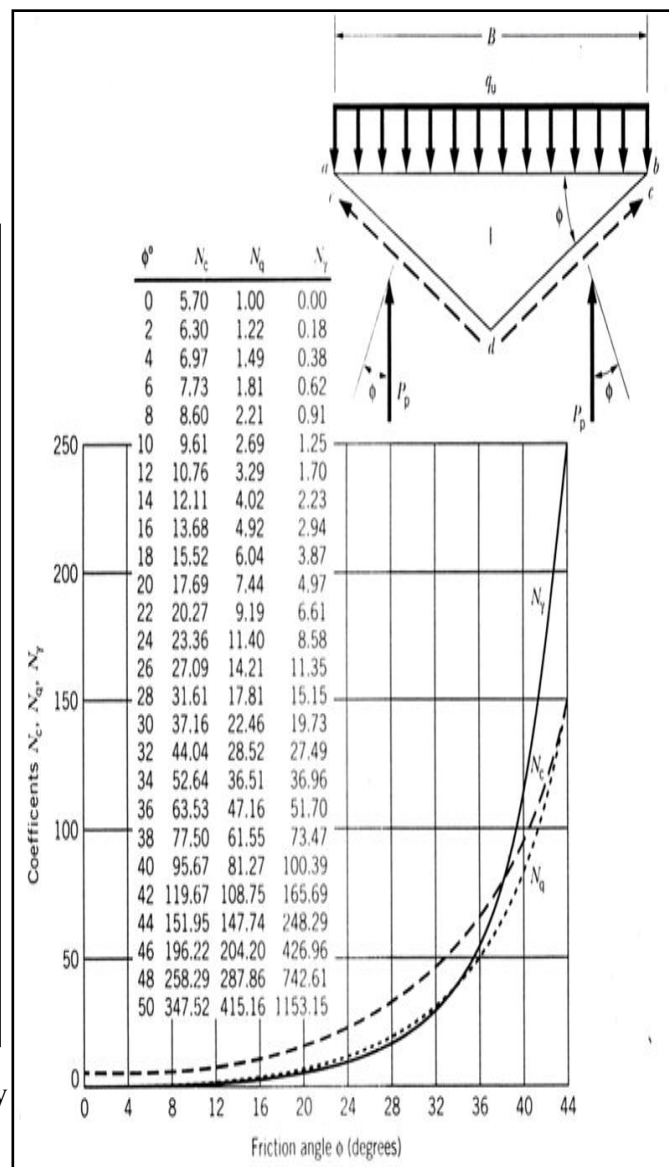

Figure 3.12: Terzaghi's bearing capacity factors

Calculation of bearing capacity

Column	B (Let)	Depth of foundation D_f	Cohesion $C = \frac{q_u}{2}$ (q_u =unconfined compressive strength)	Angel of internal friction ϕ .	Bearing Capacity factors			Ultimate bearing capacity q_{ult}	Allowable bearing capacity $q_{all} = \frac{q_{ult}}{F.S.}$
					N_c	N_q	N_γ		

Calculation of footing size

Column	Column load	Allowable bearing capacity q_{all}	Footing Area = $\frac{Load}{q_{all}}$	B = \sqrt{area} (for square footing)	B (rounded)	Check B ok/ not

* If the calculated B is less than the B that you let, then it is ok but not economical. The calculated B should be a nearest value of the B that you let but should not exceed the value.

* Using Skempton's Bearing Capacity Equation for Clay Soil

Skempton (1951) proposed equations for bearing capacity of footings founded on purely cohesive soils based on extensive investigations

$$q_{ult} = cN_c$$

The bearing capacity factor, N_c is given by

For strip footing:

$$N_c = 5(1 + 0.2 D_f/B)$$

For square and circular footings:

$$N_c = 6(1 + 0.2 D_f/B)$$

For rectangular footings:

$$N_c = 5(1 + 0.2 B/L)(1 + 0.2 D_f/B) \quad \text{for } D_f/B \leq 2.5$$

And $N_c = 7.5(1 + 0.2 B/L)$ for $D_f/B > 2.5$.

Or from the graph

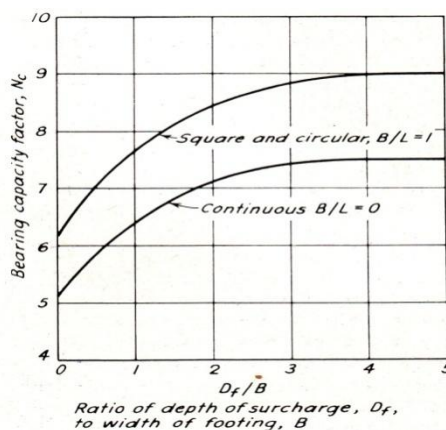

Figure 3.13: Skempton's bearing capacity factors for clay soils

Calculation of bearing capacity

Column	Depth of foundation D_f	Cohesion $C = \frac{q_u}{2}$ (q_u =unconfined compressive strength)	Bearing Capacity factor N_c	Ultimate bearing capacity q_{ult}	Allowable bearing capacity $q_{all} = \frac{q_{ult}}{F.S.}$

Calculation of footing size

Column	Column load	Allowable bearing capacity q_{all}	Footing Area = $\frac{Load}{q_{all}}$	$B = \sqrt{area}$ (for square footing)	B (rounded)	Check B ok/ not

* If the calculated B is less than the B that you let, then it is ok but not economical. The calculated B should be a nearest value of the B that you let but should not exceed the value.

CHAPTER 4

BEARING CAPACITY OF PILE FOUNDATION

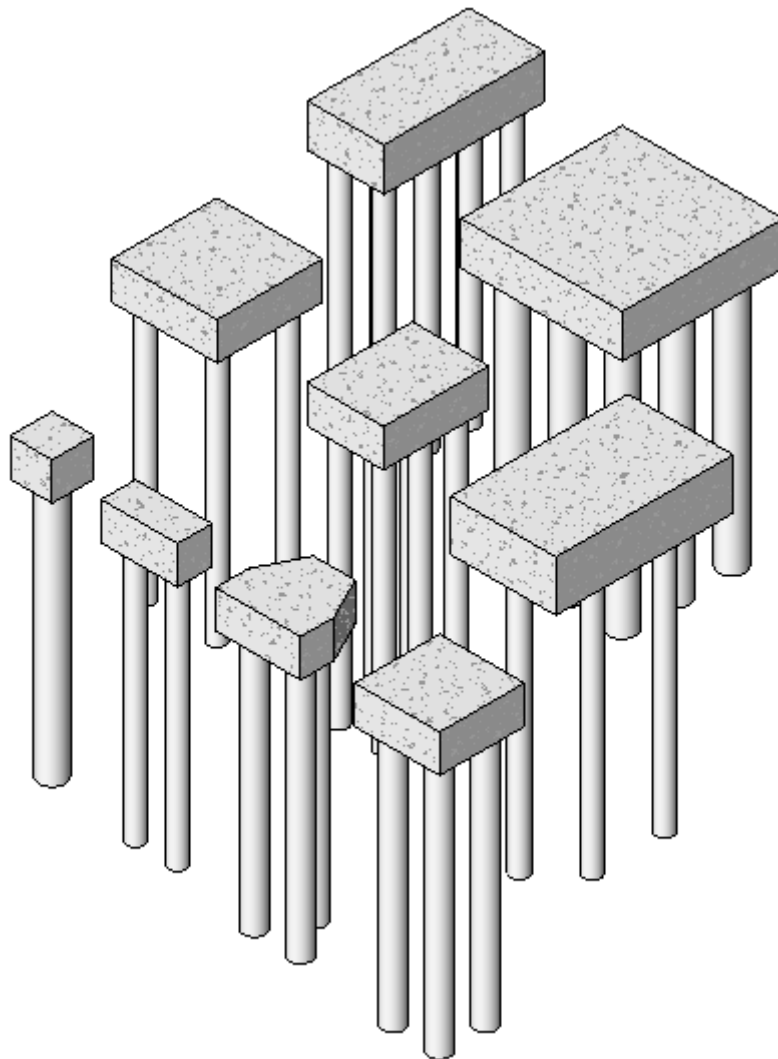

$$\text{Group action of Pile Cap} = \frac{2}{3} \times \text{Capacity of group pile}$$

Pile Foundation Type

There are **Four** types of Pile Foundation based on **Materials**

1. Timber Pile **or** Wooden Pile
2. Concrete Pile
3. Steel Pile
4. Composite Pile

There are **Two** types of Pile Foundation based on **Construction Method**

1. Cast in-situ Pile **or** Bored Pile **or** Drilled Pile &
2. Pre-cast Pile **or** Driven Pile

There are **Two** types of Pile Foundation based on **Load Transfer**

1. End Bearing Pile (Load is Transferred from depth L)
2. Friction Pile (Load is Transferred from depth $\frac{2}{3} L$)

L = Total Depth of Pile

Pile Foundation Design

We consider two types in design on Bearing Capacity -

1. Individual Action Capacity

$$\text{Total Capacity} = \text{Capacity of 1 Pile} \times \text{No. of Pile}$$

2. Group Action Capacity

Inter pile spacing = $3 \times \text{Diameter of Pile}$ \rightarrow Efficiency 80%

Inter pile spacing = $2.5 \times \text{Diameter of Pile}$ \rightarrow Efficiency 70%

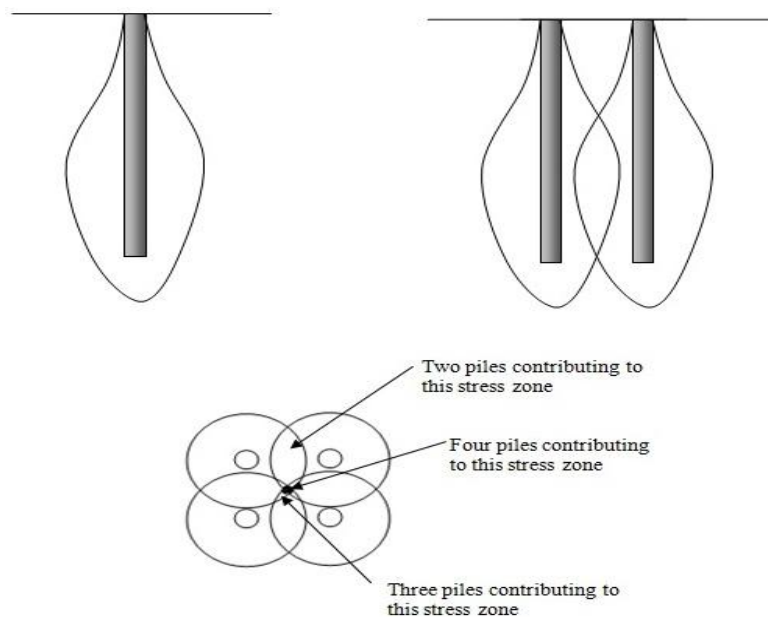

Figure 4.1: Individual and Group Action Capacity

Pile, Pile Cap & Column Position

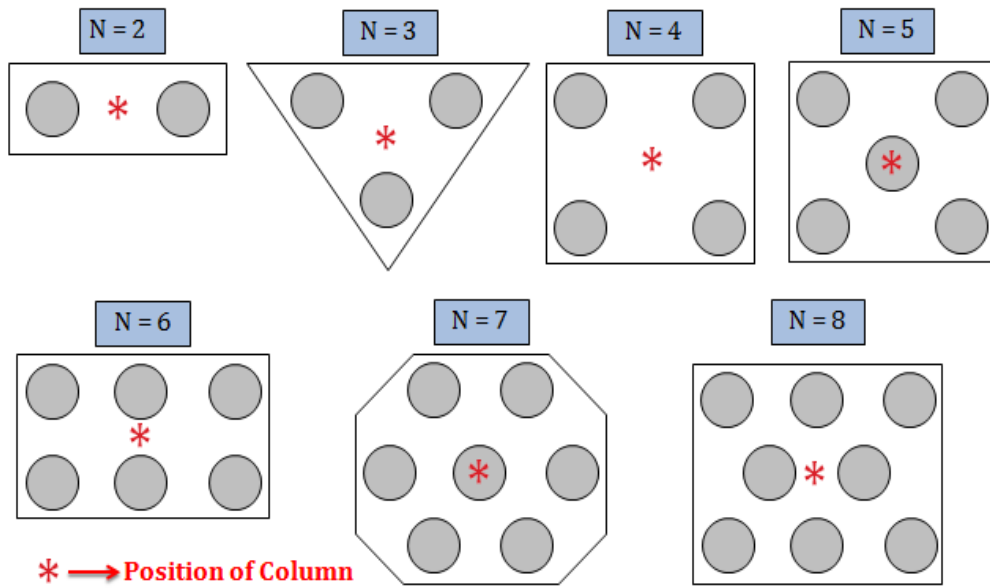

Figure 4.2: Pile, Pile Cap & Column Position

Pile Spacing

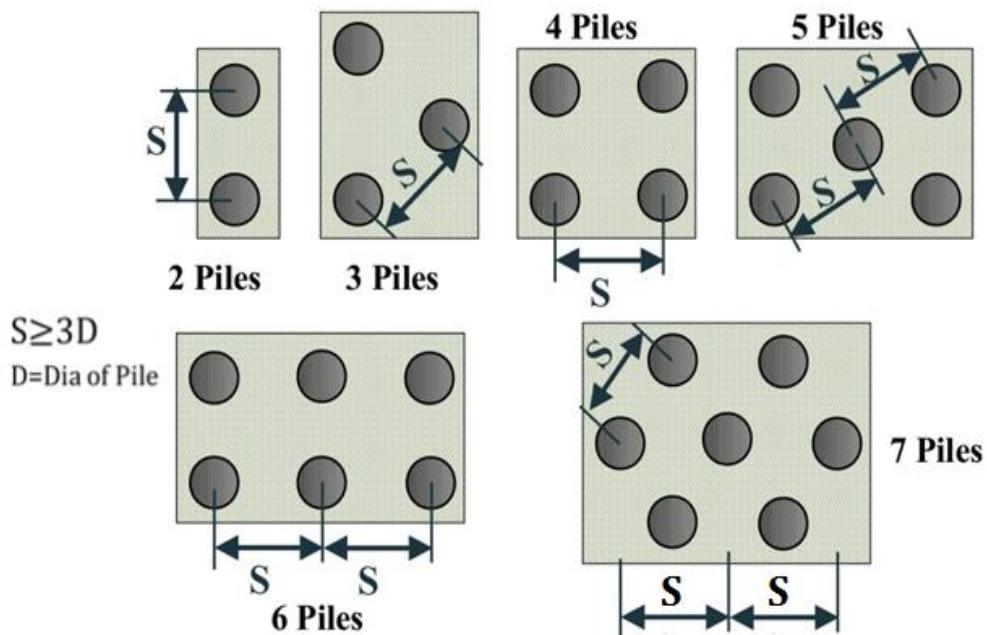

Figure 4.3: Pile Spacing

Bored Pile In Clay

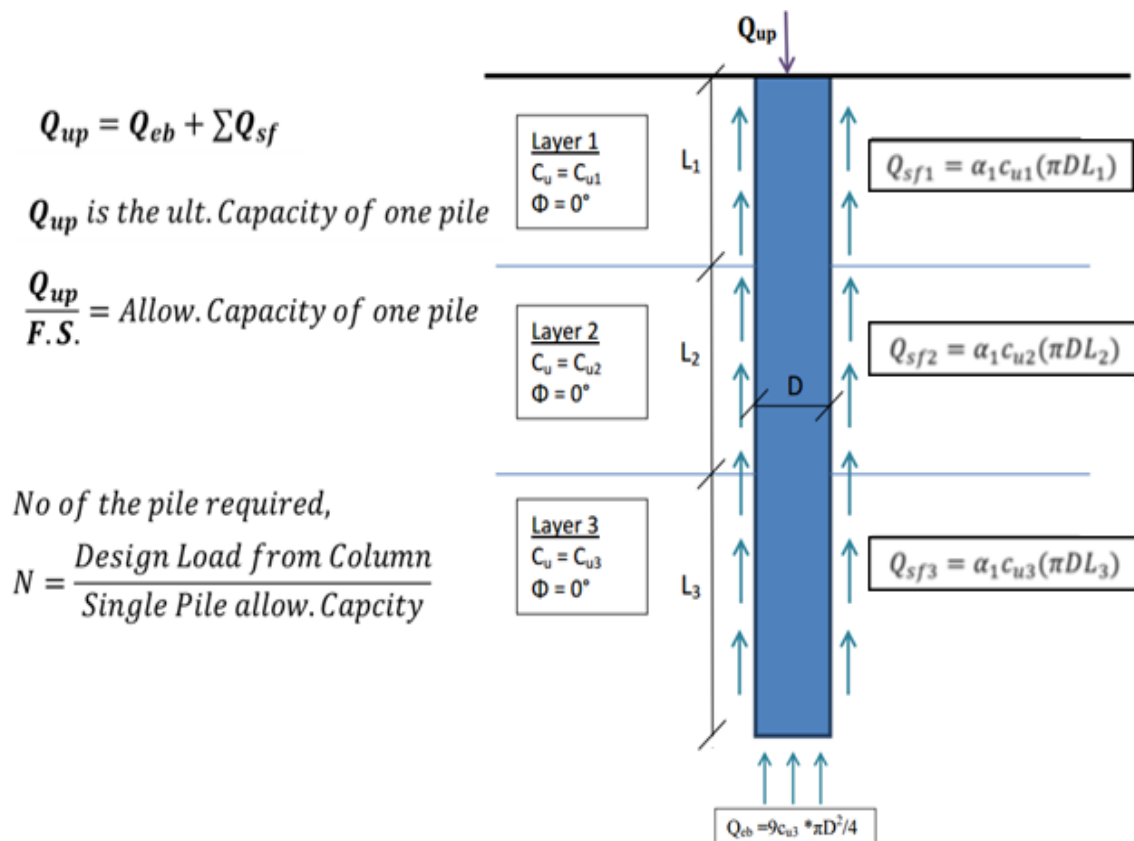
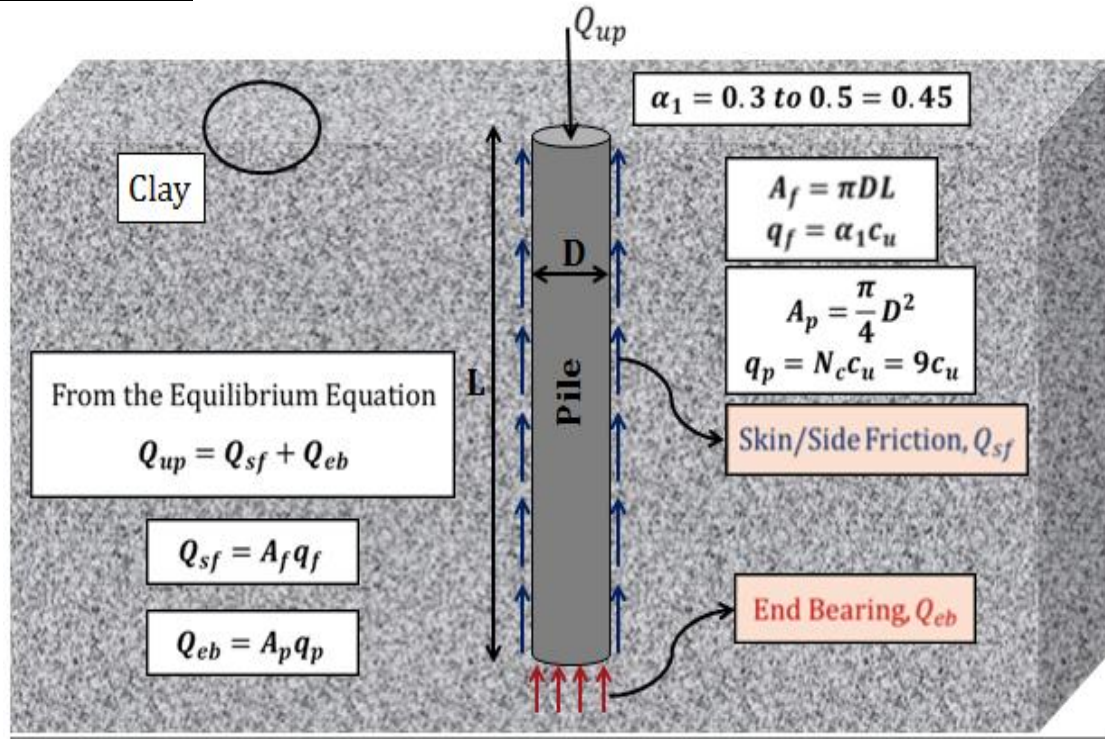

Figure 4.4: Bored Pile in Clay

The ultimate bearing capacity of a pile is considered to be the sum of end bearing resistance and the resistance due to skin friction

$$Q_{up} = Q_{eb} + Q_{sf} \quad (4.1)$$

where,

- Q_{up} = Ultimate bearing load of the pile
- Q_{eb} = End bearing resistance of the pile
- Q_{sf} = Skin friction resistance of the pile

$$Q_{eb} = A_p q_p \quad (4.2)$$

- A_p = Effective area of the tip of the pile
- For a circular closed end pile = $\pi * D^2 / 4$
- $q_p = 9c_u$ = Theoretical unit tip-bearing capacity for cohesive soils
- c_u = Undrained shear strength of soil at the base

1. Skin friction of top 5` of pile should be neglected [due to loose soil at top]
2. Skin friction of bottom 2`-5` of pile should be neglected [due to induced soil at bottom]

$$Q_{sf} = A_f q_f \quad (4.3)$$

- A_f = Effective surface area of the pile
- For a circular pile = πDL [L = thickness of soil layer]
- $q_f = \alpha_1 c_u$ = Theoretical unit friction capacity [c_u = Undrained shear strength of soil layer]
- [α_1 = reduction factor, α_1 value varies from 0.3~0.5. Normally 0.45 is used. While determining capacity by AASHTO method, $\alpha_1 = 0.55$ should be used]

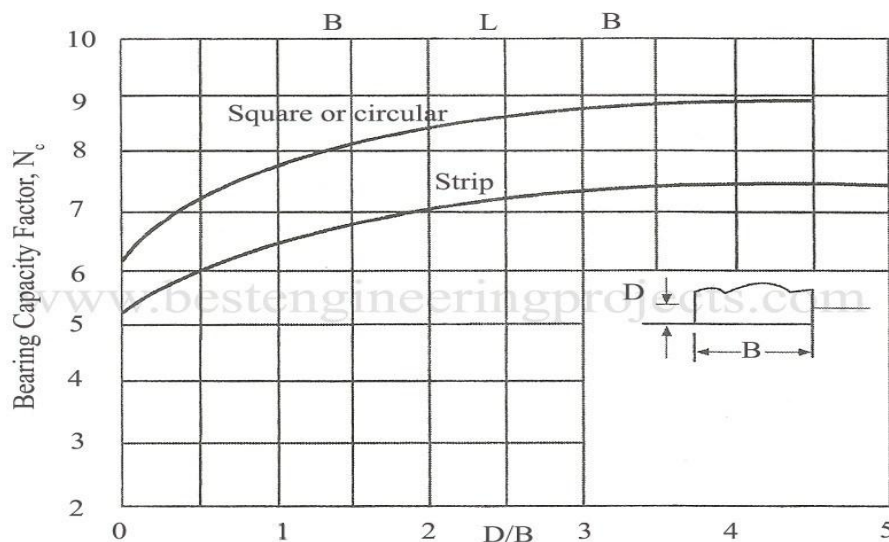

Figure 4.4: Skempton's Bearing Capacity Factor N_c

Bored Pile In Sand

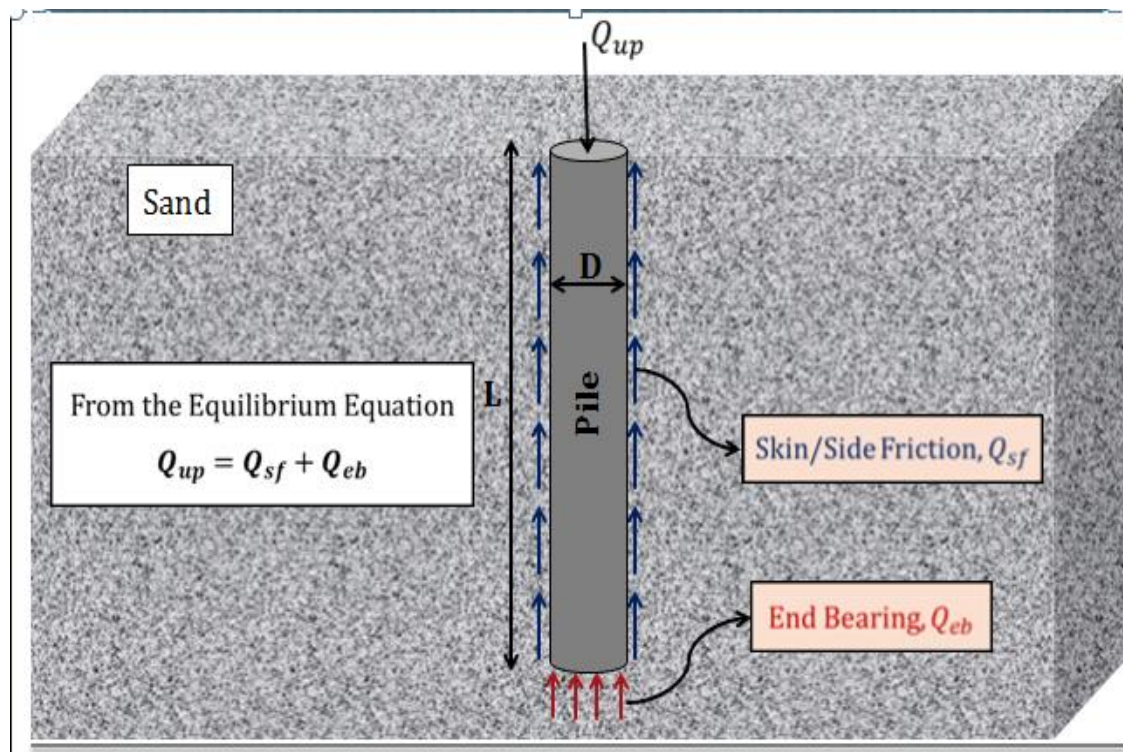

Figure 4.5: Bored Pile in Sand

$$\text{End Bearing, } Q_{eb} = 1.2 * N * A_p \quad (4.4)$$

$$\text{Skin Friction, } Q_{sf} = \beta * p_o' * A_f \quad [\beta = 1.5 - 0.135\sqrt{z}] \quad (4.5)$$

Where,

z = depth from GL to middle of the layer

N = Field N value from standard penetration test at the level of bottom

p_o' = effective overburden pressure

1. Skin friction of top 5' of pile should be neglected [due to loose soil at top]
2. Skin friction of bottom 2'-5' of pile should be neglected [due to induced soil at bottom]

Bored Pile Example In Clay

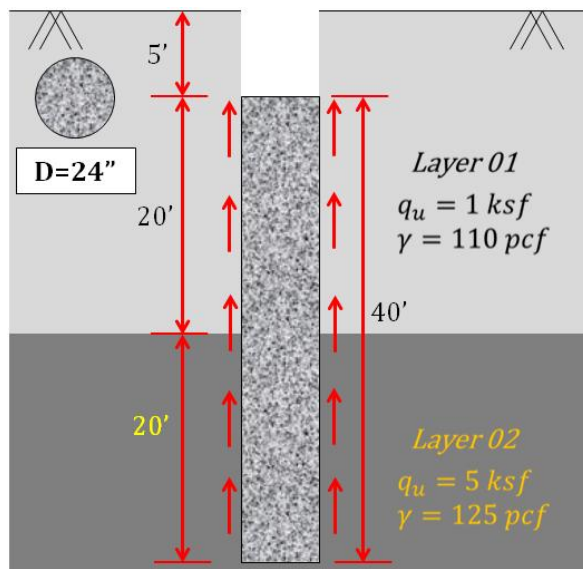

Layer 01:

$$\text{Skin Friction} = \alpha_1 c_u A_f$$

$$= 0.45 \times 0.5 \times \pi \times 2 \times 20 = 28.274 \text{ kip}$$

Layer 02:

$$\text{Skin Friction} = \alpha_1 c_u A_f$$

$$= 0.45 \times 2.5 \times \pi \times 2 \times 20 = 141.372 \text{ kip}$$

Total Skin Friction

$$= (28.274 + 141.372) = 169.646 \text{ kip}$$

Total End Bearing = $9c_u A_p$

$$= 9 \times 2.5 \times \frac{\pi}{4} \times 2^2 = 70.6858 \text{ kip}$$

Total Ult. Capacity,

$$Q_{up} = (169.646 + 70.6858) \text{ kip}$$

$$= 240.3318 \text{ kip}$$

Allowable Capacity = $\frac{Q_{up}}{F.S.}$

$$= \frac{240.3318}{2.5} = 96.13 \text{ kip}$$

Total Load on Foundation from Column = 380 kip (Assume) $\frac{D}{2} = 1 \text{ ft}$

$$\text{No. of Pile required, } N = \frac{380}{96.13} = 3.95 \approx 4$$

Inter Spacing, $S = 3D = 3 \times 2 = 6 \text{ ft}$

Face Spacing, $S = \frac{D}{2} = 1 \text{ ft}$

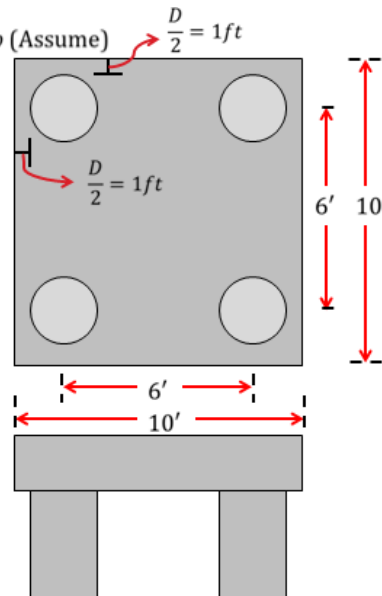

Group action

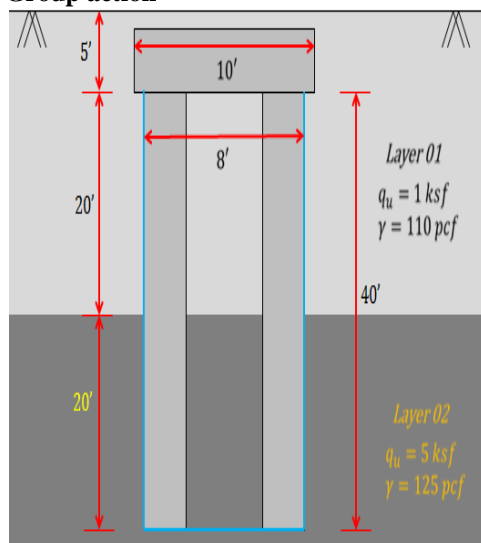

Layer 01:

$$\text{Skin friction} = \alpha_1 c_u A_f = 1 \times 0.5 \times (8 \times 20 \times 4) = 320 \text{ kip}$$

Layer 02:

$$\text{Skin friction} = \alpha_1 c_u A_f = 1 \times 2.5 \times (8 \times 20 \times 4) = 1600 \text{ kip}$$

$$\text{Total Skin Friction} = (320 + 1600) \text{ kip} = 1920 \text{ kip}$$

$$\text{Total End Bearing} = 9c_u A_p = \{9 \times 2.5 \times (8 \times 8)\} \text{ kip} = 1440 \text{ kip}$$

$$\text{Efficiency} = 80\%$$

$$\text{Total Capacity} = 0.8(1920 + 1440) \text{ kip} = 2688 \text{ kip} > 380 \text{ kip}$$

NB: Sometime Skin friction is neglected for smooth surface in group action

$$\text{Total Capacity} = 0.8(1440) \text{ kip} = 1152 \text{ kip} > 380 \text{ kip}$$

End of Bearing Capacity;
Now Settlement

Bored Pile Example In Sand

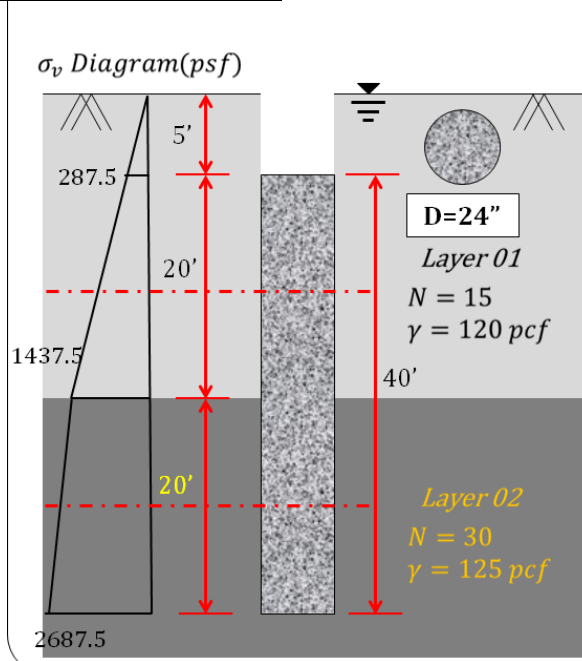

Layer 01:

$$\beta = 1.5 - 0.135\sqrt{z} = 1.5 - 0.135\sqrt{15} = 0.977$$

$$\begin{aligned} \text{Skin Friction} &= \beta \sigma_v A_f \\ &= 0.977 \times \frac{287.5 + 1437.5}{2} \times (\pi \times 2 \times 20) \\ &= 105.89 \text{ kip} \end{aligned}$$

Layer 02:

$$\beta = 1.5 - 0.135\sqrt{z} = 1.5 - 0.135\sqrt{35} = 0.701$$

$$\begin{aligned} \text{Skin Friction} &= \beta \sigma_v A_f \\ &= 0.701 \times \frac{1437.5 + 2687.5}{2} \times (\pi \times 2 \times 20) \\ &= 181.69 \text{ kip} \end{aligned}$$

$$\begin{aligned} \text{Total Skin Friction} &= (105.89 + 181.69) \\ &= 287.58 \text{ kip} \end{aligned}$$

$$\begin{aligned} \text{Total End Bearing} &= 1.2 N A_p (\text{kip}) \\ &= 1.2 \times 30 \times \frac{\pi}{4} \times 2^2 \\ &= 113.1 \text{ kip} \end{aligned}$$

Total Ult. Capacity,

$$Q_{up} = (287.58 + 113.1) \text{ kip} = 400.68 \text{ kip}$$

$$\begin{aligned} \text{Allowable Capacity} &= \frac{Q_{up}}{F.S.} \\ &= \frac{400.68}{2.5} = 160.272 \text{ kip} \end{aligned}$$

Total Load on Foundation from Column = 630 kip (Assume)

$$\text{No. of Pile required, } N = \frac{630}{160.272} = 3.93 \approx 4$$

$$\text{Inter Spacing, } S = 3D = 3 \times 2 = 6 \text{ ft}$$

$$\text{Face Spacing, } S = \frac{D}{2} = 1 \text{ ft}$$

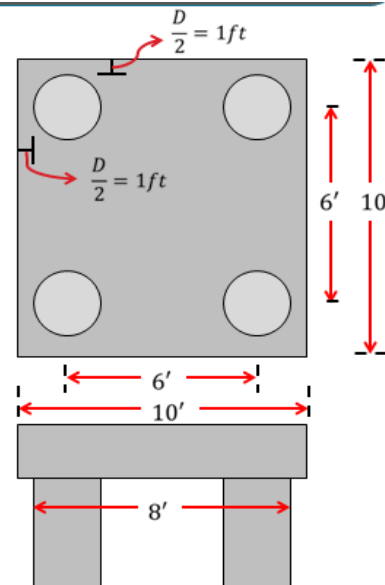

Group action

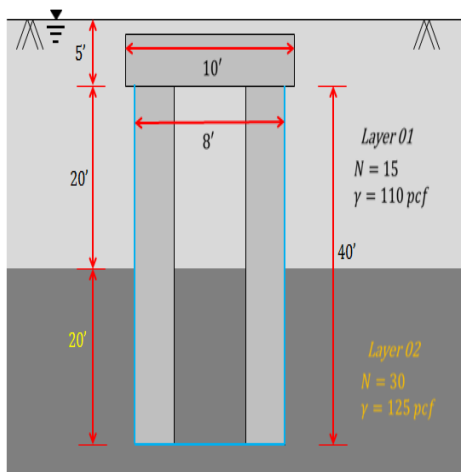

Layer 01:

$$\beta = 1.5 - 0.135\sqrt{z} = 1.5 - 0.135\sqrt{15} = 0.977$$

$$\text{Skin friction} = \beta \sigma_v A_f = 0.977 \times \frac{287.5 + 1437.5}{2} \times (8 \times 20 \times 4) = 539.304 \text{ kip}$$

Layer 02:

$$\beta = 1.5 - 0.135\sqrt{z} = 1.5 - 0.135\sqrt{35} = 0.701$$

$$\text{Skin friction} = \beta \sigma_v A_f = 0.701 \times \frac{1437.5 + 2687.5}{2} \times (8 \times 20 \times 4) = 925.32 \text{ kip}$$

$$\text{Total Skin Friction} = (539.304 + 925.32) \text{ kip} = 1464.624 \text{ kip}$$

$$\text{Total End Bearing} = 1.2 N A_p (\text{kip}) = 1.2 \times 30 \times (8 \times 8) = 2304 \text{ kip}$$

Efficiency = 80%

$$\text{Total Capacity} = 0.8(1464.624 + 2304) \text{ kip} = 3014.899 \text{ kip} > 680 \text{ kip}$$

NB: Sometime Skin friction is neglected for smooth surface in group action

$$\text{Total Capacity} = 0.8(2304) \text{ kip} = 1843.2 \text{ kip} > 680 \text{ kip}$$

End of Bearing Capacity; No need for Settlement Calculation for Sand

Special Case

Negative Skin Friction

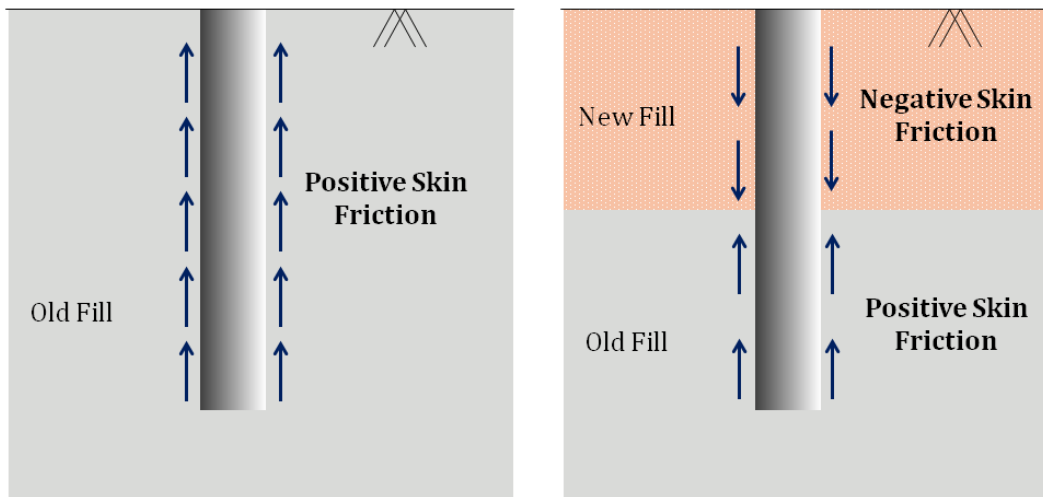

Figure 4.5: Negative Skin Friction

Determination of Pile Cap Capacity

In Clay Soil

Pile	Dia. D (ft)	Length L (ft)	c_u (ksf)	$q_f = \alpha_1 c_u$ (ksf)	$A_f = \pi DL$ (kip)	$Q_{sf} = A_f q_f$ (kip)	$Q_{eb} = 9 * c_u * A_p$ (kip)	$Q_{up} = Q_{sf} + Q_{eb}$ (kip)

Column	Load, P (kip)	Q_{up} (kip)	No. of pile reqd. (rounded), P/Q_{up}	Pile group length, (ft)	Pile Group Width (ft)	Group action Capacity of Pile cap	Individual action capacity of pile cap	Remarks

In Sandy Soil

Pile	Dia. D (ft)	Length L (ft)	N (at tip level)	$Q_{eb} = 1.2 * N * A_p$ (kip)	$\beta = 1.5 - 0.135 \sqrt{z}$	$p_o' = \gamma' * z$ (ksf)	A_f (sft)	$Q_{sf} = \beta * p_o' * A_f$ (kip)	$Q_{up} = Q_{sf} + Q_{eb}$ (kip)

Column	Load, P (kip)	Q_{up} (kip)	No. of pile reqd. (rounded), P/Q_{up}	Pile group length, (ft)	Pile Group Width (ft)	Group action Capacity of Pile cap	Individual action capacity of pile cap	Remarks

CHAPTER 5

BEARING CAPACITY

OF MAT FOUNDATION

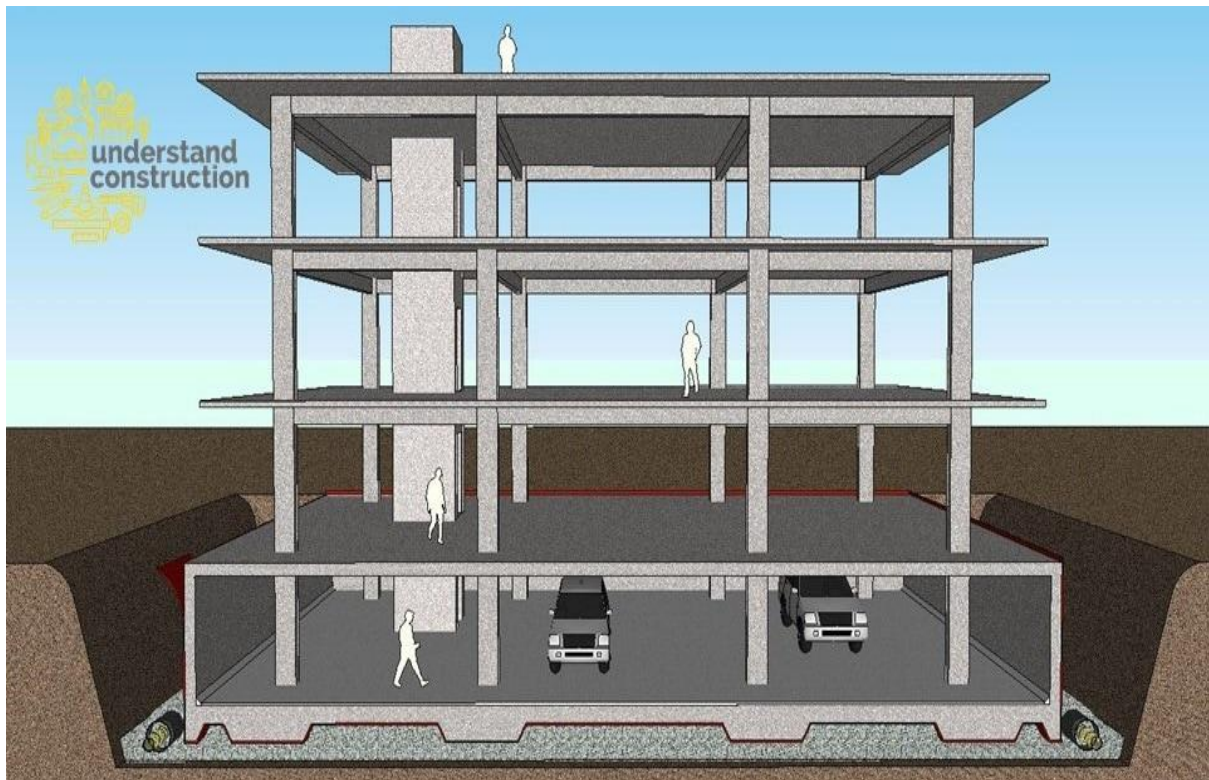

Determination of Depth D_f

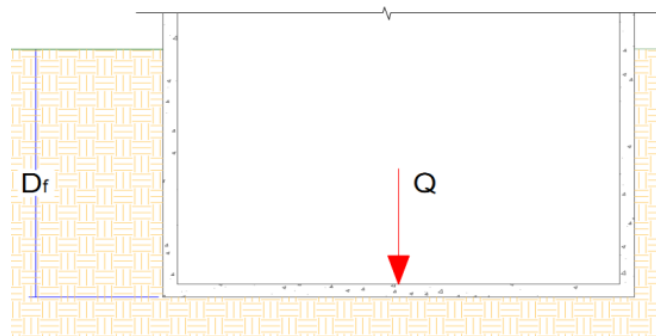

The net soil pressure q under the mat is the load from the building Q over the entire mat, minus the weight of the soil excavated $D_f\gamma$.

$$q = \frac{Q}{A} - D_f\gamma \quad (5.1)$$

When the mat is fully compensated, the weight of the soil excavated is equal to the weight of the newly imposed building Q , in other words $q=0$ and therefore

$$D_f = \frac{Q}{A\gamma} \quad (5.2)$$

Determination of Bearing Capacity

Mat on Clay

Mat foundations in purely cohesive soils have the following ultimate bearing capacity:

$$q_{ult(net)} = 5.14 c_u \left(1 + \frac{0.195B}{L}\right) \left(1 + \frac{0.4D_f}{B}\right) \quad (5.3)$$

Here,

- C_u = Undrained cohesion of soil
- B = Width of the building
- L = Length of building
- D_f = Depth of mat foundation

Mat on Sand

The allowable bearing capacity of a mat foundation in granular soils was proposed by Meyerhof (with a Factor of Safety of 3) to be based on the SPT corrected to a 55% efficiency as,

$$q_{net(all)} = \frac{N_{60}}{0.08} \left[1 + \frac{0.33D_f}{B}\right] \left[\frac{\Delta Sc}{25.4mm}\right] \leq 16.63 N_{60} \left[\frac{\Delta Sc}{25.4mm}\right] \quad (5.4)$$

Here,

- N_{60} = corrected standard penetration number
- B = Width of the building
- D_f = Depth of mat foundation
- ΔSc = Allowable settlement for mat foundation

Problem 5.1: The mat shown below is 30 m wide by 40 m long. The live and dead load on the mat is 200 MN. Find the depth D_f for a fully compensated foundation placed upon a soft clay with a unit weight $\gamma = 18.75 \text{ kN/m}^3$.

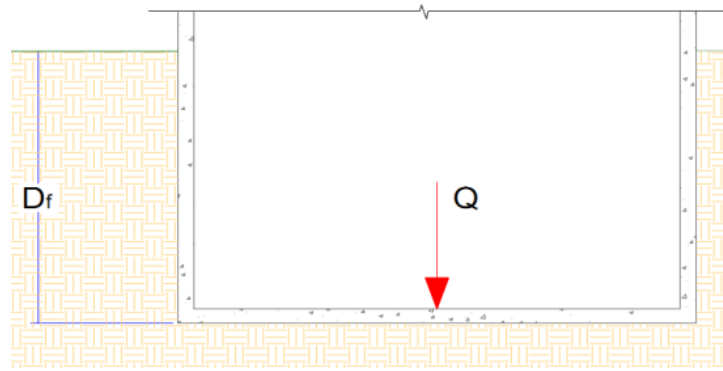

Solution:

For fully compensated condition,

$$D_f = \frac{Q}{A\gamma} = \frac{200 \times 10^3}{(30 \times 40) \times 18.75} \times 9 \text{ m} = 8 \text{ m}$$

Problem 2

Determine the ultimate bearing capacity of a mat foundation measuring 70 feet long by 50 feet wide placed 8.5 feet below the surface and resting upon a saturated clay stratum with $c_u = 1,950 \text{ lb/ft}^2$ and $\phi = 0^\circ$.

Solution:

$$q_{\text{ult(net)}} = 5.14 c_u \left(1 + \frac{0.195B}{L}\right) \left(1 + \frac{0.4D_f}{B}\right)$$

$$= 5.14 * 1.95 * \left(1 + \frac{0.195 * 50}{70}\right) * \left(1 + \frac{0.4 * 8.5}{50}\right) = 22.13 \text{ ksf}$$

Problem 3

What will be the net allowable bearing capacity of a mat foundation 15 m long by 10 m wide, embedded 2 m into a dry sand stratum with a corrected SPT to 60% efficiency $N_{60} = 10$. It is desired that the allowable settlement is $\Delta S_c = 30 \text{ mm}$.

Solution:

$$q_{\text{net(all)}} = \frac{N_{60}}{0.08} \left[1 + \frac{0.33D_f}{B}\right] \left[\frac{\Delta S_c}{25.4 \text{ mm}}\right] \leq 16.63 N_{60} \left[\frac{\Delta S_c}{25.4 \text{ mm}}\right]$$

$$= \frac{10}{0.08} * \left[1 + \frac{0.33 * 2}{10}\right] \left[\frac{30 \text{ mm}}{25.4 \text{ mm}}\right] = k/\text{m}^2$$

Again,

$$16.63 N_{60} \left[\frac{\Delta S_c}{25.4 \text{ mm}}\right]$$

$$= 16.63 * 10 \left[\frac{30 \text{ mm}}{25.4 \text{ mm}}\right] =$$

So,

$$q_{\text{net(all)}} = 196.42 \text{ kN/m}^2$$

CHAPTER 6

SOIL SETTLEMENT

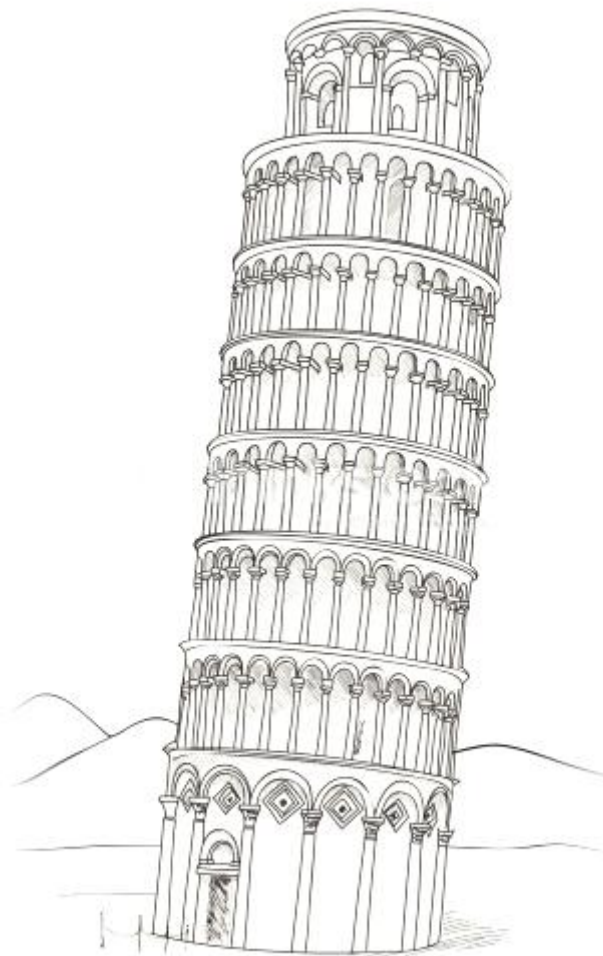

A soil shear failure can result in excessive building distortion and even collapse. Excessive settlements can result in structural damage to a building frame nuisances such as sticking doors and windows, cracks in tile and plaster, and excessive wear or equipment failure from misalignment resulting from foundation settlements.

It is necessary to investigate both base shear resistance (ultimate bearing capacity) and settlements for any structure. In many cases settlement criteria will control the allowable bearing capacity.

Except for occasional happy coincidences, soil settlement computations are only best estimates of the deformation to expect when a load is applied.

The components of settlement of a foundation are:

1. Immediate settlement
2. Consolidation Settlement, and
3. Secondary compression (creep)

$$\Delta H = \Delta H_i + U \Delta H_c + \Delta H_s \quad (6.1)$$

ΔH = total settlement, ΔH_c = consolidation settlement, ΔH_s = secondary compression, U = average degree of consolidation. Generally, the final settlement of a foundation is of interest and U is considered equal to 1 (i.e. 100% consolidation)

1. Immediate Settlement

Immediate settlement concerns the initial pressure on the soil under and surrounding the foundation. It is "immediate" because it occurs during and right after construction. It has nothing to do with water displacement, but is merely caused by the weight of the structure. In terms of building foundations, immediate settlement is relatively easy to predict and measure. In many cases, given the nature of the soil, foundations are constructed with the ability to withstand a certain amount of shift without damage. Damage usually occurs only in the long term, as the shift slowly continues over time.

- Immediate settlement takes place as the load is applied or within a time period of about 7 days.
- Predominates in cohesion less soils and unsaturated clay
- Immediate settlement analysis are used for all fine-grained soils including silts and clays with a degree of saturation < 90% and for all coarse grained soils with large co-efficient of permeability (say above 10.2 m/s)

2. Consolidation Settlement (ΔH_c)

Consolidation settlement is distinguished from immediate settlement both by the duration of the settlement and by displacement of water. Consolidation is the more worrisome form of settlement because it is difficult to predict over months or years. Consolidation settlement is the settling of a foundation, over time, due to pressure exerted by the structure and squeezes out the water content of the soil, thus compressing it. Expulsion of moisture from the soil usually is a long-term process.

- Consolidation settlements are time dependent and take months to years to develop. The leaning tower of Pisa in Italy has been undergoing consolidation settlement for over 700 years. The lean is caused by consolidation settlement being greater on one side. This, however, is an extreme case. The principal settlements for most projects occur in 3 to 10 years.
- Dominates in saturated/nearly saturated fine grained soils where consolidation theory applies. Here we are interested to estimate both consolidation settlement and how long a time it will take or most of the settlement to occur.

3. Secondary Settlement/Creep (ΔH_c)

Consolidation settlement has two components, primary and secondary. The former deals explicitly with the settlement caused by soil moisture displacement, and the latter deals with the elastic settlement after all movable water has been squeezed out of the soil. Primary consolidation is the most significant and potentially harmful of the two. Primary consolidation takes quite a bit of time, from weeks to years. Secondary consolidation is the quicker result of primary consolidation. Once primary has been completed, and all movable water has been moved, secondary kicks in. Secondary consolidation occurs immediately after primary, and takes far less time to complete. After secondary consolidation is complete, the structure remains in its permanent position. As a result, many builders advise residents in new homes to avoid repairing any settlement damage until secondary consolidation is complete, which is normally after two years at most.

- Occurs under constant effective stress due to continuous rearrangement of clay particles into a more stable configuration.
- Predominates in highly plastic clays and organic clays.

Immediate settlement computation

$$\Delta H_i = q_0 B \frac{1 - \mu^2}{E_s} m I_s I_E \quad (6.2)$$

Where

q_0 = intensity of contact pressure in units of E_s (Undrained Modulus of Elasticity)

B' = least lateral dimension of contributing base area in units of ΔH_i

E_s, μ = Elastic Soil Parameters. A major problem is of course to obtain correct stress-strain modulus E_s . E_s can be found from laboratory tests like unconfined compression tests,

Triaxial compression tests, and in-situ tests like SPT, CPT, Plate load tests, Pressure meter etc

m = number of corners contributing to settlement ΔH_i . At the footing center $m=4$; and at a corner $m=1$, at a side $m=2$.

I_E = Embedment reduction factor, which suggests that the settlement is reduced when it is placed at some depth in the ground. For surface footing $I_E = 1$

I_s = Influence Factor

$$I_s = I_1 + \frac{1 - 2\mu}{1 - \mu} I_2 \quad (6.3)$$

The above equation for I_s is strictly applicable to flexible bases on the half space. In practice, most foundations are flexible because even every thick footing deflects when loaded by superstructure load. If the base is rigid, reduce I_s factor by about 7%. The half space may consist of either cohesion less material or any water content, or unsaturated cohesive soils.

Secondary compression/creep

After primary consolidation the soil structure continues to adjust to the load for some additional time. This settlement is termed secondary consolidation/secondary compression. At the end of secondary consolidation the soil has reached a new K_0 -state (at-rest state).

Secondary consolidation may be the larger component if settlement in some soils, particularly in soils with a large organic component. Secondary consolidation is associated with both immediate & consolidation type settlements, although it is usually not of much significance with immediate settlements. The magnitude of secondary compression for a given time is generally greater for NCC than for OCC.

The rate of secondary compression J in the consolidation (oedometer) test can be defined by the slope C_α of the final part of the compression/log time curve. Where H_{sl} = thickness of the laboratory sample at time t_1 , ΔH_{sl} = Change in sample thickness of soil sample between t_1 and t_2 .

To find secondary consolidation settlement in the field (ΔH_s),

$$\Delta H_s = \Delta C_\alpha \log \frac{t_{100(f)} + \Delta t}{t_{100(f)}} \quad (6.4)$$

H = Thickness of the field consolidating stratum at the end of primary consolidation. Commonly initial thickness is used unless the primary consolidation is very large. Say more than 10% of initial thickness.

$t_{100(f)}$ = time taken for primary consolidation to complete in the field

Δt = time interval beyond $t_{100(f)}$

$t_2 = t_{100(f)} + \Delta t$ = time for which secondary settlement is to be calculated.

To find $t_{100(f)}$ following relationship is used

$$\frac{t_{100(f)}}{d_f^2} = \frac{t_{100(lab)}}{d_{lab}^2} \quad (6.5)$$

Where $t_{100(lab)}$ and $t_{100(f)}$ = time taken for primary consolidation to complete in the laboratory d_f , d_{lab} = are respectively maximum drainage paths in the field and laboratory. For one-way drainage d = thickness of the layer of interest or sample thickness in the laboratory, for two-way drainage d = half of the thickness of the layer of interest/sample.

Settlement Limits

Total settlement is the magnitude of downward movement. Differential settlement is non-uniform settlement. It is "the difference of settlement between various locations of the structure. Angular distortion between two points under a structure is equal, to the differential settlement between the points divided by the distance between them. Theoretically speaking, no damage will be done to a structure if it settles uniformly as a whole regardless of how large the settlement may be. The only damage would be to the connections of the underground utility lines. However, when the settlement is non-uniform (differential), as is always the case, damage may be caused to the structure. The tolerable, settlements of different structures, vary considerably. Simple-span frames can take considerably greater distortion than rigid frames. A fixed-end arch would suffer greatly if the abutments settle or rotate. For road embankments, storage silos and tanks a settlement of 300mm - 600mm may be acceptable, but for machine foundations the settlement may be limited to 5mm 30mm. Different types of construction materials can withstand different degrees of distortion. For example, sheet metal wall panels do not show distress as readily as brick masonry.

To reduce differential settlement, the designer may limit the total settlement and use the following equation for the calculation of the differential settlement:

$$(\Delta H_{diff})_{max} = \frac{1}{2} \Delta H_{total} \quad (6.6)$$

uidelines to limiting values are suggested by a number of sources, but following routine limits appear to be conventionally acceptable (Skempton and Mac Donald, 1956)

Skempton and MacDonald suggested the following permissible settlements

SANDS

Maximum total settlement = 40 mm for isolated footing
= 40 – 65 mm for rafts.
Maximum differential settlement = 25 mm between adjacent columns.

CLAYS

Maximum total settlement = 65 mm for isolated footing
= 65 – 100 mm for rafts.
Maximum differential settlement = 40 mm between adjacent columns.

The differential settlement may also be evaluated in terms of the angular distortion given by:

$$(\Delta H_{diff}) = \Delta/L \quad (6.7)$$

Where

Δ = relative settlement between the two points and

L = Horizontal distance between the two points.

Based on a large number of settlement observations and performance of structures, the suggested limits for tolerable differential settlements are show in table below.

Table 6.1: Tolerable differential settlements

Angular distortion	Type of limit and structure
1/150	Structure damage of general buildings expected
1/250	Tilting of high rigid buildings may be visible
1/300	Cracking in panel walls expected Difficulties with overhead cranes
1/500	Limit for buildings in which cracking is not permissible
1/600	Overstressing of structural frames with diagonals
1/750	Difficulty with machinery sensitive to settlement

Consolidation Settlement Calculation

Problem 6.1: If the soil is clayey soil, calculate the consolidation settlement and check the differential settlement for the columns.

Solution:

Estimation of Consolidation Settlement of Clay Soils

One dimensional consolidation test results:

(Used for estimating total consolidation settlement)

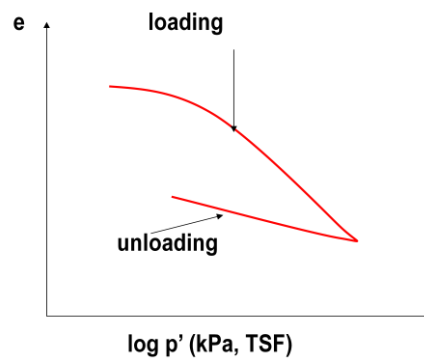

Normally consolidated clay: whose present effective overburden pressure is the maximum pressure that the soil was subjected to in the past.

Overconsolidated clay: whose present effective overburden pressure is less than that which the soil experienced in the past.

Pre-consolidation pressure is the maximum effective past pressure.

Normally consolidated clay: $p'_o = p_c'$

Over consolidated clay: $p'_o < p_c'$, $OCR = p_c'/p'_o$

Step 1: Determination of pre consolidation pressure, p_o

1. By visual observation, establish point a, at which the e–logp plot has a minimum radius of curvature.
2. Draw a horizontal line ab.
3. Draw the line ac tangent at a.
4. Draw the line ad, which is the bisector of the angle back.
5. Project the straight-line portion gh of the e–logp plot back to intersect line ad at f. The abscissa of point f is the preconsolidation pressure, p_c .

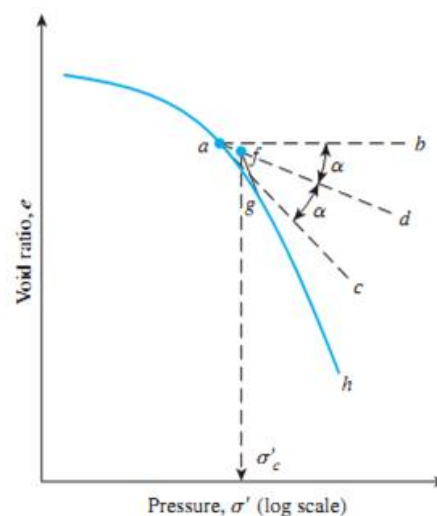

Figure 6.1: e-log P curve

Step 2: Calculation of Consolidation settlement

P_c

For Normally consolidated clay:

$$S_c = \frac{C_c H}{(1+e_o)} \log_{10} \frac{p_o + \Delta P}{p_o}$$

Here,

C_c = Compressibility Index

H = Height of clay layer (from footing bed to mid height of clay layer)

e_o = Initial void ratio

p_o = Effective overburden pressure, $p_o = \gamma h$

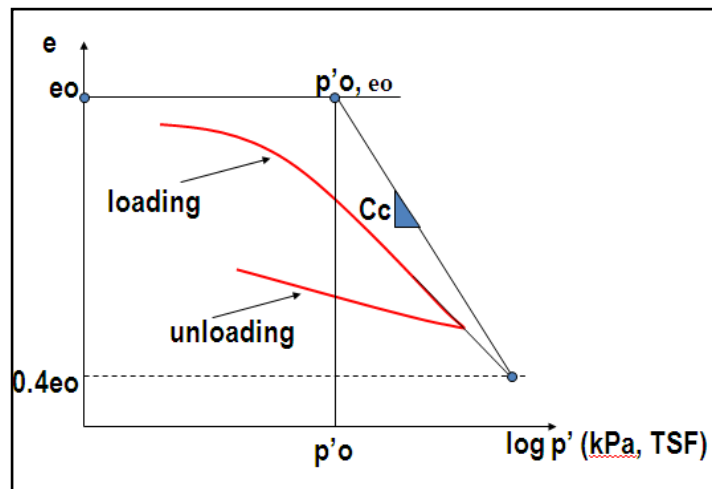

Figure 6.2: Field consolidation line for normally consolidated clay

$$h = D_f + H$$

$$\Delta P = \text{Additional pressure due to structure} \Delta P = \frac{\text{Load}}{(B+H)^2}$$

For Over consolidated clay:

Case 1: $(p_o + \Delta p) \leq p_c$:

$$S_c = \frac{C_s H}{(1+e_o)} \log_{10} \frac{p_o + \Delta P}{p_o}$$

Case 2: $(p_o + \Delta p) > p_c$:

$$S_c = \frac{C_s H}{(1+e_o)} \log_{10} \frac{p_c}{p_o} + \frac{C_c H}{(1+e_o)} \log_{10} \frac{p_o + \Delta P}{p_c}$$

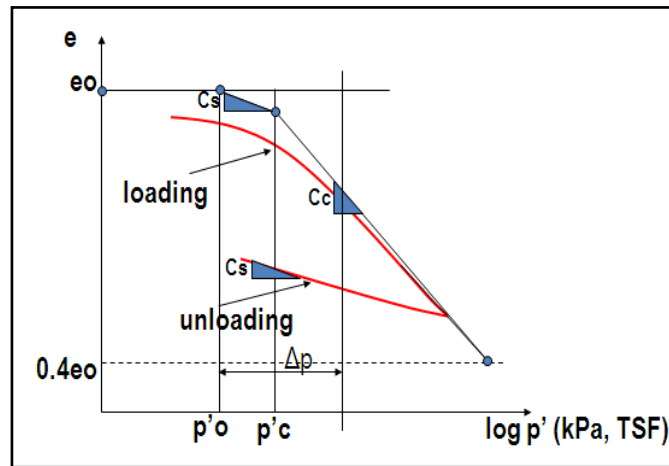

Figure 6.2: Field consolidation line for over consolidated clay

Definition of H for infinite depth of clay layer:

Solution of the equation:

$$P/(B+H)^2 = 0.2 \cdot P/B^2$$

Gives:

$$H \approx 1.25B$$

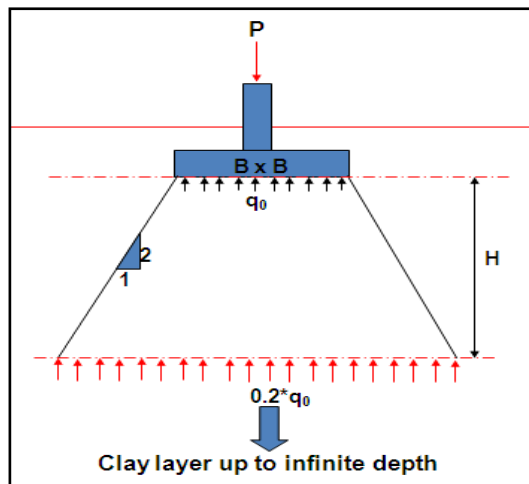

Settlement for Shallow Foundation

Consolidation settlement data sheet

Initial void ratio, $e_0 =$

Pre-consolidation pressure, $p_c =$

Compressibility index, $C_c =$

Swelling index, $C_s =$

Column	Depth of Foundation D_f	Width of footing B	Load from structure	Height of clay layer H	Additional pressure due to structure. $\Delta P = \frac{Load}{(B+H)^2}$	Effective overburden pressure $P_o = \gamma H$	Consolidation Type	C_c	C_s	Consolidation Settlement S_c

Step 3: Check Angular Rotation for differential settlement

Differential settlement for two columns C_1 and C_2 :

$$\Delta S = S_c C_1 - S_c C_2$$

Angular rotation:

$$\frac{\Delta S}{L} \quad (L = \text{center to center distance between two columns})$$

$$\frac{\Delta S}{L} > \frac{1}{300} = \text{OK}$$

$$\frac{\Delta S}{L} < \frac{1}{300} = \text{Not OK}$$

Angular Rotation Check data sheet:

Considered Columns	Corresponding span, L	Differential settlement, ΔS	Angular rotation $\frac{\Delta S}{L}$	Check $\frac{\Delta S}{L} < \frac{1}{300} = \text{OK}$

* For each column differential settlement of nearest two columns should be checked.

SETTLEMENT FOR BORED PILE

Example: Calculate the settlement of the bored pile given below.

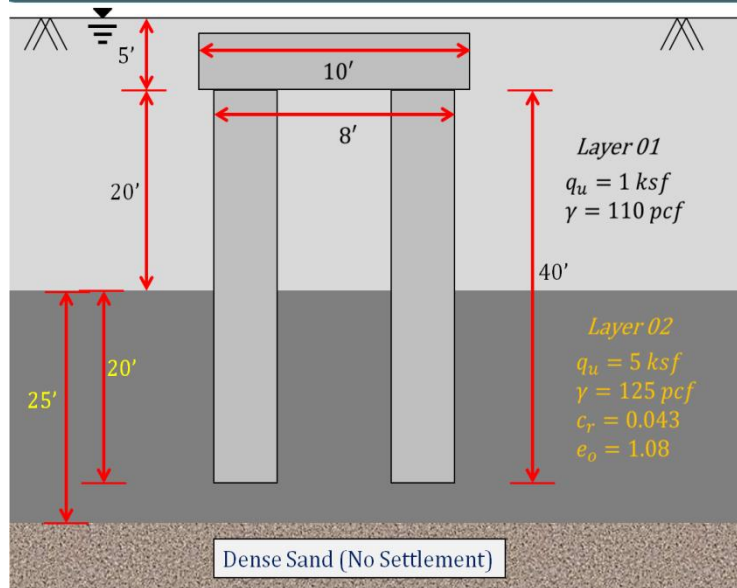

Solution:

$$P_o = \sum \gamma' h$$

upto mid layer of 18.33' zone

$$= 25 \times (110 - 62.5)$$

$$+ \left(6.67 + \frac{18.33}{2} \right) (125 - 62.5)$$

$$= 2177.1875 \text{ psf}$$

$$\Delta P = \frac{380 \times 1000}{\left(8 + \frac{18.33}{2} \right)^2} = 1289.72 \text{ psf}$$

$$H_c = 18.33 \text{ ft}$$

$$S = \frac{c_r H_c}{1 + e_o} \log \left(\frac{P_o + \Delta P}{P_o} \right)$$

$$= \frac{0.043 \times 18.33 \times 12}{1 + 1.08} \log \left(\frac{2177.1875 + 1289.72}{2177.1875} \right)$$

$$= 0.92 \text{ inch} < \mathbf{2 \text{ inch}}$$

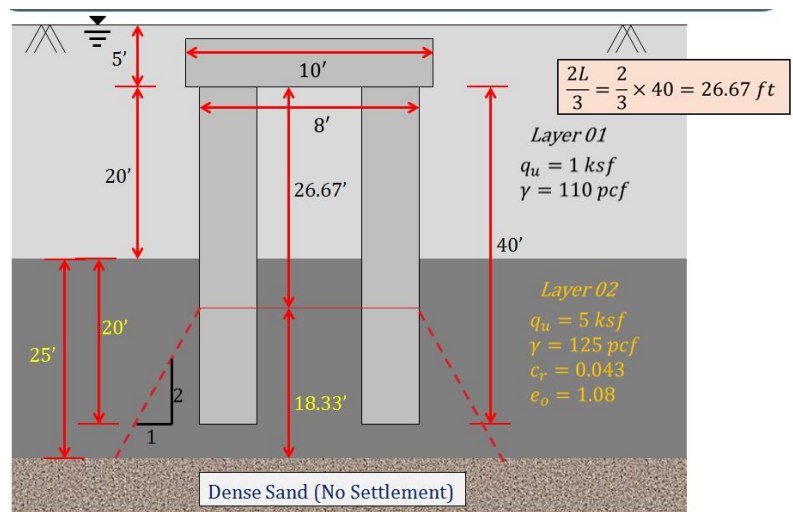

NB: If $S > 2"$, Greater depth should be provided but then required no. of pile may reduce in respect of bearing capacity

SETTLEMENT OF MAT FOOTING

- ❑ Basically same as individual footing (Single Footing), difference is in individual footing we have calculated one settlement but in mat footing we have to calculate two settlement
 1. Settlement in corner
 2. Settlement in center
- ❑ As individual footing is generally small in size, so its settlement in corner and settlement in center is almost equal. So we have calculated it in one time
- ❑ In mat footing, as it is large in size, their settlement in corner and center varies. So we have to calculate two settlements. For this variable settlement in corner and center extra stress develops. So we can't neglect it.

$$S = \frac{C_c H_c}{1 + e_o} \log \left(\frac{P_o + \Delta P}{P_o} \right)$$

Increase in vertical stress (ΔP) is found by -----

- ❖ **2:1 Method** : Used for individual footing and Pile foundation
- ❖ **Empherical Formula** : Used for Mat Footing
- ❖ **Fadum Chart** : Used for Mat Footing
- ❖ **Newmark's Influence Chart** : Used for Mat Footing **etc.**

For Mat Foundation

- ❖ Empherical Formula
- ❖ Fadum Chart
- ❖ Newmark's Influence Chart etc.

Note 1:

For **Empherical Formula** and **Fadum Chart** we can only determine the **increase in vertical stress (ΔP)** at corner; so if we have to determine ΔP at other point then we have to make it corner.

Example:

Determine ΔP at denoted point

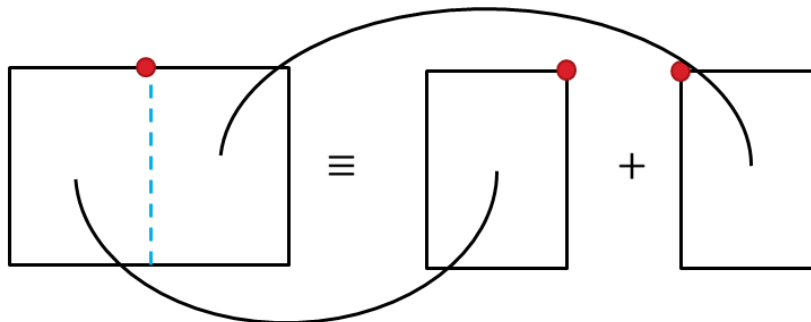

Example:
Determine ΔP at denoted point

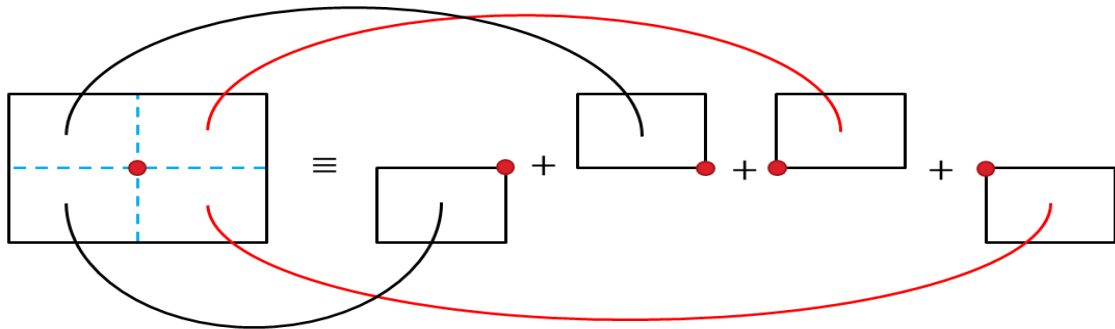

Note 2:
For **Empherical Formula** and **Fadum Chart**

$$m = \frac{x}{z}$$

$$n = \frac{y}{z}$$

or

$$m = \frac{y}{z}$$

$$n = \frac{x}{z}$$

$$\Delta P = q_o \times I$$

$$q_o = q - \gamma D_f$$

$$q = \frac{P}{L \times B}$$

$$I = f(m, n)$$

Empherical Formula

$$m = \frac{x}{z}$$

$$n = \frac{y}{z}$$

or

$$m = \frac{y}{z}$$

$$n = \frac{x}{z}$$

$$\Delta P = q_o \times I$$

$$I = f(m, n)$$

$$I = \frac{1}{4\pi} \left[\frac{2mn\sqrt{m^2 + n^2 + 1}}{m^2 + n^2 + m^2n^2 + 1} \left(\frac{m^2 + n^2 + 2}{m^2 + n^2 + 1} \right) + \tan^{-1} \left(\frac{2mn\sqrt{m^2 + n^2 + 1}}{m^2 + n^2 - m^2n^2 + 1} \right) \right]$$

→ Radian

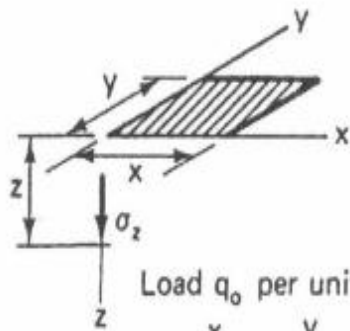

Load q_0 per unit of area

$$m = \frac{x}{z}; n = \frac{y}{z}$$

m and n are interchangeable

$$\sigma_z = q_0 I$$

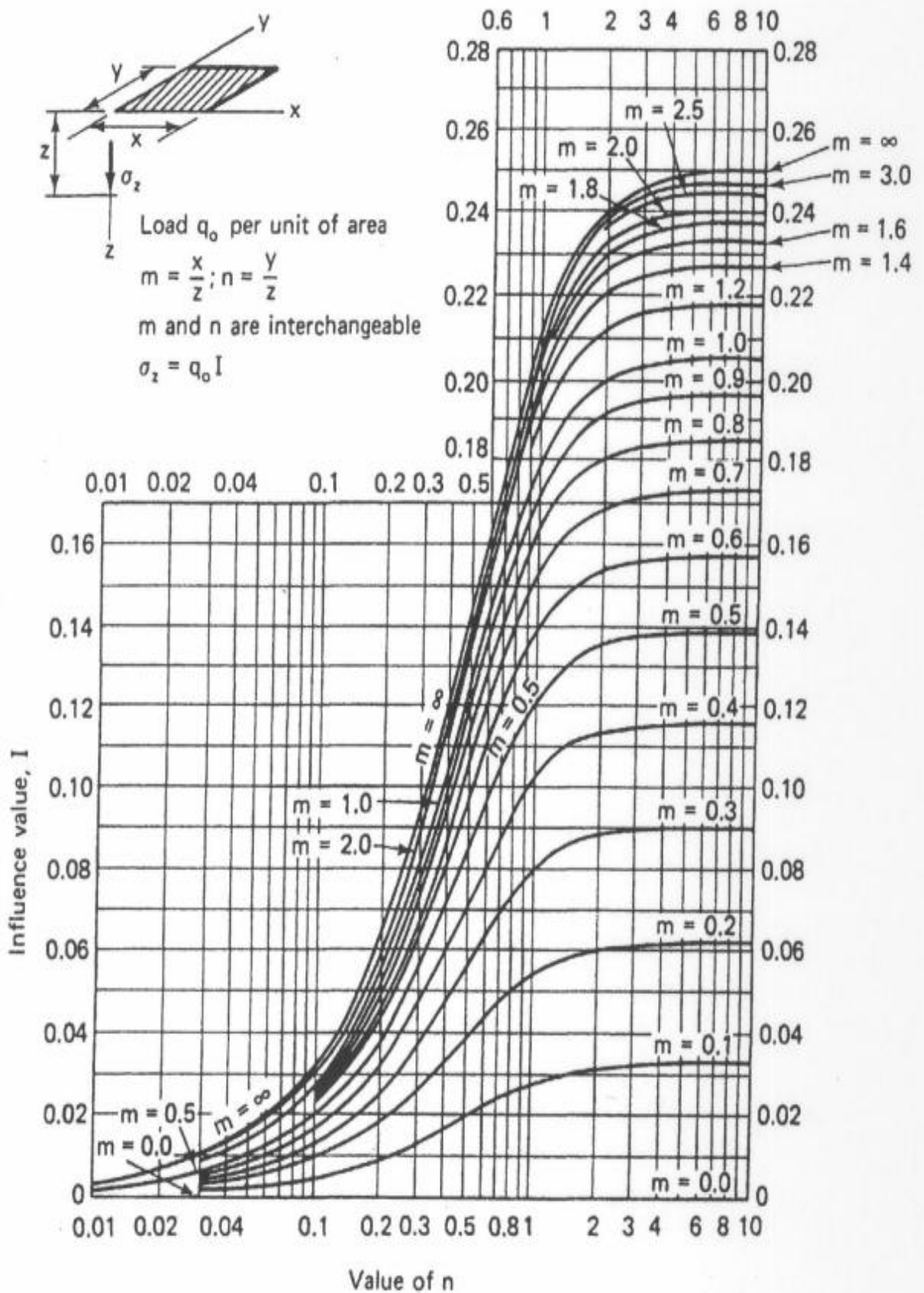

Newmark's Influence Chart

A point where ΔP is required must be at the center of the Newmark's Influence Chart

Example:

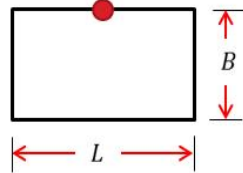

$$L = AB \text{ or } B = AB$$

$$\Delta P = q_o I N$$

$I = \text{Influence Value} = 0.005$

$N = \text{Number of blocks with in the shape}$

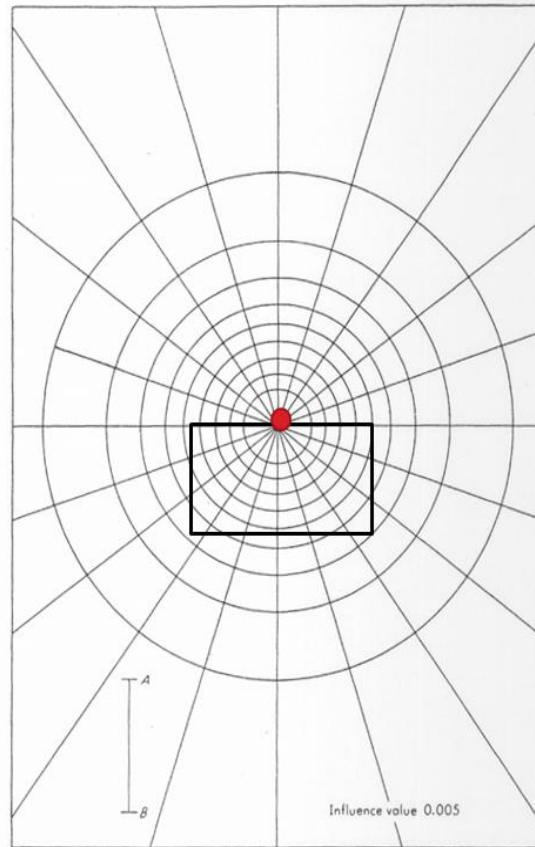

When calculating **settlement** of Mat footing, **rotation** is also determined

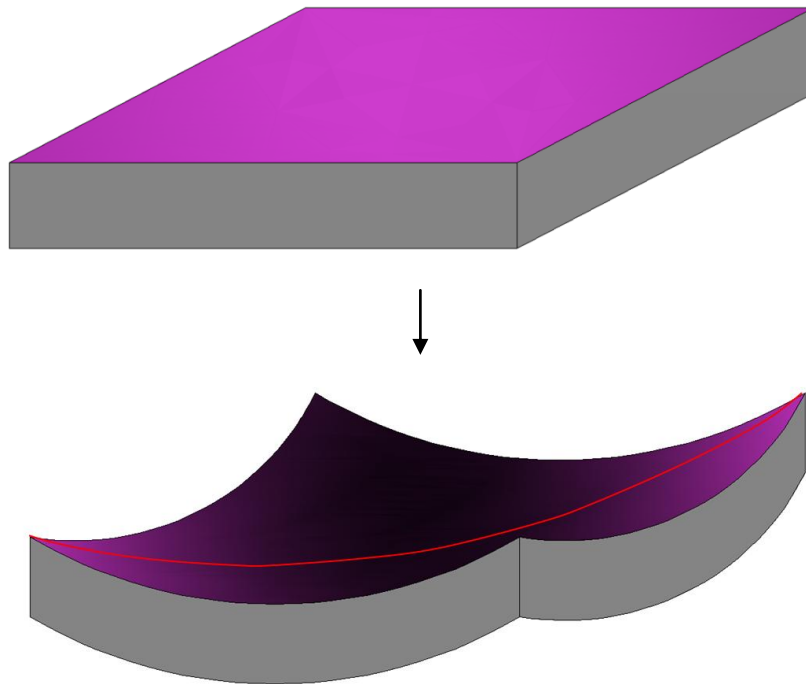

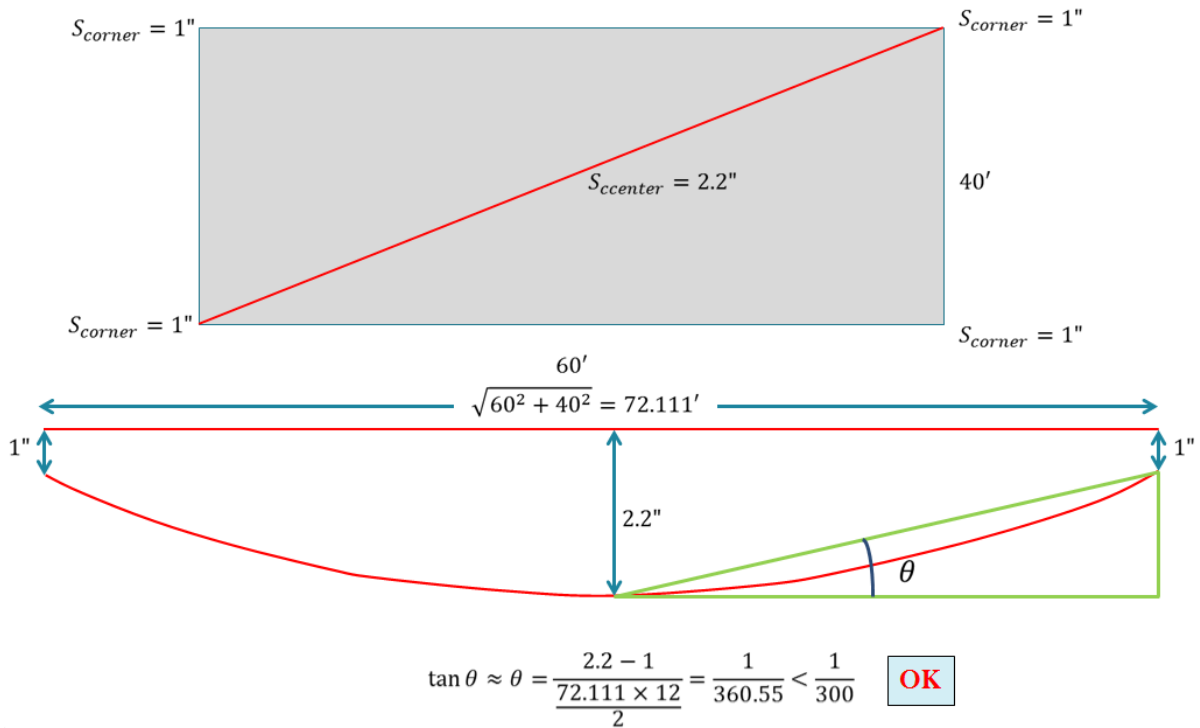

In 1956, Skempton and McDonald proposed the following limiting values for maximum settlement and maximum angular distortion, to be used for building purposes:

Maximum settlement, $S_{T(\max)}$	
In sand	32 mm
In clay	45 mm
Maximum differential settlement, $\Delta S_{T(\max)}$	
Isolated foundations in sand	51 mm
Isolated foundations in clay	76 mm
Raft in sand	51–76 mm
Raft in clay	76–127 mm
Maximum angular distortion, β_{\max}	1/300

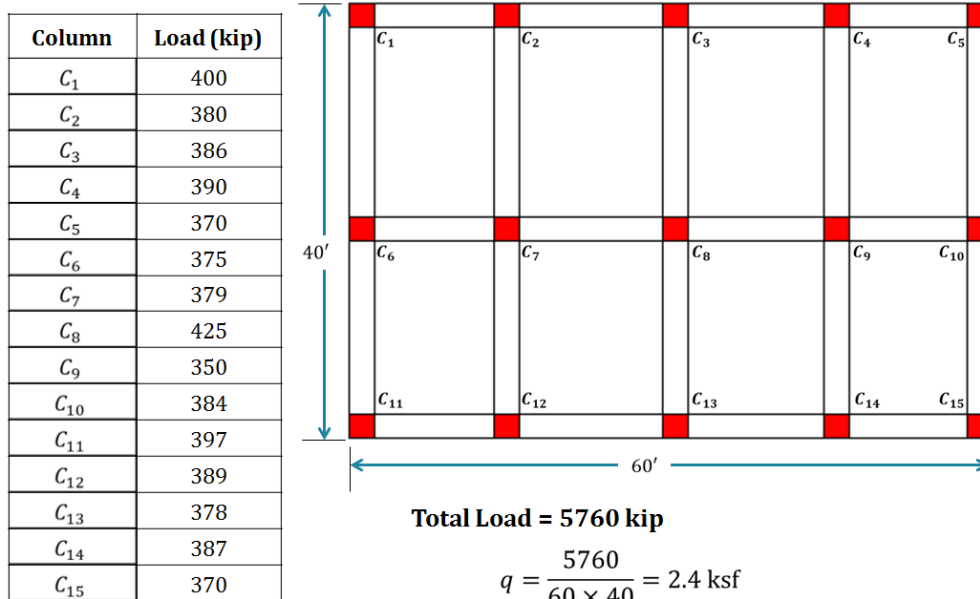

Example: Find settlement (S_{corner} & S_{center}) of Mat foundation due to 14' clay layer

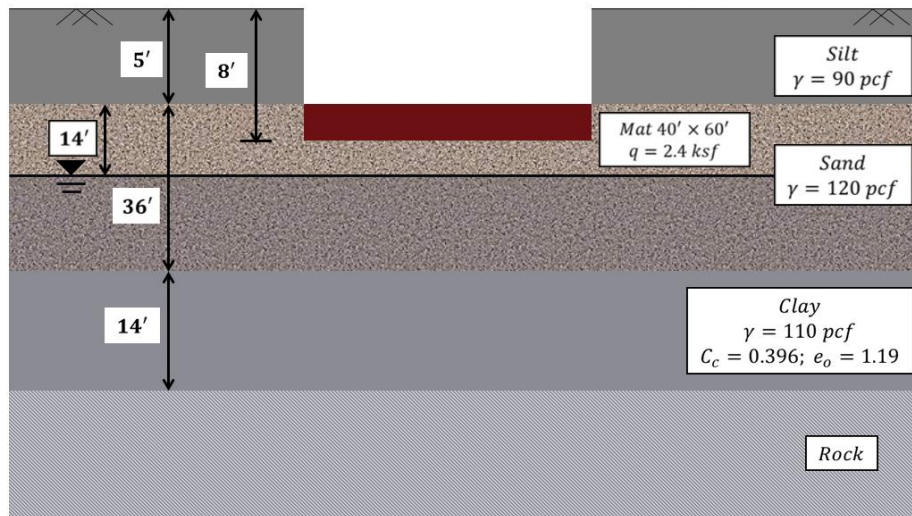

Solution:

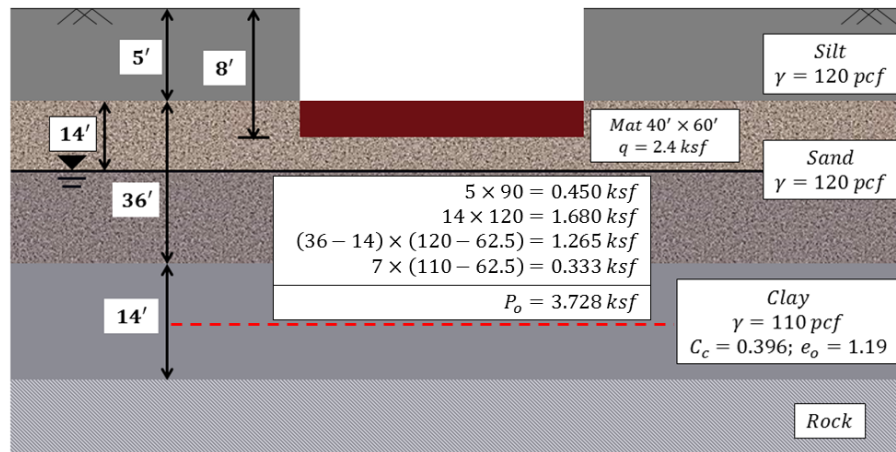

<p>Corner:</p> <div style="display: flex; align-items: center; margin-bottom: 10px;"> <div style="border: 1px solid black; padding: 2px; font-size: small;"> ΔP determination (Emperical Formula) </div> </div> <div style="display: flex; align-items: center; margin-bottom: 10px;"> <div style="margin-right: 10px;"> $m = \frac{x}{z} = \frac{60}{40} = 1.5$ $n = \frac{y}{z} = \frac{40}{40} = 1$ </div> <div style="font-size: 2em; margin-right: 10px;">}</div> <div style="color: red; font-weight: bold;">Interchangable</div> </div> <p>$z =$ distance between bottom of footing and mid clay layer</p> <p>$q = 2.4 \text{ ksf} = 2400 \text{ psf}$</p> <p>Contact Pressure, $q_o = 2400 - 5 \times 90 - 3 \times 120 = 1590 \text{ psf}$</p> <div style="border: 1px solid black; padding: 5px; margin: 10px 0; font-size: small;"> $I = \frac{1}{4\pi} \left[\frac{2mn\sqrt{m^2+n^2+1}}{m^2+n^2+m^2n^2+1} \left(\frac{m^2+n^2+2}{m^2+n^2+1} \right) + \tan^{-1} \left(\frac{2mn\sqrt{m^2+n^2+1}}{m^2+n^2-m^2n^2+1} \right) \right]$ </div> <p>$I = 0.194$</p> <p>$\Delta P = I \times q_o = 0.196 \times 1590 = 308.46 \text{ psf}$</p>	<p>Center:</p> <div style="display: flex; align-items: center; margin-bottom: 10px;"> <div style="border: 1px solid black; padding: 2px; font-size: small;"> ΔP determination (Emperical Formula) </div> </div> <div style="display: flex; align-items: center; margin-bottom: 10px;"> <div style="margin-right: 10px;"> $m = \frac{x}{z} = \frac{30}{40} = 0.75$ $n = \frac{y}{z} = \frac{20}{40} = 0.5$ </div> <div style="font-size: 2em; margin-right: 10px;">}</div> <div style="color: red; font-weight: bold;">Interchangable</div> </div> <p>$z =$ distance between bottom of footing and mid clay layer</p> <p>$q = 2.4 \text{ ksf} = 2400 \text{ psf}$</p> <p>Contact Pressure, $q_o = 2400 - 5 \times 90 - 3 \times 120 = 1590 \text{ psf}$</p> <div style="border: 1px solid black; padding: 5px; margin: 10px 0; font-size: small;"> $I = \frac{1}{4\pi} \left[\frac{2mn\sqrt{m^2+n^2+1}}{m^2+n^2+m^2n^2+1} \left(\frac{m^2+n^2+2}{m^2+n^2+1} \right) + \tan^{-1} \left(\frac{2mn\sqrt{m^2+n^2+1}}{m^2+n^2-m^2n^2+1} \right) \right]$ </div> <p>$I = 0.107$</p> <p>$\Delta P = 4I \times q_o = 4 \times 0.107 \times 1590 = 680.52 \text{ psf}$</p>
--	---

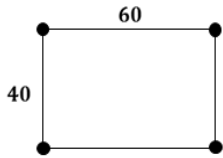

ΔP determination (Fadum Chart)

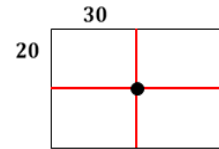

Corner:

$$m = \frac{x}{z} = \frac{60}{40} = 1.5$$

$$n = \frac{y}{z} = \frac{40}{40} = 1$$

} **Interchangeable**

z = distance between **bottom of footing** and **mid clay layer**

$q = 2.4 \text{ ksf} = 2400 \text{ psf}$

Contact Pressure,

$$q_o = 2400 - 5 \times 90 - 3 \times 120 = 1590 \text{ psf}$$

$I = 0.196$

$$\Delta P = I \times q_o = 0.196 \times 1590 = 311.64 \text{ psf}$$

Center:

$$m = \frac{x}{z} = \frac{30}{40} = 0.75$$

$$n = \frac{y}{z} = \frac{20}{40} = 0.5$$

} **Interchangeable**

z = distance between **bottom of footing** and **mid clay layer**

$q = 2.4 \text{ ksf} = 2400 \text{ psf}$

Contact Pressure,

$$q_o = 2400 - 5 \times 90 - 3 \times 120 = 1590 \text{ psf}$$

$I = 0.107$

$$\Delta P = 4I \times q_o = 4 \times 0.107 \times 1590 = 680.52 \text{ psf}$$

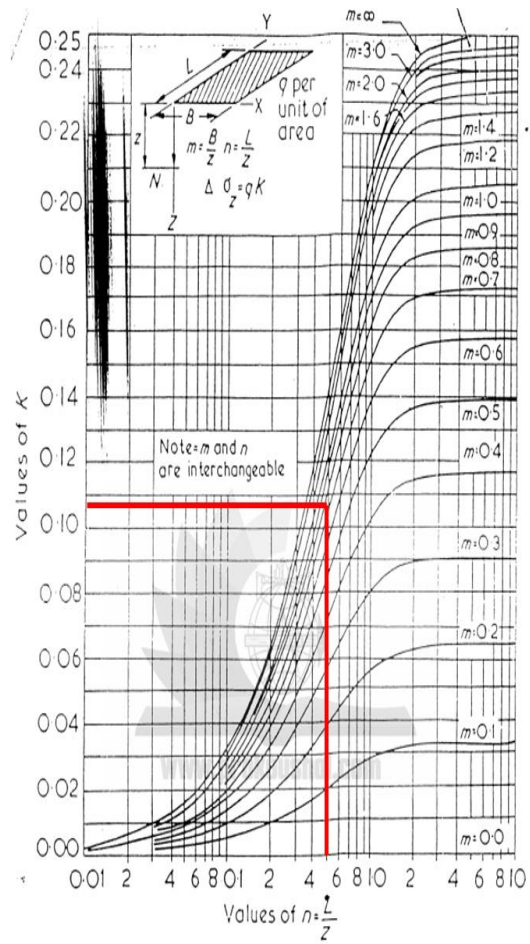
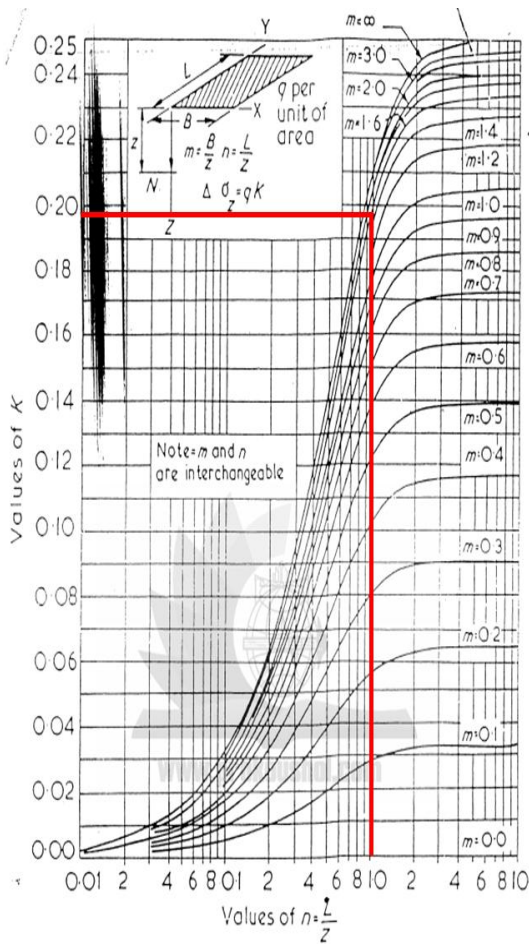

ΔP determination (Newmark's Influence Chart)

Corner:

$$AB = 60 \text{ ft}$$

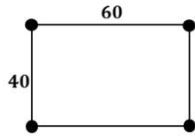

$$\Delta P = q_o I N$$

$$I = \text{Influence Value} = 0.005$$

$$N = \text{Number of Blocks within the Rectangular Area} = 38.6$$

$$\Delta P = 1590 \times 0.005 \times 38.6 = 306.87 \text{ psf}$$

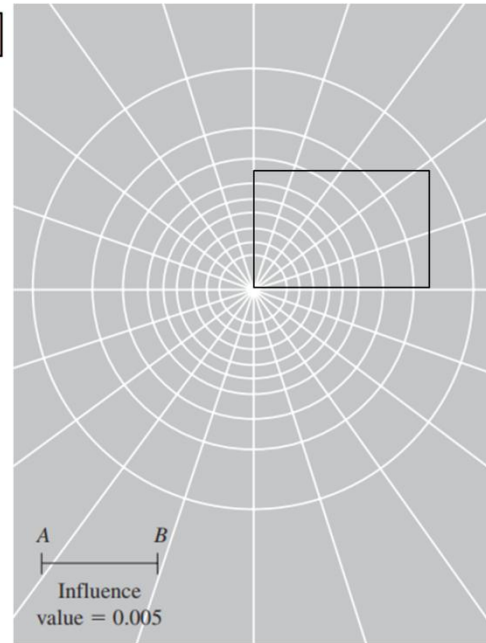

ΔP determination (Newmark's Influence Chart)

Center:

$$AB = 60 \text{ ft}$$

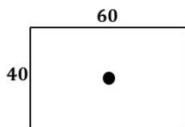

$$\Delta P = q_o I N$$

$$I = \text{Influence Value} = 0.005$$

$$N = \text{Number of Blocks within the Rectangular Area} = 84.8$$

$$\Delta P = 1590 \times 0.005 \times 84.8 = 674.16 \text{ psf}$$

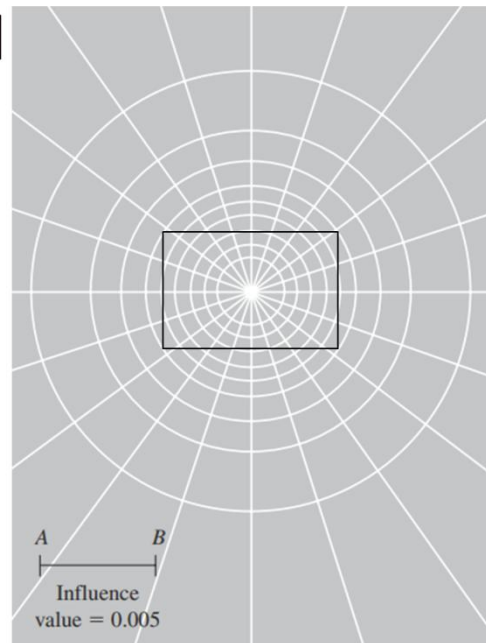

$$S = \frac{C_c H_c}{1 + e_o} \log \left(\frac{P_o + \Delta P}{P_o} \right)$$

$$P_o = 3.728 \text{ ksf} = 3728 \text{ psf}$$

$$C_c = 0.396$$

$$e_o = 1.19$$

$$H_c = 14' = 14 \times 12 = 168''$$

Empherical Formula

Corner:

$$\Delta P = 311.64 \text{ psf}$$

$$S = \frac{0.396 \times 168}{1 + 1.19} \log \left(\frac{3728 + 311.64}{3728} \right)$$

$$= 1.06'' < 2.56'' \quad |$$

Center:

$$\Delta P = 680.52 \text{ psf}$$

$$S = \frac{0.396 \times 168}{1 + 1.19} \log \left(\frac{3728 + 680.52}{3728} \right)$$

$$= 2.21'' < 2.56'' \quad |$$

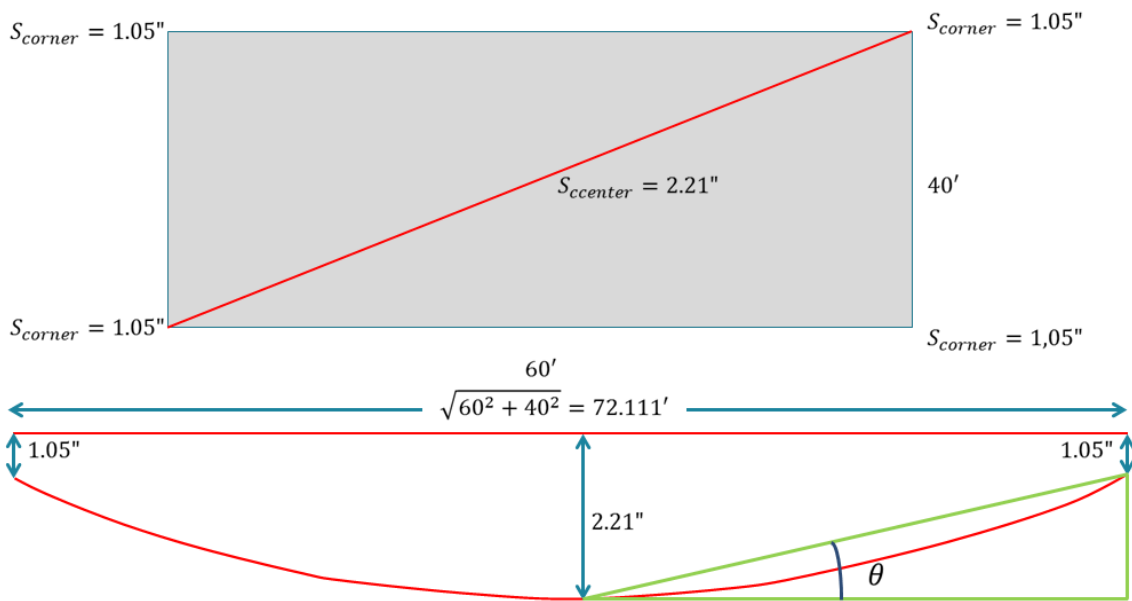

$$\tan \theta \approx \theta = \frac{2.21 - 1.05}{\frac{72.111 \times 12}{2}} = \frac{1}{372.99} < \frac{1}{300} \quad \boxed{\text{OK}}$$

$$S = \frac{C_c H_c}{1 + e_o} \log \left(\frac{P_o + \Delta P}{P_o} \right)$$

$$P_o = 3.728 \text{ ksf} = 3728 \text{ psf}$$

$$C_c = 0.396$$

$$e_o = 1.19$$

$$H_c = 14' = 14 \times 12 = 168''$$

Fadum Chart

Corner:

$$\Delta P = 308.46 \text{ psf}$$

$$S = \frac{0.396 \times 168}{1 + 1.19} \log \left(\frac{3728 + 308.46}{3728} \right)$$

$$= 1.05'' < 2.56'' \text{ [OK]}$$

Center:

$$\Delta P = 680.52 \text{ psf}$$

$$S = \frac{0.396 \times 168}{1 + 1.19} \log \left(\frac{3728 + 680.52}{3728} \right)$$

$$= 2.21'' < 2.56'' \text{ [OK]}$$

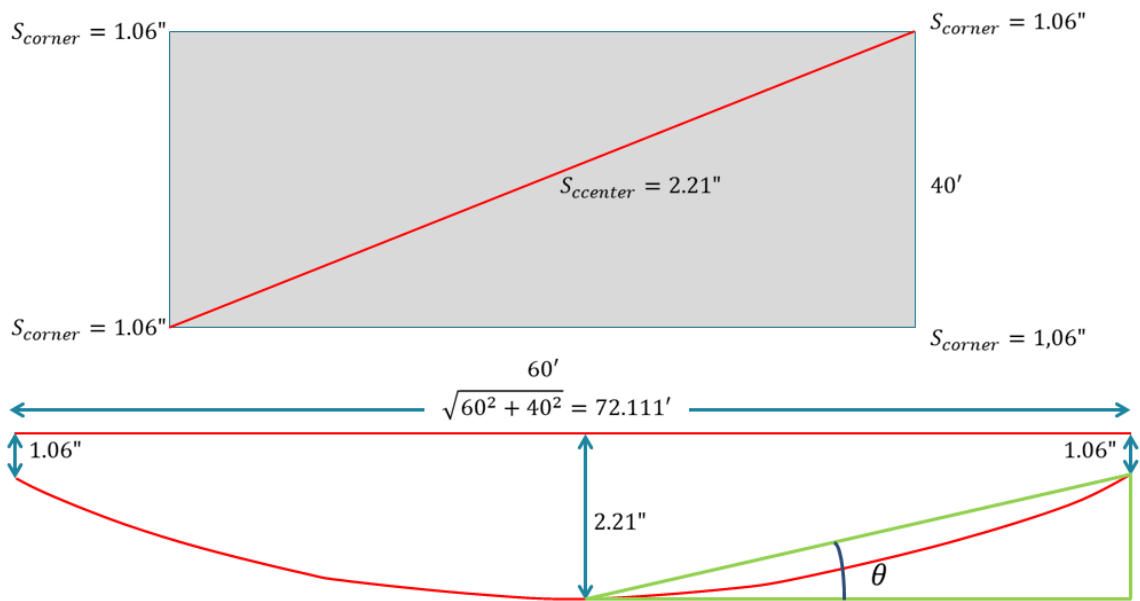

$$\tan \theta \approx \theta = \frac{2.21 - 1.06}{\frac{60^2 + 40^2}{2 \times 12}} = \frac{1}{376.23} < \frac{1}{300} \quad \text{OK}$$

$$S = \frac{C_c H_c}{1 + e_o} \log \left(\frac{P_o + \Delta P}{P_o} \right)$$

$$P_o = 3.728 \text{ ksf} = 3728 \text{ psf}$$

$$C_c = 0.396$$

$$e_o = 1.19$$

$$H_c = 14' = 14 \times 12 = 168''$$

Newmark's Influence Chart

Corner:

$$\Delta P = 306.87 \text{ psf}$$

$$S = \frac{0.396 \times 168}{1 + 1.19} \log \left(\frac{3728 + 306.87}{3728} \right)$$

$$= 1.04'' < 2.56'' \text{ [OK]}$$

Center:

$$\Delta P = 674.16 \text{ psf}$$

$$S = \frac{0.396 \times 168}{1 + 1.19} \log \left(\frac{3728 + 674.16}{3728} \right)$$

$$= 2.19'' < 2.56'' \text{ [OK]}$$

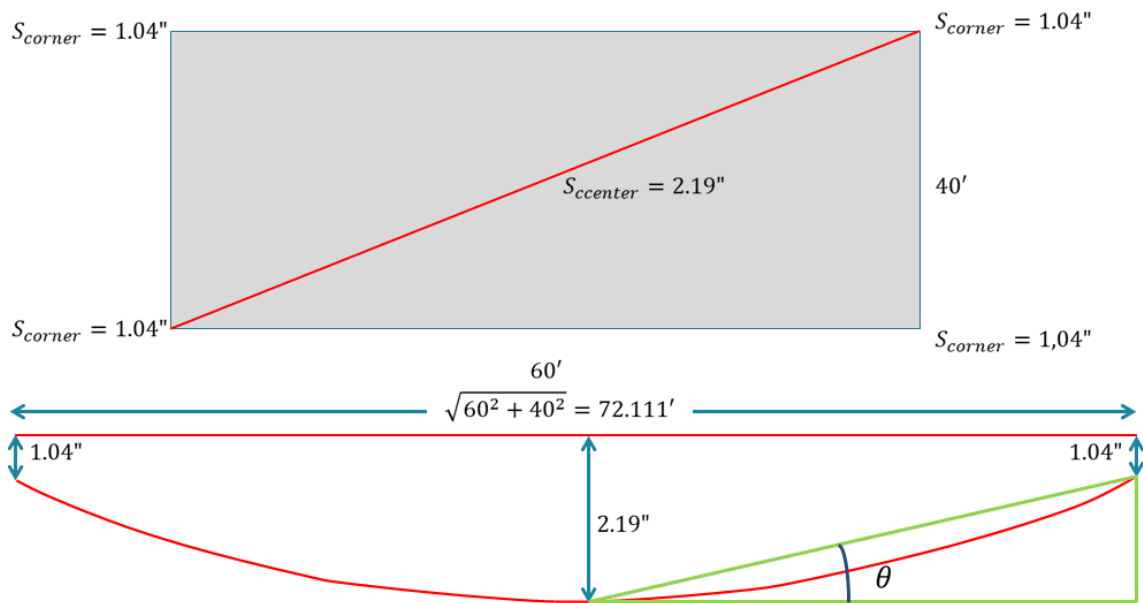

$$\tan \theta \approx \theta = \frac{2.19 - 1.04}{\frac{60' \times 12}{2}} = \frac{1}{376.23} < \frac{1}{300} \quad \text{OK}$$

Example :

Consider a mat foundation 90 ft × 120 ft in plan, as shown in **Figure**. The total dead load and live load on the raft is 45×10^3 kip. Estimate the **consolidation settlement** at the **center** of the foundation.

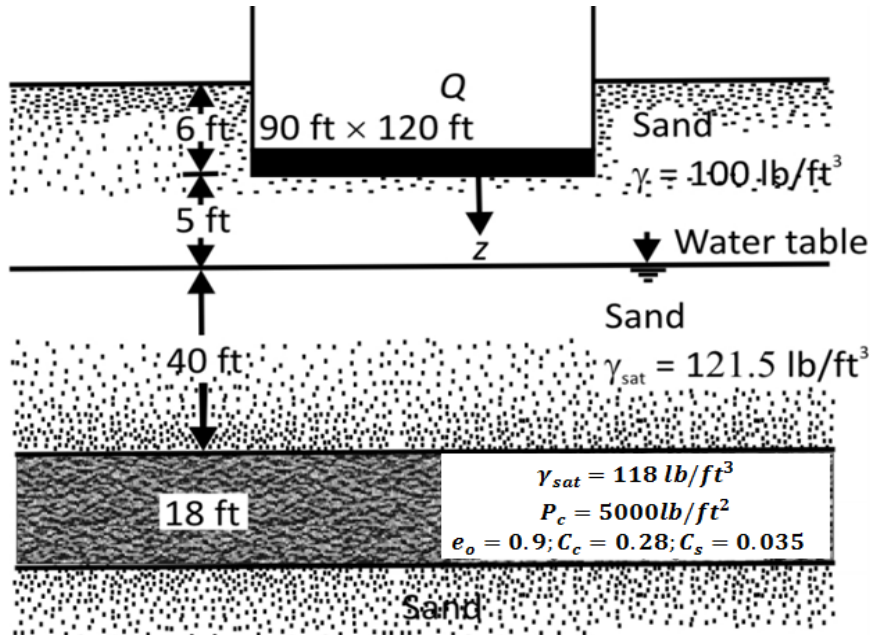

Solution:

ΔP determination (Empirical Formula)

Center:

$$m = \frac{x}{z} = \frac{60}{54} = 1.111$$

$$n = \frac{y}{z} = \frac{45}{54} = 0.833$$

} **Interchangable**

z = distance between **bottom of footing** and **mid clay layer**

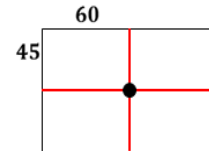

$$q_o = q - \gamma D_f$$

$$= \frac{P}{L \times B} - \gamma D_f$$

$$= \frac{45 \times 10^6}{120 \times 90} - 100 \times 6$$

$$= 3566.67 \text{ psf}$$

$$I = \frac{1}{4\pi} \left[\frac{2mn\sqrt{m^2+n^2+1}}{m^2+n^2+m^2n^2+1} \left(\frac{m^2+n^2+2}{m^2+n^2+1} \right) + \tan^{-1} \left(\frac{2mn\sqrt{m^2+n^2+1}}{m^2+n^2-m^2n^2+1} \right) \right]$$

$$I = 0.168$$

$$\Delta P = 4I \times q_o = 4 \times 0.168 \times 3566.67 = 2396.80 \text{ psf}$$

$$P_o = 11 \times 100 + 40 \times (121.5 - 62.4) + \frac{18}{2} \times (118 - 62.4) = 3964.4 \text{ psf}$$

$$C_c = 0.28$$

$$C_s = 0.035$$

$$e_o = 0.9$$

$$H_c = 18' = 18 \times 12 = 216 \text{ inch}$$

$$\Delta P = 2396.8 \text{ psf}$$

$$P_o + \Delta P = 3964.4 + 2396.8 = 6361.2 \text{ psf}$$

$$P_o < (P_c = 5000 \text{ psf}) < P_o + \Delta P$$

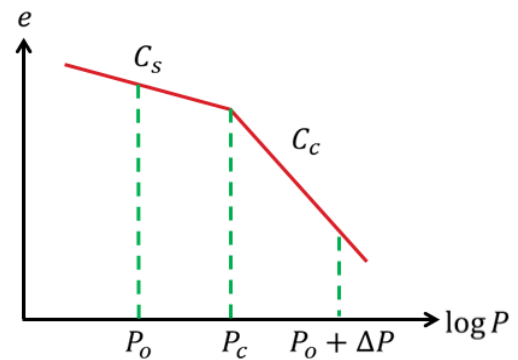

$$S = \frac{C_s H_c}{1 + e_o} \log\left(\frac{P_c}{P_o}\right) + \frac{C_c H_c}{1 + e_o} \log\left(\frac{P_o + \Delta P}{P_c}\right)$$

$$= \frac{0.035 \times 216}{1 + 0.9} \log\left(\frac{5000}{3964.4}\right) + \frac{0.28 \times 216}{1 + 0.9} \log\left(\frac{6361.2}{5000}\right)$$

$$= 3.73" (< 3.94 \text{ in}) \quad \text{OK}$$

Skempton and MacDonald suggested the following permissible settlements

SANDS

- Maximum total settlement = 40 mm for isolated footing
 = 40 – 65 mm for rafts.
 Maximum differential settlement = 25 mm between adjacent columns.

CLAYS

- Maximum total settlement = 65 mm for isolated footing
 = 65 – 100 mm for rafts.
 Maximum differential settlement = 40 mm between adjacent columns.

CHAPTER 7

STRUCTURAL DESIGN OF FOUNDATION

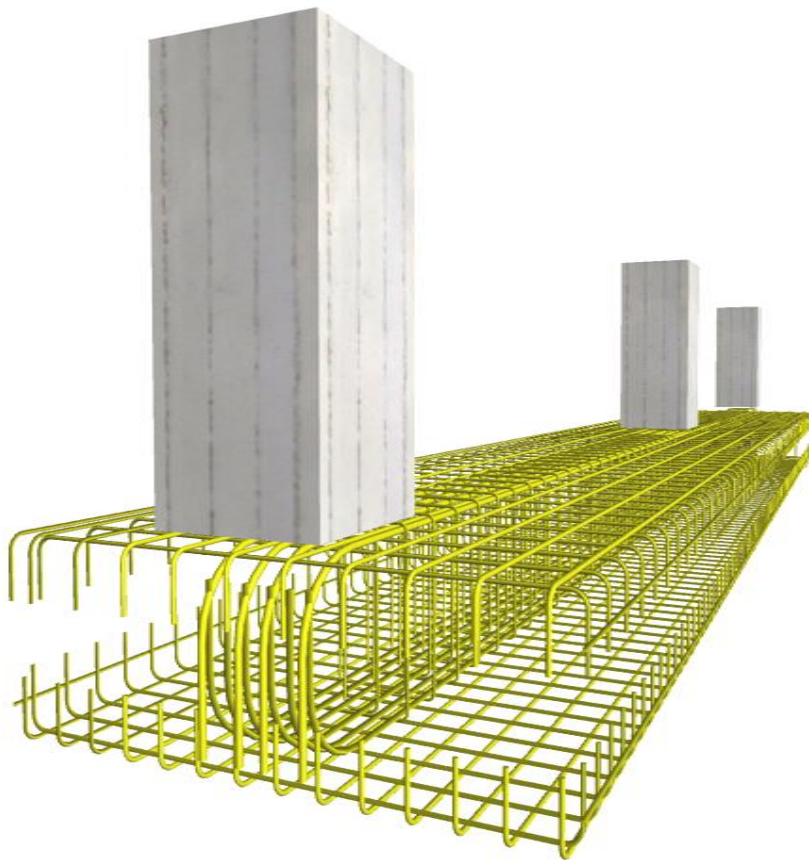

Design of Isolated Footing

Step 1: Footing size

Column load (DL+LL) = P

Considering self weight of footing is 3% of column load.

$$\# \text{ Footing area, } A = \frac{P \times 1.03}{q_a} \text{ (rounded value)} \quad (7.1)$$

$$\# \text{ Width of footing, } B = \sqrt{A} \text{ (for square footing)} \quad (7.2)$$

$$\# \text{ Net under pressure producing shear and bending, } q_{net} = \frac{1.2DL + 1.6LL}{A} \quad (7.3)$$

Assume any thickness = t

Assuming t :

Footing length	Thickness
3'	12"
8'	2'
10'	2.5'
12'	3'

Step 2: Punching Shear Check

Punching Shear:

$$V = P - \frac{(a+d)(b+d)}{144} \times q_{net} \quad (7.4)$$

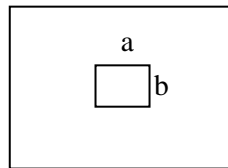

Here,

a, b = column dimension

d = t-3

(3" clear cover at footing)

Resistive/ Allowable Shear:

$$V = 2\sqrt{f_c'} b_o d \text{ (WSD)} \quad (7.5)$$

$$V = 4\phi\sqrt{f_c'} b_o d \text{ (USD)} \quad (7.6)$$

$$* b_o = 2(a+d) + 2(b+d) \quad (7.7)$$

* If resistive/ allowable shear is greater than punching shear than ok. If smaller than increase thickness.

Step 3: Beam Shear Check

Beam Shear:

$$V = q_{net} d_o \quad (7.8)$$

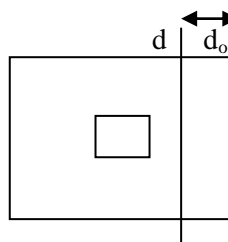

Resistive/ Allowable Shear:

$$V = 1.1\sqrt{f_c'} b_o d \text{ (WSD)} \quad (7.9)$$

$$V = 2\phi\sqrt{f_c'} b_o d \text{ (USD)} \quad (7.10)$$

Step 4: Moment calculation

$$\text{Moment, } M = \frac{q_{net} L^2}{2}$$

For short direction, M_s

For long direction, M_L

(For square footing both side is equal,

So moment will be same.)

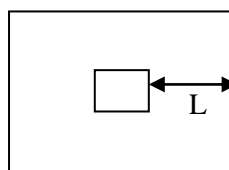

Step 5: Reinforcement calculation

WSD method:

$$\# n = \frac{E_s}{E_c} = \frac{E_s}{57000 \sqrt{f'_c}} \quad (7.11)$$

$$\# r = \frac{f_s}{f_c} = \frac{0.4 f_y}{0.45 f_c} \quad (7.12)$$

$$\# k = \frac{n}{n+r} \quad (7.13)$$

$$\# J = 1 - \frac{K}{3} \quad (7.14)$$

$$\# R = \frac{f_c}{2} kJ \quad (7.15)$$

$$\# d = \sqrt{\frac{M}{Rb}} \quad (7.16)$$

$$\# A_s = \frac{M}{f_s J d} \quad (7.17)$$

$$\# A_{s \text{ min}} = \frac{200}{f_y} bd \quad (7.18)$$

USD method:

$$\# \rho_{\max} = 0.85 \beta_1 \frac{f'_c}{f_y} \frac{\epsilon_u}{\epsilon_u + \epsilon_y} \quad (7.19)$$

$$\# R = \rho_{\max} f_y (1 - 0.59 \rho_{\max} \frac{f_y}{f_c}) \quad (7.20)$$

$$\# d = \sqrt{\frac{M}{Rb}} \quad (7.21)$$

$$\# A_s = \frac{M}{0.9 f_y (d - \frac{a}{2})} \text{ check. } a = \frac{A_s f_y}{0.85 f_c b} \quad (7.22)$$

Reinforcement at band width:

$$\text{Band width, } \beta = \frac{L}{B} \quad (7.23)$$

$$A_s \text{ in band width} = A_s \times \frac{2}{\beta + 1} \quad (7.24)$$

Detailing:

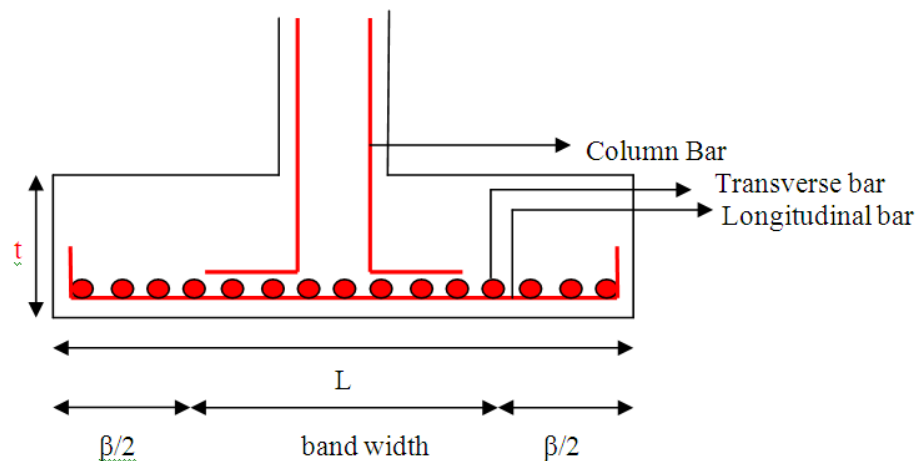
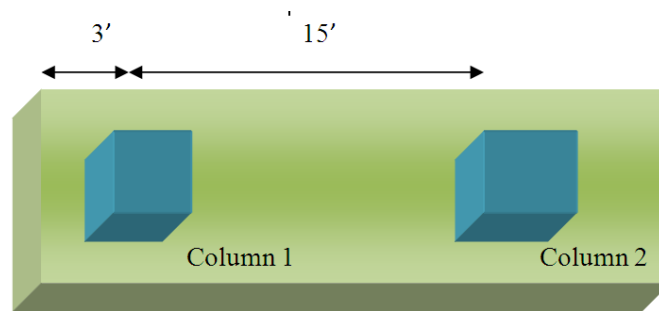

Figure 7.1: Detailing of Footing

Design of Combined Footing



Problem 7.1:

Given Data:

Column 1:

Size: 16" X 20"
Dead Load: 150 kips
Live Load: 100 Kips

Column 2:

Size: 20" X 20"
Dead Load: 230 kips
Live Load: 180 Kips

Center to center distance between columns: 15'
Limited length from column 1 to edge: 3'
Depth of foundation: 5'
Allowable Bearing capacity of soil: 6 ksf
Concrete compressive strength: 3ksi
Yield strength of steel: 60 ksi

Design the footing

Solution:

Step 1: Calculation of footing size

Assume the average unit weight of concrete and soil filling 5' from EGI is $\frac{100+150}{2} = 125$ psf

So pressure due to soil and concrete = $5 \times 125 = 625$ psf

Available bearing pressure of soil for footing, $q_a = 6000 - 625 = 5375$ psf = 5.375ksf

Required footing area = $\frac{DL+LL}{q_a} = \frac{(230+150)+(180+100)}{5.375} = 122.8$ sft

Now we have to find the resultant of column loads.

Distance from the left column: $\frac{(150+100) \times 0 + (230+180) \times 15}{(150+100+230+180)} = 9.32'$

So the length existing of left side of the resultant force point is $9.32+3 = 12.32$

So, total length is $12.32+12.32 = 24.64'$. Select 25'

Required width = $\frac{122.8}{25} = 4.912'$ Select 5'

Size of the combined footing is 25'X5'

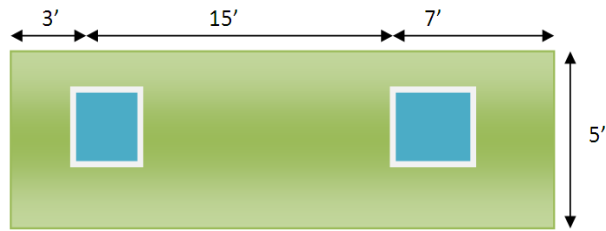

Step 2: Draw SFD & BMD of the Footing

Factored load on exterior column = $1.2 \times 150 + 1.6 \times 100 = 320\text{K}$

Factored load on exterior column = $1.2 \times 230 + 1.6 \times 180 = 564\text{K}$

Net upward ultimate pressure = $\frac{\text{Total Load}}{\text{Area of footing}} = \frac{320+564}{25 \times 5} = 7.232\text{K/ft}$

Width of footing = 5'

Longitudinal load per feet = $7.232 \times 5 = 36.16'$

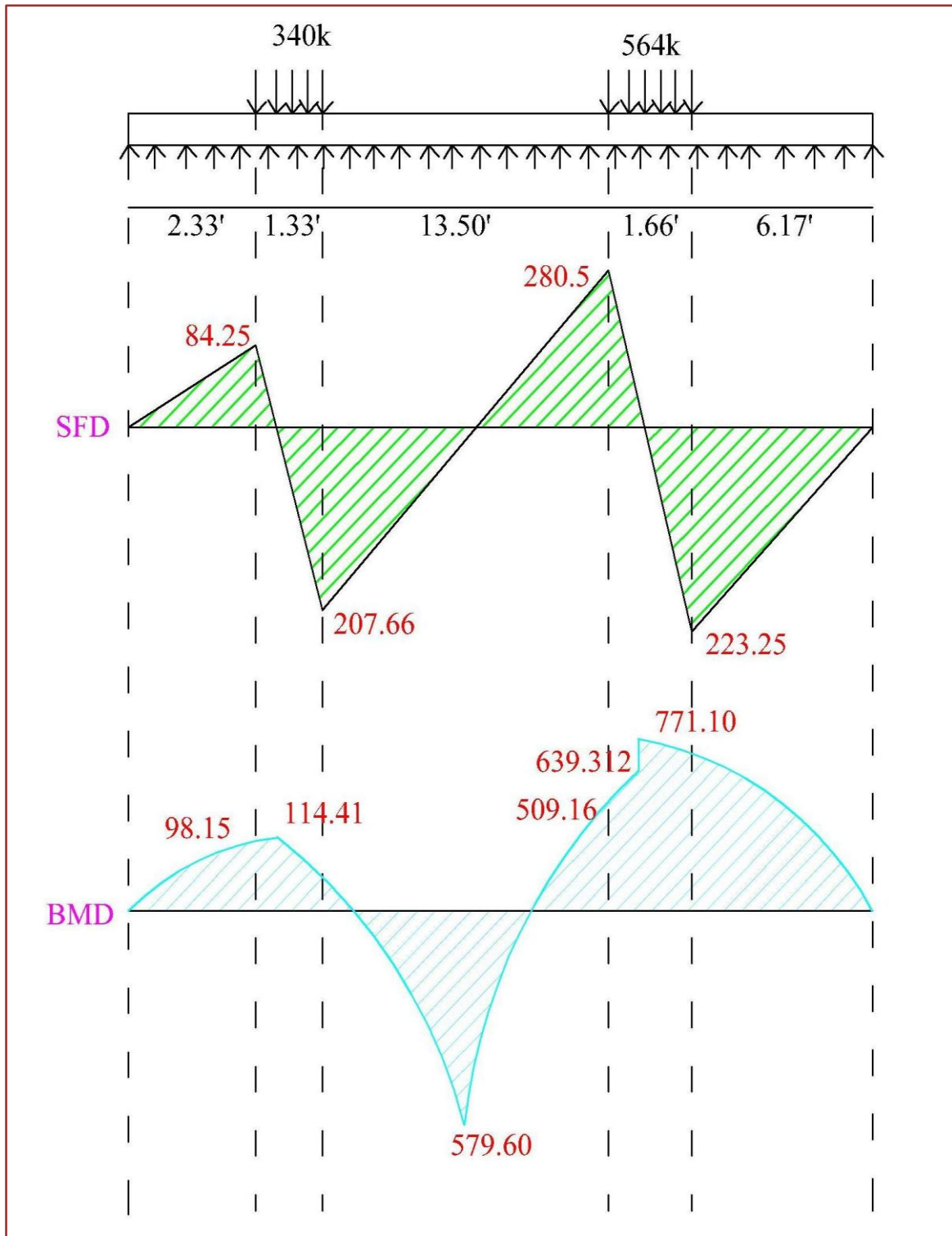

Step 3: Design Beam & punching Shear

Let thickness of footing = 25" + 5" = 30" so $d = 30 - 3 = 27"$

Beam Shear check:

Allowable shear = $2\phi\sqrt{f'_c}Bd = 2 \times 0.75 \times \sqrt{3000} \times (5 \times 12) \times 27 / 1000 = 133.09 \text{ kip}$

According to the Shear force diagram, maximum shear force occurs at the left side of the interior support.

So the shear force at 27" from the interior support is = 198.84kip > 133.09 kip (Not Ok)

Increase the footing thickness.

Try $t = 40''$. So, $d = 40 - 3 = 37''$

Allowable shear $= 2 \phi \sqrt{f'_c} B d = 2 \times 0.75 \times \sqrt{3000} \times (5 \times 12) \times 37 / 1000 = 182.39 \text{ k}$

Shear force at 37" from the interior support is $= 168.44 \text{ kip} < 182.09 \text{ kip}$ (Ok)

Punching Shear check:

Punching Shear is resisted by an area on which column sides down scratching the footing. For a column, the area of punching is composed of four vertical surface that have width equal to column dimension $+ d/2$

Allowable shear $= 4 \phi \sqrt{f'_c} \phi b d = 4 \times 0.75 \times \sqrt{3000} \times [2\{16 + 37/2\} + 2\{20 + 37/2\}] \times 37 = 851 \text{ K}$

Resisting Shear = Column load – upward force

$$= 340 - 7.232 \times \left(\frac{16 + 37/2}{12}\right) \times \left(\frac{20 + 37/2}{12}\right) = 273.3 \text{ kip} \ll 851 \text{ kip} \text{ (OK)}$$

Step 4: Reinforcement Calculation

Longitudinal direction:

According to bending moment diagram, maximum –ve moment $= 579.60 \text{ Kip}$.

$$\text{Assume, } a = 1.5 \text{ thus } A_s = \frac{M}{\phi f_y (d - a/2)} = \frac{579.60 \times 1000 \times 12}{0.9 \times 60000 \times (37 - 1.5/2)} = 3.553 \text{ in}^2$$

$$\text{Check } a, a = \frac{A_s f_y}{0.85 f'_c b} = \frac{3.553 \times 60000}{0.85 \times 3000 \times 5 \times 12} = 1.393$$

$$\text{Assume } a = 1.4, \text{ thus } A_s = \frac{M}{\phi f_y (d - a/2)} = \frac{579.60 \times 1000 \times 12}{0.9 \times 60000 \times (37 - 1.4/2)} = \mathbf{3.548 \text{ in}^2}$$

$$\text{Check } a, a = \frac{A_s f_y}{0.85 f'_c b} = \frac{3.548 \times 60000}{0.85 \times 3000 \times 5 \times 12} = 1.39 \text{ (ok)}$$

According to bending moment diagram, maximum +ve moment $= 771.10 \text{ Kip}$

$$\text{Assume, } a = 1.9 \text{ thus } A_s = \frac{M}{\phi f_y (d - a/2)} = \frac{771.10 \times 1000 \times 12}{0.9 \times 60000 \times (37 - 1.9/2)} = \mathbf{4.753 \text{ in}^2}$$

$$\text{Check } a, a = \frac{A_s f_y}{0.85 f'_c b} = \frac{4.753 \times 60000}{0.85 \times 3000 \times 5 \times 12} = 1.86 = 1.9 \text{ (ok)}$$

Minimum reinforcement:

$$A_{s \text{ min}} = \frac{3 \times \sqrt{f'_c} b d}{f_y} = \frac{3 \times \sqrt{3000} \times 5 \times 12 \times 37}{60000} = 6.079 \text{ in}^2$$

$$A_{s \text{ min}} = \frac{200 b d}{f_y} = \frac{200 \times 5 \times 12 \times 37}{60000} = \mathbf{7.4 \text{ in}^2}$$

So use $A_s 7.4 \text{ in}^2$ both in top and bottom along long direction.

If we use #6 or $\phi 20$, we have to provide $7.4 / .44 = 16.81 = 17 \text{ pc}$.

Use 17-#6 bar along long direction both at top and bottom.

Transverse direction:

Under interior column:

$$\text{Transverse length} = 20'' + 2 \times 37/2 = 57'' = \mathbf{4.75'}$$

$$\text{Width of footing} = 5'$$

$$\text{Column Load} = 564 \text{ K}$$

$$\text{Upward pressure from soil along transverse span direction} = 564/5 = 112.8 \text{ k/ft}$$

Reinforcement is designed for moment at the face of the column, where bending moment,

$$M = wL^2/2 = 112.8 \times 1.666^2/2 = 156.60$$

$$\text{Assume, } a = .4 \text{ thus } A_s = \frac{M}{\phi f_y (d-a/2)} = \frac{156.60 \times 1000 \times 12}{.9 \times 60000 \times (37-.4/2)} = \mathbf{0.946 \text{ in}^2}$$

$$\text{Check } a, a = \frac{A_s f_y}{.85 f'_c b} = \frac{0.946 \times 60000}{.85 \times 3000 \times 5 \times 12} = .37 = .4 \text{ (ok)}$$

Minimum reinforcement:

$$A_{s \text{ min}} = \frac{3 \times \sqrt{f'_c} b d}{f_y} = \frac{3 \times \sqrt{3000} \times 57 \times 37}{60000} = 5.775 \text{ in}^2$$

$$A_{s \text{ min}} = \frac{200 b d}{f_y} = \frac{200 \times 57 \times 37}{60000} = \mathbf{7.03 \text{ in}^2}$$

Use **7.03 in²** over longitudinal bar under interior column along 4.75'

Use 16-#6 under interior column.

Under exterior column:

$$\text{Transverse length} = 16'' + 2 \times 37/2 = 53'' = 4.416'$$

$$\text{Width of footing} = 5'$$

$$\text{Column Load} = 340 \text{ K}$$

$$\text{Upward pressure from soil along transverse span direction} = 340/5 = 68 \text{ k/ft}$$

Reinforcement is designed for moment at the face of the column, where bending moment,

$$M = wL^2/2 = 68 \times 1.666^2/2 = 94.368$$

$$\text{Assume, } a = .23 \text{ thus } A_s = \frac{M}{\phi f_y (d-a/2)} = \frac{94.368 \times 1000 \times 12}{.9 \times 60000 \times (37-.23/2)} = \mathbf{0.569 \text{ in}^2}$$

$$\text{Check } a, a = \frac{A_s f_y}{.85 f'_c b} = \frac{0.569 \times 60000}{.85 \times 3000 \times 5 \times 12} = .22 = .23 \text{ (ok)}$$

Minimum reinforcement:

$$A_{s \text{ min}} = \frac{3 x \sqrt{f'_c} bd}{f_y} = \frac{3 x \sqrt{3000} x 53 x 37}{60000} = 5.37 \text{ in}^2$$

$$A_{s \text{ min}} = \frac{200 bd}{f_y} = \frac{200 x 53 x 37}{60000} = \mathbf{6.54 \text{ in}^2}$$

Use **6.54 in²** over longitudinal bar under interior column along 4.416'

Use **15-#6** under exterior column.

Step 4: Detailing

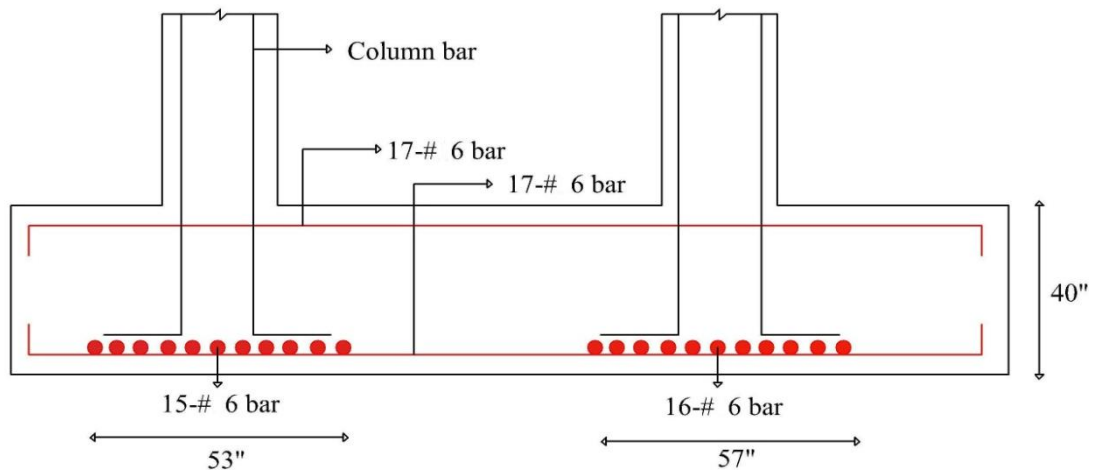

Problem 7.2:

A six storied residential building is supported on 16 columns arranged as shown in plan in Fig. Three sized columns used, C1 = 14" * 14", C2 = 14" * 16" & C3 = 20" * 20". For column C1, C2 and C3 the dead loads are: 241Kip, 401Kip and 673kip and live loads are: 47Kip, 89Kip and 168Kip. Concrete compressive strength is 3500 psi and Steel yield strength is 60000 psi. Design the mat foundation.

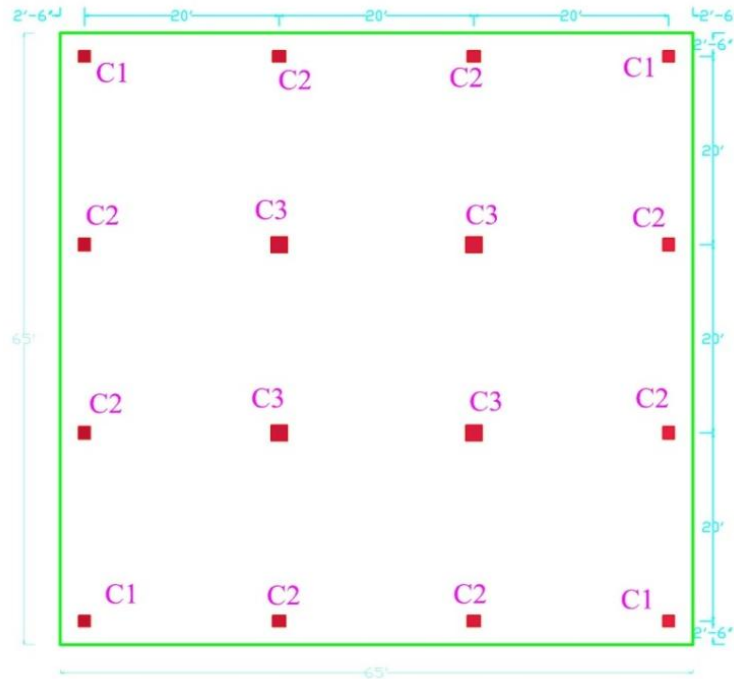

Solution

Determination of Mat thickness by punching shear

Punching shear check for corner column C1

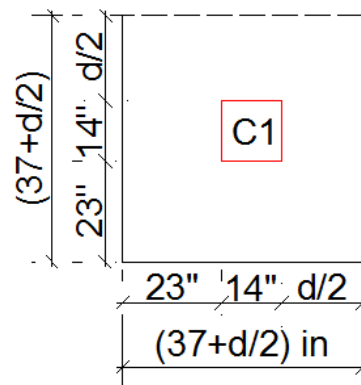

Ultimate Load

$$\begin{aligned}
 P_U &= 1.2 \times DL + 1.6 \times LL \\
 &= 1.2 \times 241 + 1.6 \times 47 \\
 &= 364.4 \text{ kip} = 364 \text{ kip}
 \end{aligned}$$

$$\text{Punching perimeter, } b_0 = \left(37 + \frac{d}{2}\right) * 4$$

$$= (148 + 2d) \text{ in}$$

According to ACI Code,

$$\phi V_c \geq V_u$$

Where, V_c = nominal shear strength of concrete

V_u = factored shear strength of concrete

We know,

$$\begin{aligned} \phi V_c &= 4 \phi \sqrt{f'_c} b_0 \cdot d \\ &= 4 \times 0.85 \times \sqrt{3500} \times (148 + 2d) && [b_0 = (37 + d/2) * 4] \\ &= \frac{201.15 \times (148 + 2d) \times d}{1000} \text{ kip} \\ V_u &= P_u = 364 \text{ kip} \\ &= \frac{201.15 \times (148 + 2d) \times d}{1000} \geq 364 \\ &= (148 + 2d) \times d \geq 1811.58 \\ &= 2d^2 + 148d \geq 1811.58 \end{aligned}$$

By solving the equation

$$d_1 = 10.69''$$

$$d_2 = -84.69''$$

$$d \geq 10.69''$$

Select for design, $d = 12''$

With a minimum cover of 3 inch over the steel reinforcement and 1 inch diameter steel bars, the total slab thickness, $h = 12 + 3 + 1 = 16''$

Punching Shear for Exterior Column C2

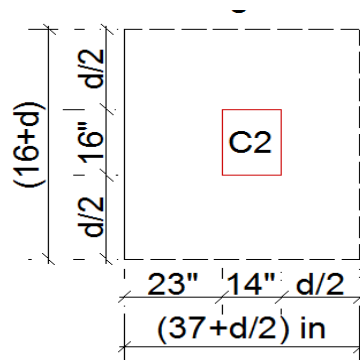

Ultimate Load

$$\begin{aligned} P_u &= 1.2 \text{ dead load} + 1.6 \text{ live load} \\ &= 1.2 \times 401 + 1.6 \times 89 = 623.6 \text{ kip} = 624 \text{ kip} \end{aligned}$$

$$\begin{aligned} \text{Punching perimeter, } b_0 &= \left(37 + \frac{d}{2}\right) * 2 + (16 + d) * 2 \\ &= (148 + 2d) + 32 + 2d \\ &= (180 + 4d) \text{ in} \end{aligned}$$

According to ACI Code,

$$\phi V_c \geq V_u$$

Where, V_c = nominal shear strength of concrete

V_u = factored shear strength of concrete

We know,

$$\begin{aligned} \phi V_c &= 4\phi \sqrt{f'c} b_o \cdot d \\ &= 4 * 0.85 * \sqrt{3500} * (180 + 4d) && [b_o = (37+d/2)*2 + (16+d)*2] \\ &= 201.15 * (180+4d) * d \text{ lb} \\ &= \frac{201.15 * (180 + 4d) * d}{1000} \text{ kip} \end{aligned}$$

$$V_u = P_u = 624 \text{ kip}$$

$$\begin{aligned} &= \frac{201.15 * (176 + 4d) * d}{1000} \geq 624 \\ &= (180+4d) d \geq 3100.17 \\ &= 4d^2 + 180d \geq 3100.17 \end{aligned}$$

By solving the equation

$$d_1 = 13.29''$$

$$d_2 = -58.30''$$

$$d \geq 13.29''$$

Select for design, $d = 14''$

With a minimum cover of 3 inch over the steel reinforcement and 1 inch diameter steel bars, the total slab thickness, $h = 14+3+1 = 18''$

Punching Shear for Interior Column C3

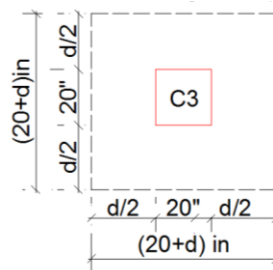

Ultimate Load

$$\begin{aligned} P_u &= 1.2 \text{ dead load} + 1.6 \text{ live load} \\ &= 1.2 * 673 + 1.6 * 168 = 1076.4 \text{ kip} = 1076 \text{ kip} \end{aligned}$$

$$\begin{aligned} \text{Punching perimeter, } b_o &= (20 + d) * 4 \\ &= (80 + 4d) \\ &= (80 + 4d) \text{ in} \end{aligned}$$

According to ACI Code,

$$\phi V_c \geq V_u$$

Where, V_c = nominal shear strength of concrete

V_u = factored shear strength of concrete

We know,

$$\begin{aligned} \phi V_c &= 4\phi \sqrt{f'c} b_o \cdot d \\ &= 4 * 0.85 * \sqrt{3500} * (20 + d) * 4 * d && [b_o = (37+d/2)*2 + (16+d)*2] \\ &= 201.15 * (80+4d) * d \text{ lb} \end{aligned}$$

$$= \frac{201.15 * (80 + 4d) * d}{1000} \text{ kip}$$

$$V_u = P_u = 1076 \text{ kip}$$

$$= \frac{201.15 * (80 + 4d) * d}{1000} \geq 1076$$

$$= (80+4d) d \geq 5351.23$$

$$= 4d^2 + 80d \geq 5351.23$$

By solving the equation

$$d_1 = 27.92''$$

$$d_2 = -47.92''$$

$$d \geq 27.92''$$

Select for design, $d = 28''$

With a minimum cover of 3 inch over the steel reinforcement and 1 inch diameter steel bars, the total slab thickness, $h = 28+3+1 = 32''$

Final Selection of Mat thickness

Mat thickness for Column	C1	=	16''
	C2	=	18''
	C3	=	32''

So, the thickness of mat foundation is equal to 32''

Steel Calculation:

Load diagram for Side Strip of mat foundation (strip size 65' X 12.5'):



Load diagram:

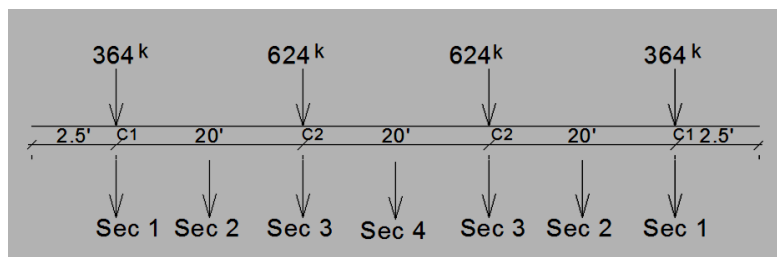

Shear and moment diagram for side strip:

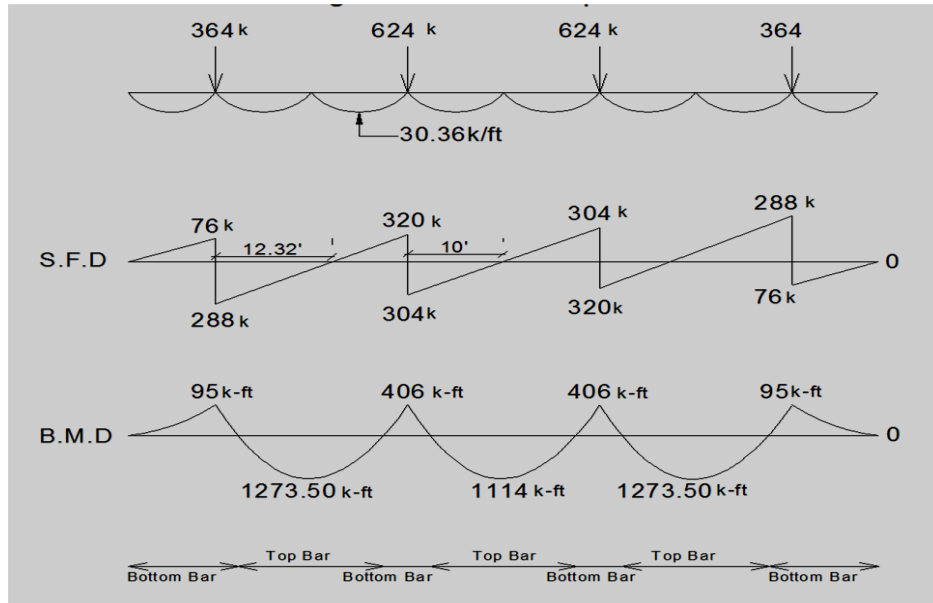

Moment Chart for Interior panel, Length-65', Width-12.5':

Panel Section	Positive Moment		Negative Moment	
	Total Moment k-ft	Moment k-ft/ft	Total Moment k-ft	Moment k-ft/ft
Section 1	95	7.6		
Section 3	406	32.48		
Section 2			1273.50	101.88
Section 4			1114	89.12

General formula for Steel Calculation

$$A_s = \frac{M_u}{\phi_y (d - a/2)}$$

$$a = \frac{A_s M_u}{0.85 f'c b}$$

$$A_s = \frac{101.88 * 12}{.9 * 60(32 - 2/2)} \quad (\text{Let } a = 2 \text{ inch}); \text{ check } a = \frac{A_s M_u}{0.85 f'c b}$$

$$A_s = 0.72 \text{ in}^2 \quad = \frac{.72 * 101.88}{0.85 * 3.5 * 12} = 2 \text{ inch (ok)}$$

Minimum Steel according to ACI Code

$$A_{s, \min} = 0.0018 bt$$

Where, b = 12" and t = total thickness of mat

$$\text{Minimum steel according to ACI code} = 0.0018 * 12 * 32 = 0.69 \text{ in}^2$$

Steel for Interior Panel

Section	Positive Steel (in ²)		Negative Steel (in ²)	
	Section – 1	0.69	# 5 bar @ 5" c/c	
Section – 3	0.69	# 5 bar @ 5" c/c		
Section – 2			0.72	# 5 bar @5"c/c
Section – 4			0.69	# 5 bar @5"c/c

Do the same for Mid Strip of mat foundation (strip size 65' X 20'):

APPENDIX

APPENDIX 1

WORK TO DO

The column-beam layout plan is of a four storied residential building. Different parameters are given below. A soil test report is also provided with this Lab manual.

Slab Thickness: 6"

Columns C1 = 10" X 10"

C2 = 12" X 12"

C3 = 12" X 14"

Beams B1 = 12" X 18"

B2 = 12" X 20"

Live Load = (60 - a) psf

Floor Finish = (25 + a) psf

Partition Wall = (50 + a) psf

$f'_c = (3 + a)$ ksi

$f_y = (60 - a)$ ksi

Factor, a = (Last two digits of roll x 0.1)

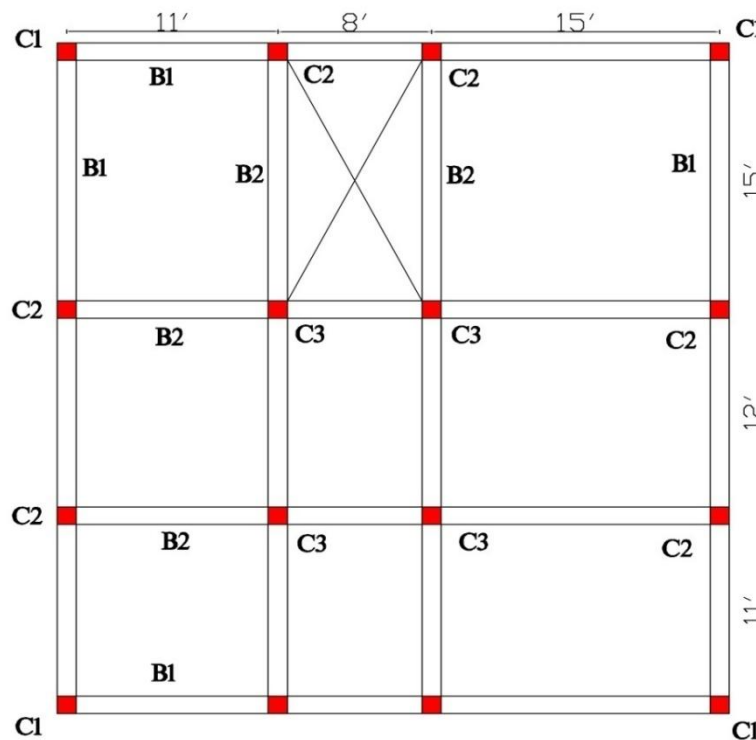

1. Calculate the foundation load from each column.
2. Calculate the bearing capacity and footing size if shallow foundation is provided.
3. Calculate the bearing capacity and footing size if deep foundation is provided.
4. Calculate the bearing capacity and footing size if mat foundation is provided.
5. Calculate consolidation settlement for soil under each column and also calculate the differential settlement of columns and check the angular rotation.
6. Design the Isolated footings, Combined Footings, Mat Foundation.

APPENDIX 2
SOIL TEST REPORT

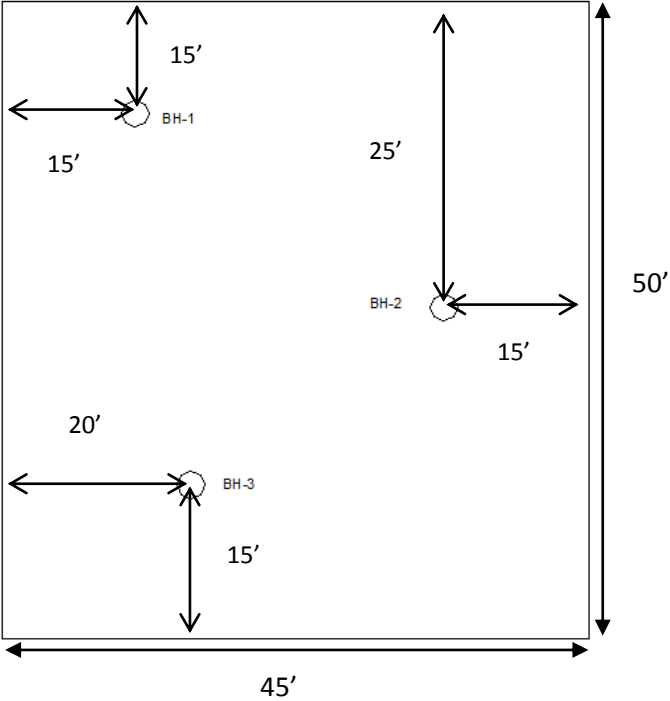

Site Plan

SPT Bore Log

BH No. : 01

Grown Water Table: 1.90 m below

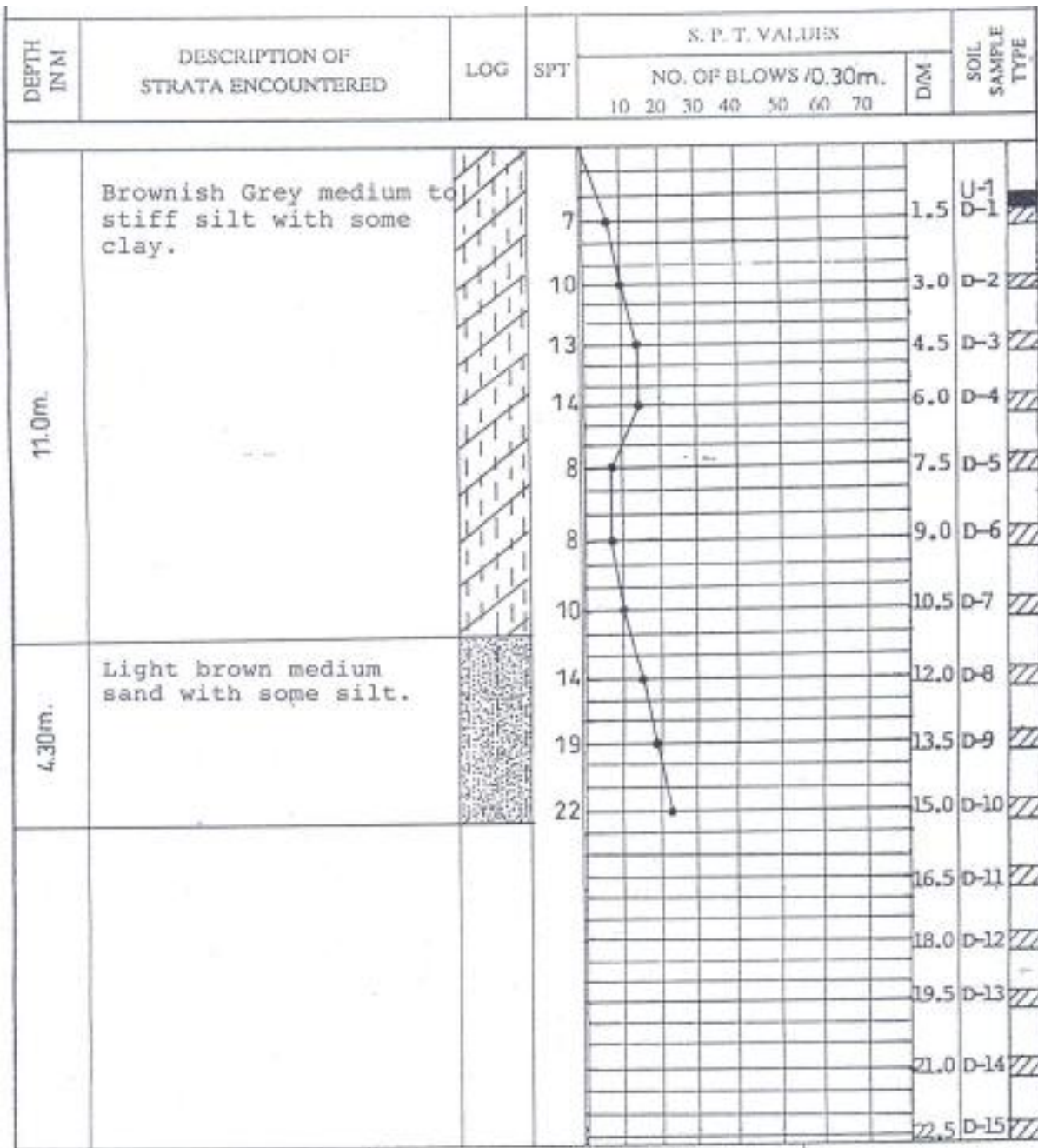

BH No. : 02

Grown Water Table: 1.90 m below

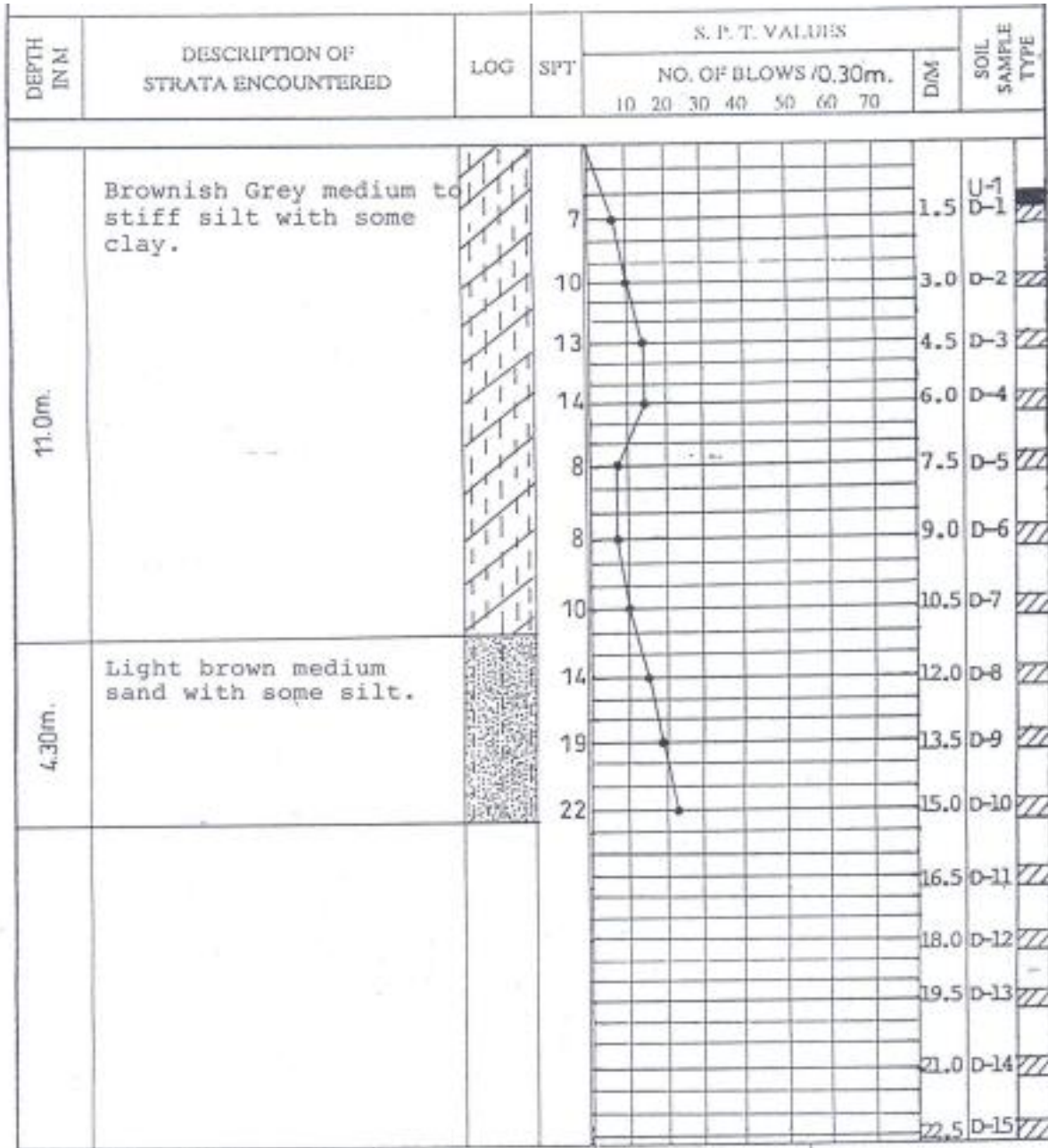

Unconfined Compression Test

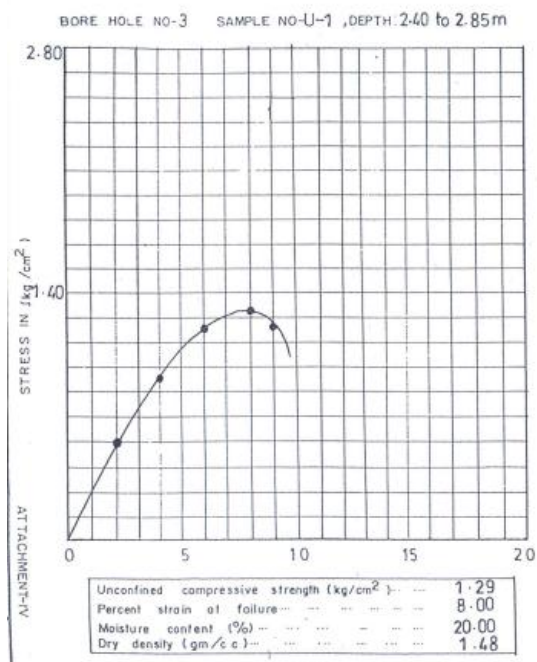
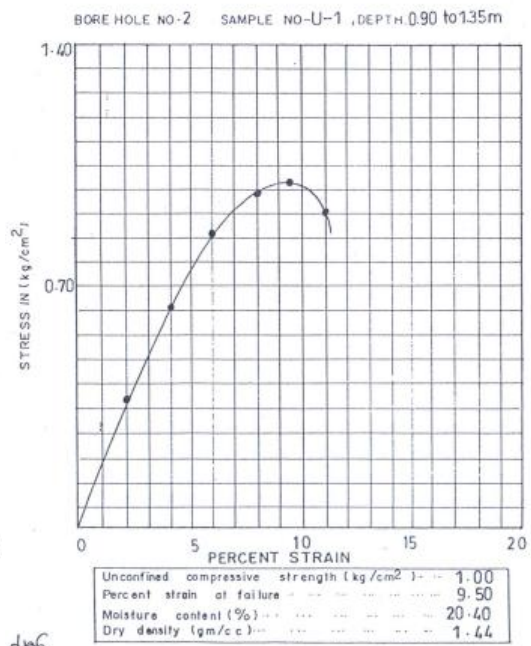
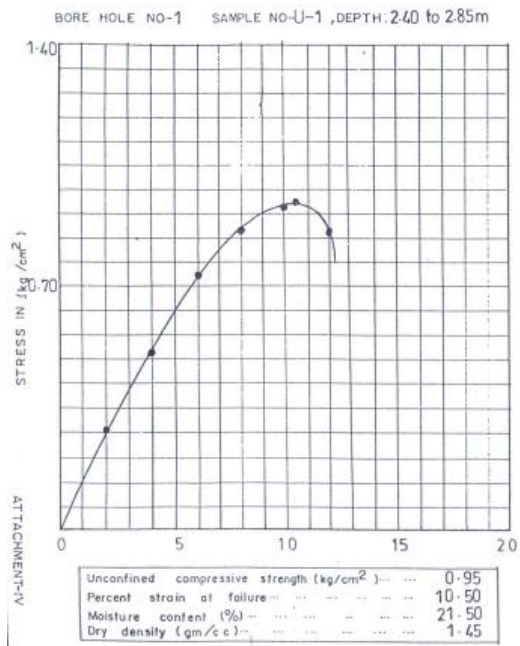

Direct Shear Test

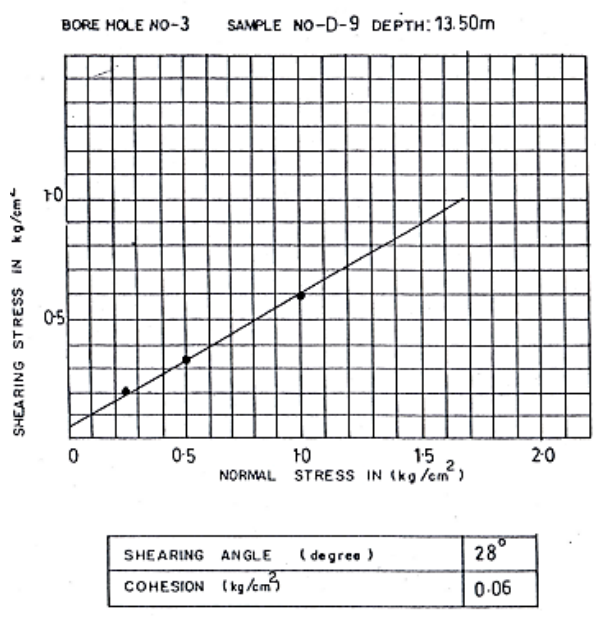
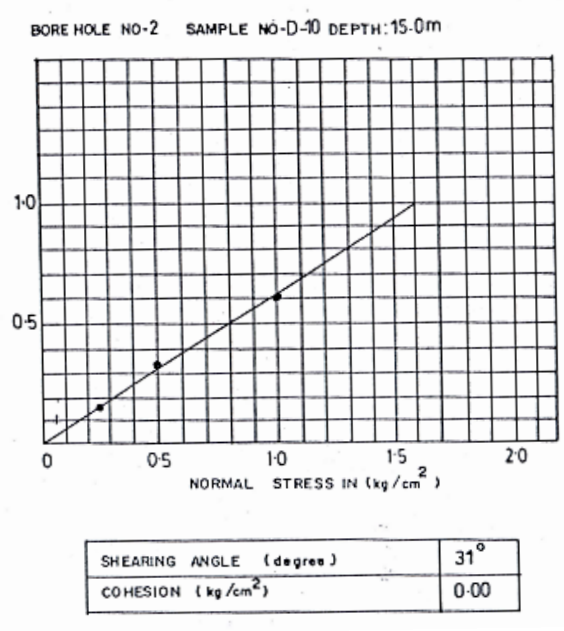
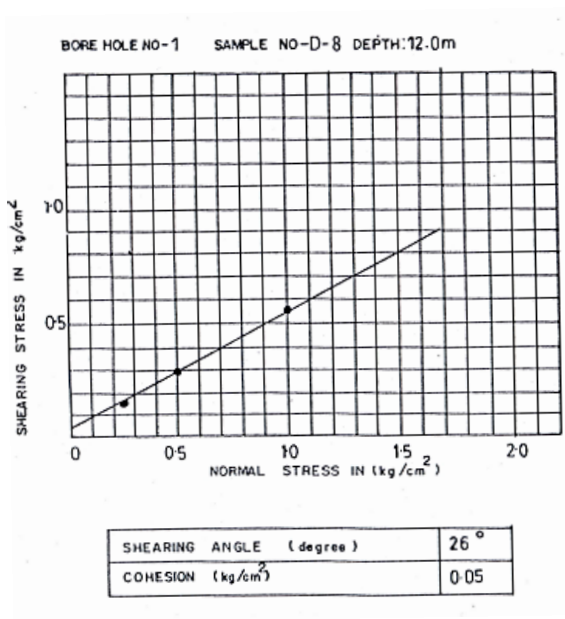

Consolidation Test

BH No. : 01
 Depth: 2.4 m to 2.85 m

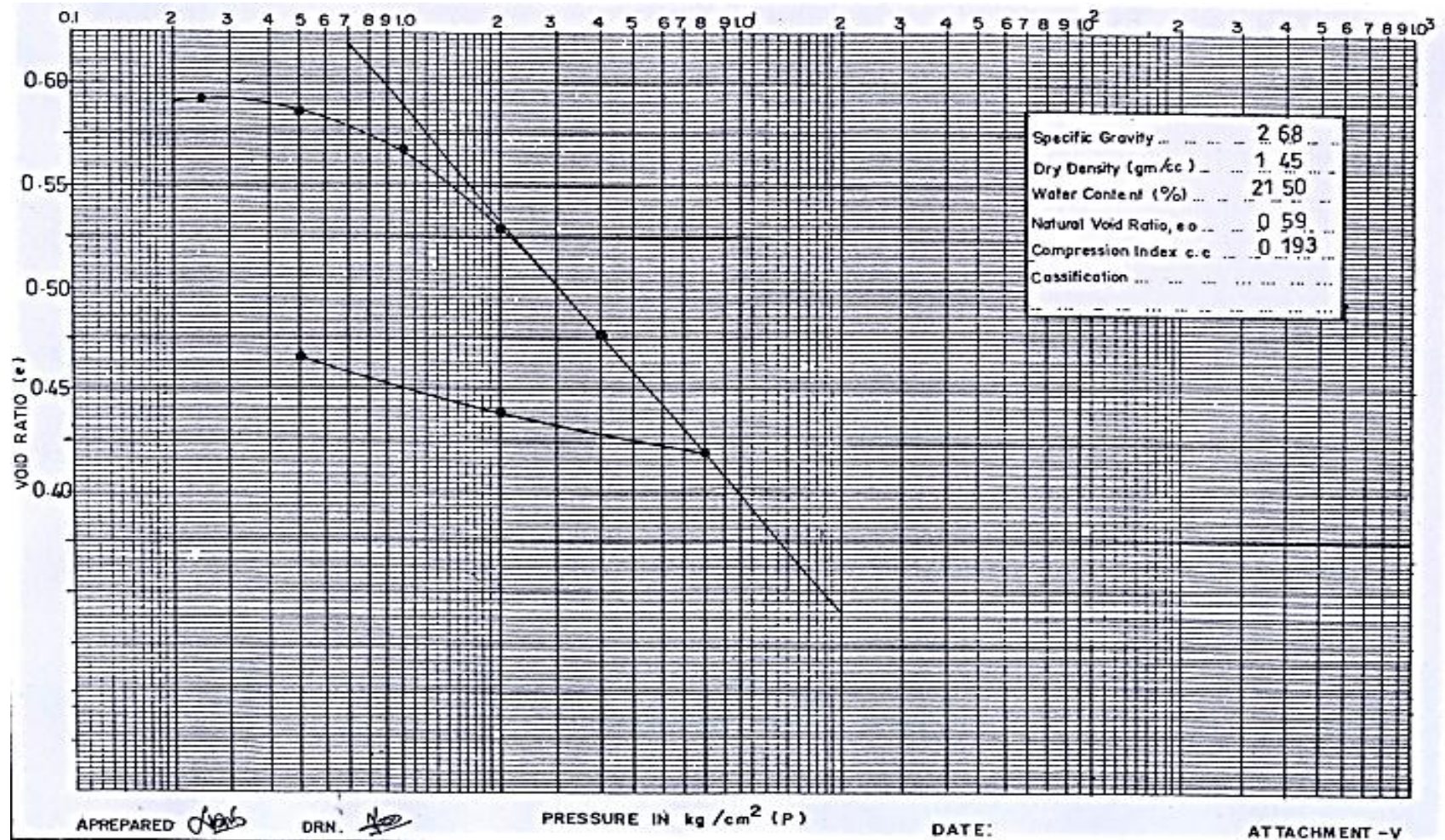

APPENDIX 3 GEO-PROPERTIES AND CORRELATIONS

Unit weight from SPT

Unit weight of a soil mass is the ratio of the total weight of soil to the total volume of soil.

Unit Weight, γ , is usually determined in the laboratory by measuring the weight and volume of a relatively undisturbed soil sample obtained from a brass ring. Measuring unit weight of soil in the field may consist of a sand cone test, rubber balloon or nuclear densiometer.

Empirical values for γ , of granular soils based on the standard penetration number, (from Bowels, *Foundation Analysis*).

SPT Value/ N-Value	γ (lb/ft ³)
0 - 4	70 - 100
4 - 10	90 - 115
10 - 30	110 - 130
30 - 50	110 - 140
>50	130 - 150

Empirical values for γ , of cohesive soils based on the standard penetration number, (from Bowels, *Foundation Analysis*).

N-Value	γ_{sat} (lb/ft ³)
0 - 4	100 - 120
4 - 8	110 - 130
8 - 32	120 - 140

Typical Soil Characteristics (from Lindeburg, *Civil Engineering Reference Manual for the PE Exam, 8th ed.*)

Soil Type	γ (lb/ft ³)	γ_{sat} (lb/ft ³)
Sand, loose and uniform	90	118
Sand, dense and uniform	109	130
sand, loose and well graded	99	124
Sand, dense and well graded	116	135
glacial clay, soft	76	110
glacial clay, stiff	106	125

Typical Values of Soil Index Properties (from NAVFAC 7.01)

Soil Type	γ (lb/ft ³)	γ_{sub} (lb/ft ³)
Sand; clean, uniform, fine or medium	84 - 136	52 - 73
Silt; uniform, inorganic	81 - 136	51 - 73
Silty Sand	88 - 142	54 - 79
Sand; Well-graded	86 - 148	53 - 86
Silty Sand and Gravel	90 - 155	56 - 92
Sandy or Silty Clay	100 - 147	38 - 85
Silty Clay with Gravel; uniform	115 - 151	53 - 89
Well-graded Gravel, Sand, Silt and Clay	125 - 156	62 - 94
Clay	94 - 133	31 - 71
Colloidal Clay	71 - 128	8 - 66
Organic Silt	87 - 131	25 - 69
Organic Clay	81 - 125	18 - 62

Typical Soil Characteristics (from Lindeburg, *Civil Engineering Reference Manual for the PE Exam, 8th ed.*)

Soil Type	γ (lb/ft ³)	γ_{sat} (lb/ft ³)
Sand, loose and uniform	90	118
Sand, dense and uniform	109	130
sand, loose and well graded	99	124
Sand, dense and well graded	116	135
glacial clay, soft	76	110
glacial clay, stiff	106	125

Angle of Internal Friction from SPT

Angle of internal friction for a given soil is the angle on the graph (Mohr's Circle) of the shear stress and normal effective stresses at which shear failure occurs.

Angle of Internal Friction, ϕ , can be determined in the laboratory by the *Direct Shear Test* or the *Triaxial Stress Test*.

Typical relationships for estimating the angle of internal friction, ϕ , are as follows:

Empirical values for ϕ , of granular soils based on the standard penetration number, (from Bowels, *Foundation Analysis*).

N-Value	ϕ (degrees)
0	25 - 30
4	27 - 32
10	30 - 35
30	35 - 40
50	38 - 43

Relationship between ϕ , and standard penetration number for sands, (from Peck 1974, *Foundation Engineering Handbook*).

N-Value	Density of Sand	ϕ (degrees)
<4	Very loose	<29
4 - 10	Loose	29 - 30
10 - 30	Medium	30 - 36
30 - 50	Dense	36 - 41
>50	Very dense	>41

Relationship between ϕ , and N-value for sands, (from Meyerhof 1956, *Foundation Engineering Handbook*).

N-Value	Density of Sand	ϕ (degrees)
<4	Very loose	<30
4 - 10	Loose	30 - 35
10 - 30	Medium	35 - 40
30 - 50	Dense	40 - 45
>50	Very dense	>45

Bearing Capacity factor from Angel of Internal Friction

Bearing capacity is the ability of the underlying soil to support the foundation loads without shear failure.

Bearing capacity factors are empirically derived factors used in a bearing capacity equation that usually correlates with the angle of internal friction of the soil.

Terzaghi's Bearing Capacity Factors

ϕ	N_c	N_q	N_γ
0	5.7	1	0
5	7.3	1.6	0.5
10	9.6	2.7	1.2
15	12.9	4.4	2.5
20	17.7	7.4	5
25	25.1	12.7	9.7
30	37.2	22.5	19.7
34	52.6	36.5	35.0
35	57.8	41.4	42.4
40	95.7	81.3	100.4
45	172.3	173.3	297.5

Meyerhof Bearing Capacity Factors

ϕ	N_c	N_q	N_γ
0	5.14	1.0	0.0
5	6.5	1.6	0.07
10	8.3	2.5	0.37
15	11.0	3.9	1.1
20	14.8	6.4	2.9
25	20.7	10.7	6.8
30	30.1	18.4	15.7
32	35.5	23.2	22.0
34	42.4	29.4	31.2
36	50.6	37.7	44.4
38	61.4	48.9	64.1
40	75.3	64.2	93.7
42	93.7	85.4	139.3
44	118.4	115.3	211.4

Bearing Capacity Factors for Deep Foundations

Meyerhof Values of N_q For Driven and Drilled Piles

ϕ	Driven	Drilled
20	8	4
25	12	5
28	20	8
30	25	12
32	35	17
34	45	22
36	60	30
38	80	40
40	120	60
42	160	80
45	230	115

Cohesion of Soil

Cohesive soils are clay type soils. Cohesion is the force that holds together molecules or like particles within a soil. Cohesion, c , is usually determined in the laboratory from the *Direct Shear Test*. Unconfined Compressive Strength, S_{uc} , can be determined in the laboratory using the *Triaxial Test* or the *Unconfined Compression Test*.

There are also correlations for S_{uc} with shear strength as estimated from the field using *Vane Shear Tests*. $c = S_{uc}/2$

Where:

c = cohesion, kN/m^2 (lb/ft^2), and

S_{uc} = unconfined compressive strength, kN/m^2 (lb/ft^2).

Guide for Consistency of Fine-Grained Soil,

N-value	Estimated Consistency	S_{uc} (tons/ft ²)
<2	Very Soft	<0.25
2 - 4	Soft	0.25 - 0.50
4 - 8	Medium	0.50 - 1.0
8 - 15	Stiff	1.0 - 2.0
15 - 30	Very Stiff	2.0 - 4.0
>30	Hard	> 4

Empirical Values for Consistency of Cohesive Soil, (from Foundation Analysis, Bowels)

N-value	Estimated Consistency	S_{uc} (kips/ft ²)
0 - 2	Very Soft	0 - 0.5
2 - 4	Soft	0.5 - 1.0
4 - 8	Medium	1.0 - 2.0
8 - 16	Stiff	2.0 - 4.0
16 - 32	Very Stiff	4.0 - 8.0
>32	Hard	>8

Typical Strength Characteristics (from Lindeburg, *Civil Engineering Reference Manual for the PE Exam, 8th ed.*)

USCS Soil Group	c , as compacted (lb/ft^2)	c , saturated (lb/ft^2)
GW	0	0
GP	0	0
GM	-	-
GC	-	-
SW	-	-
SP	-	-
SM	1050	420
SM-SC	1050	300
SC	1550	230
ML	1400	190
ML-CL	1350	460
CL	1800	270
OL	-	-
MH	1500	420

Factor of Safety

Foundation Analysis by Bowles has good recommendations for safety factors. He evaluates uncertainties and assigns a factor of safety by taking into account the following:

1. Magnitude of damages (loss of life and property damage)
2. Relative cost of increasing or decreasing the factor of safety
3. Relative change in probability of failure by changing the factor of safety
4. Reliability of soil data
5. Construction tolerances
6. Changes in soil properties due to construction operations
7. Accuracy (or approximations used) in developing design/ analysis methods

Typical values of customary safety factors, F.S., as presented by Bowles.

Failure Mode	Foundation Type	F.S.
Shear	Earthwork for Dams, Fills, etc.	1.2 - 1.6
Shear	Retaining Walls	1.5 - 2.0
Shear	Sheetpiling, Cofferdams	1.2 - 1.6
Shear	Braced Excavations (Temporary)	1.2 - 1.5
Shear	Spread Footings	2 - 3
Shear	Mat Footings	1.7 - 2.5
Shear	Uplift for Footings	1.7 - 2.5
Seepage	Uplift, heaving	1.5 - 2.5
Seepage	Piping	3 - 5

Other customary factors of safety, F.S., used are:

- 1.5 for retaining walls overturning with granular backfill
- 2.0 for retaining walls overturning with cohesive backfill
- 1.5 for retaining walls sliding with active earth pressures
- 2.0 for retaining walls sliding with passive earth pressures

Lateral Earth Pressure Coefficient for Soils

Piles

- NAVFAC: 1.0 - 1.5 for a single displacement pile in compression
- USACE: 1.0 - 2.0 for compression piles in sand that are not pre-bored, jetted or vibrated
1.0 for same conditions except silt
higher values are for displacement piles
- Broms: 0.5 - 1.0 for low density to high density steel
1.0 - 2.0 low density to high density concrete
1.5 - 4.0 low density to high density timber
- Bowles: 0.6 - 1.25. Lower values for silty sands, and higher values for other soils
- Nordlund: uses charts to identify the value for lateral earth pressure coefficients, k , based on the angle of internal friction, ϕ . Ranges from 0.25 to 1.2

Mansure & Hunter: 1.0 - 1.3 for steel pipe piles
 1.4 - 1.9 for H piles
 1.45 - 1.6 for precast concrete piles

Retaining Walls

$K = (1 - \sin\phi)/(1 + \sin\phi)$ for active earth pressures
 $K = (1 + \sin\phi)/(1 - \sin\phi)$ for passive earth pressures
 $K = 1 - \sin\phi$ for at-rest earth pressures
 where ϕ = angle of internal friction of the soil (degrees)

Young's Modulus of Soil

The modulus of elasticity or Young's modulus of a soil is an elastic soil parameter most commonly used in the estimation of settlement from static loads.

Young's soil modulus, E_s , may be estimated from empirical correlations, laboratory test results on undisturbed specimens and results of field tests. Laboratory tests that may be used to estimate the soil modulus are the triaxial unconsolidated undrained compression or the triaxial consolidated undrained compression tests. Field tests include the plate load test, cone penetration test, standard penetration test (SPT) and the pressuremeter test. Empirical correlations summarized from USACE EM 1110-1-1904 is presented below:

$E_s = K_c C_u$
 where: E_s = Young's soil modulus (tsf)
 K_c = correlation factor
 C_u = undrained shear strength, tsf

Typical Elastic Moduli of soils based on soil type and consistency/ density, (from USACE, *Settlement Analysis*).

Soil	E_s (tsf)
very soft clay	5 - 50
soft clay	50 - 200
medium clay	200 - 500
stiff clay, silty clay	500 - 1000
sandy clay	250 - 2000
clay shale	1000 - 2000
loose sand	100 - 250
dense sand	250 - 1000
dense sand and gravel	1000 - 2000
silty sand	250 - 2000

APPENDIX- 4

LAB REPORT FORMAT

1. All students must have a same colored printed **cover page**. The design of cover page is provided with the lab manual. Students have to compose only the course teacher's name and designation and their information.
2. An **index** is provided. It should be printed and set after the cover page. Table may be filled up by pen during each submission after test.
3. Each report must have a common printed **top page**. Only the experiment name and no. and the date may be filled up by pen. A top page design is provided.
4. **A4 papers** have to be used for preparing the lab report. Writing should be done with **pen**. Pencil may be used for any kind of sketch.



CE 442

Geotechnical Engineering Session III (Foundation Design Manual)



Submitted to Course Teacher(s)

Name

Designation

&

Name

Designation

Submitted by Student

Name

Student's ID.....

Year/ Semester.....

Group.....

INDEX

Expt. No.	Topic	Date of Submission	Signature	Comments	Page No.



CE 442

Geotechnical Engineering Sessional-I

(Lab Report)

Experiment No. :
Experiment Name :

Date of Performance :
Date of Submission :

Submitted to Course Teacher(s)
Name
Designation
&
Name
Designation

Submitted by Student
Name
Student's ID.....
Year/ Semester.....
Group.....

Appendix 5

Lab Instructions

1. All students must have to be present at design class just in time.
2. All students must have to submit the lab report just after the entrance and before the class start.
3. Lab reports have to be submitted serially according to Student's ID.
4. All students must have to bring the lab manual in the class.
5. Students have to bring design pad, pen pencil, scale and calculator in every class.

