



CE 102

Computer Aided Drafting

(Software package: AutoCAD 2007)



**Department of Civil Engineering
Ahsanullah University of Science and Technology**

November, 2017

Preface

CAD stands for Computer Aided Drafting. Like all other technical fields, in drafting computer have brought revolution. CAD has not only reduced the time spent for drafting to a fraction, of that the same produced by hand drawings, but also any revisions in the drawing can be done quickly without having to redraw everything. Moreover, different views, such as front view, side views etc. can be easily created from the drawing. To use CAD software efficiently, it is necessary to know all drafting tools to have a good control over the work. This lab manual intends to guide the students to know the fundamental tools to create, modify and manage documentation effectively through a skillful way.

Writing a manual is an all-encompassing and time consuming project and author would like to thank Prof. Dr. Md. Mahmudur Rahman for his proper guidance and also acknowledge AutoCAD User Guide as the major source of the information presented in this manual.

Prepared By

Debasish Sen

Department of Civil Engineering
Ahsanullah University of Science and Technology

Updated By

Sudipta Dey Tirtha

Department of Civil Engineering
Ahsanullah University of Science and Technology

Nasima Sultana

Department of Civil Engineering
Ahsanullah University of Science and Technology

Index

	Page No.
Chapter 1. Computer Aided Drafting (CAD)	1
Chapter 2. Drawing, Editing and Dimensioning.....	2
Chapter 3. Plan, Elevation and Section of a Building.....	40
Chapter 4. Reinforcing Detailing	44
Chapter 5: Plan, Section and Elevation of Slab Culvert	49
Chapter 6: Plan, Elevation and Section of an Underground Water Reservoir.....	51
Assignment	53
References.....	62

Table of Figures

	Page No.
Figure 1.1: 2D User Interface	1
Figure 2.1: List of all tool bar	2
Figure 2.2: X-Y Co-ordinate.....	4
Figure 2.3: Co-ordinate System	5
Figure 2.4: Cartesian Co-ordinate System.....	5
Figure 2.5: Polar Co-Ordinate System.....	5
Figure 2.6: The Pickbox.....	6
Figure 2.7: The Window selection box is shown as a rectangle with a solid line	6
Figure 2.9: The Crossing Window selection box is shown as a rectangle with a broken line..	7
Figure 2.10: Drawing Unit Selection	7
Figure 2.11: Direction Control.....	9
Figure 2.12: Available snap options.	11
Figure 2.13: Start point and end point of arc	13
Figure 2.14: Polygon.....	14
Figure 2.15: Ellipse.....	15
Figure 2.16: Hatch Properties Manager	16
Figure 2.17: Hatching options	17
Figure 2.18: Choosing Area to be Hatched.....	17
Figure 2.19: Island Style	18
Figure 2.20: A dining table as block.....	18
Figure 2.21: Chamfering	22
Figure 2.22: Linear Dimension	25
Figure 2.23: Dimensioning Along Align Plane	28
Figure 2.24: Selecting Line Color.....	33
Figure 2.25: Selecting Line Type	34
Figure 2.26: Loading Line Type	34
Figure 2.27: Selecting Line Type Scale	37
Figure 3.1: Plan of a residential building.....	411
Figure 3.2: Front view of the building	422
Figure 3.3: Section 1-1.....	433
Figure 4.1: Wall Footing and Column Footing.....	456

Figure 4.2: Reinforcement details of roof slab	467
Figure 4.3: Longitudinal and Cross section of beam	478
Figure 4.4: Reinforcement detailing of stair	49
Figure 5.1: Plan of Culvert	49
Figure 5.2: Sectional Views of Culvert.....	50
Figure 6.1: Plan of underground reservoir.....	51
Figure 6.2: Section A-A.....	52

Chapter 1 Computer Aided Drafting (CAD)

- ✚ The use of computer technology for the process of design documentation (i.e. drafting).
- ✚ CAD may be used to draft in 2D or 3D space.

2D User Interface (AutoCAD 2007)

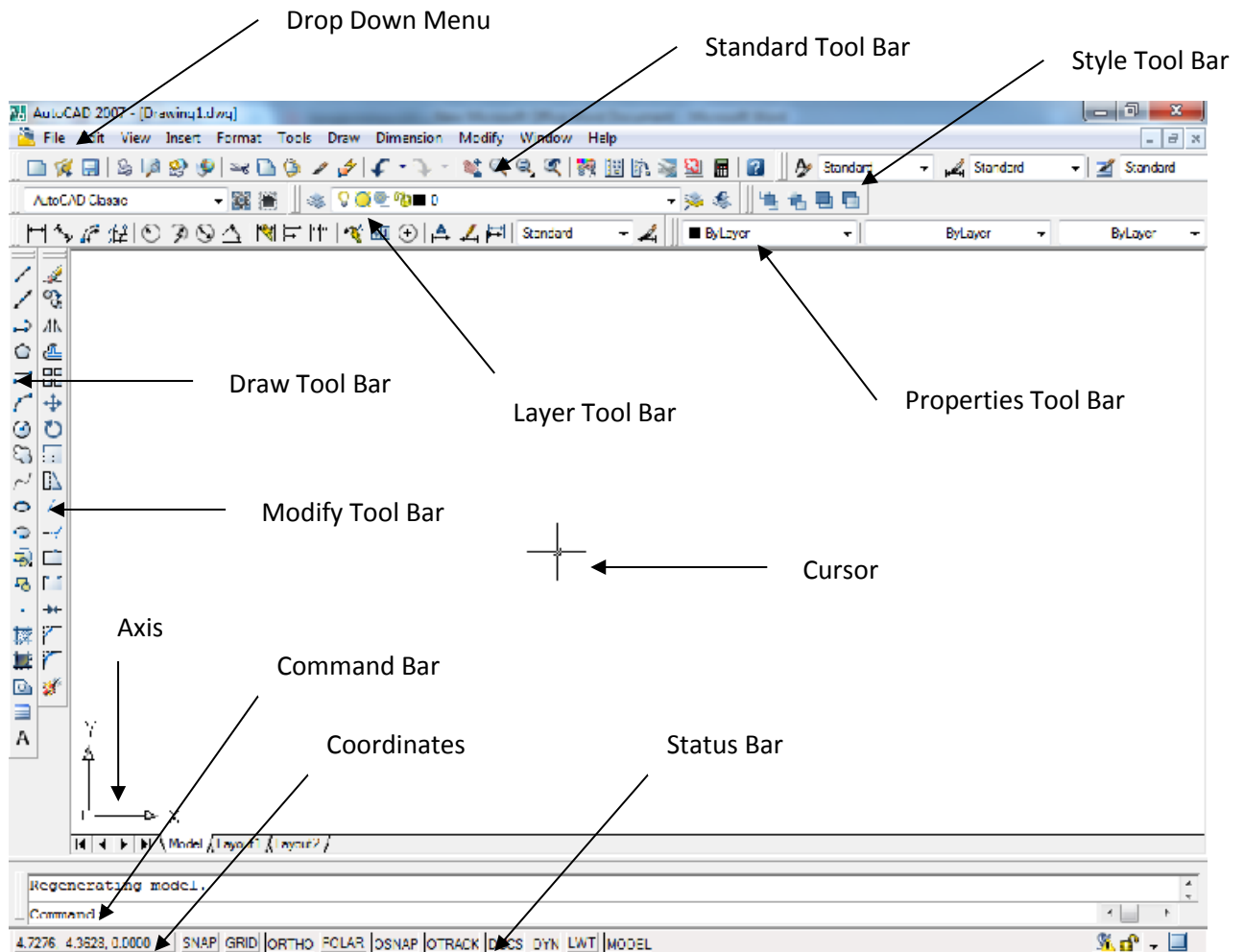


Figure 1.1: 2D User Interface

Chapter 2

Drawing, Editing and Dimensioning

Drop-Down Menu: All options of AutoCAD can be accessed from this menu.

Standard Tool Bar: Shows copy, cut, paste, save, zoom icons.

Style Tool Bar: Shows current text style, dimension style, table style.

Layer Tool Bar: Shows current layer name.

Properties Tool Bar: Shows color, line type, line weight.

Draw Tool Bar: Shows line, rectangle, circle icons.

Modify Tool Bar: Shows modification icons.

Command Line: Shows activated command.

Frequently Asked Questions

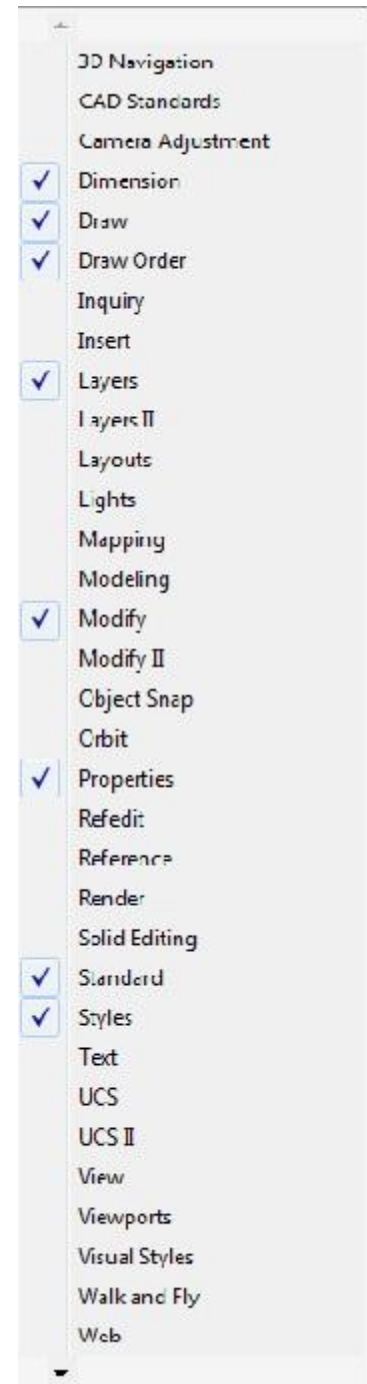
How to bring a toolbar on user interface?

- ✚ Right click on any toolbar (i.e. Draw)
- ✚ Select required toolbar (i.e. Dimension) from list (Shown in the figure)
- ✚ Set the position of the toolbar (click at the double line border and drag it)

How to Change workspace from 3D to 2D or vice versa?

- ✚ Press “Tools”
- ✚ Select “Workplaces”
- ✚ Select “ 3D modeling” or “AutoCAD classic”

Figure 2.1: List of all tool bar



How to start and terminate commands in AutoCAD?

- ✚ Three ways to start a command (i.e. Line)
 1. From Drop Down Menu (Draw > Line)
 2. From Command line with short key (Type “ 1 ” in the command line and press “Enter”)
 3. From Toolbar (Click on the line command icon on the draw toll bar)
- ✚ Press “Esc” button on keyboard to terminate any command.

How to start and complete a drawing?

- ✚ Set drawing unit (Format > Unit)
- ✚ Create text styles (Format > Text Style)
- ✚ Create dimension style (Format > Dimension Style)
- ✚ Create new layers (Format > Layer)
- ✚ Draw and modify objects (Use Draw and Modify toolbar or menu)
- ✚ Provide dimensions (Use dimension toolbar or menu)
- ✚ Write texts (Use draw toolbar or menu)

How to save a file?

- ✚ Click “File” on Drop Down Menu bar
- ✚ Click “Save as”
- ✚ Select “Drive” to save
- ✚ Rename file name only (keep **.dwg** as extension)
- ✚ Press “Save”

Or

- ✚ Press “Ctrl” + S
- ✚ Select “Drive” to save
- ✚ Rename file name only (keep **.dwg** as extension)
- ✚ Press “Save”

How to plot a file?

- ✚ Press “Ctrl” + P
- ✚ Select printer name / DWG to PDF.pc3 (Use “Printer name” to print and DWG to PDF to publish as pdf)
- ✚ Select paper size
- ✚ Check “Fit to paper”
- ✚ Check “Center the Plot”
- ✚ Press more option (if necessary)
 - ✓ Select Plot style table (None is ok. Select Monochrome.ctb for black and white print)
 - ✓ Select quality
 - ✓ Select drawing orientation
- ✚ Press “Preview”
- ✚ Press “Plot”

Why one may use polyline?

Polylines have some unique qualities that make them very useful:

- ✚ Polylines drawn under one single command can be selected by single click.
- ✚ They can have width (constant or varying)
- ✚ They can consist of arcs and lines
- ✚ They can be edited
- ✚ They can be joined together.
- ✚ They can be exploded into individual segments
- ✚ Especially useful for 3D drawing

How to cancel the last command?

- ✚ Press “undo” button on standard toolbar
- Or
- ✚ Press “Ctrl” + “Z”



The X-Y Co-Ordinate System

The UCS Icon

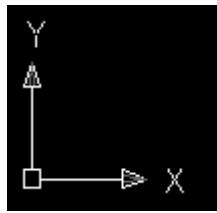


Figure 2.2: X-Y Co-ordinate

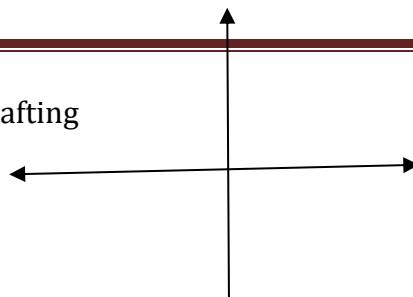
In the bottom left corner of the AutoCAD drawing window you will see a symbol like one shown in top. This is called the UCS (User Co-ordinate System) icon and it is there to remind you which is the X axis and which is the Y axis. In AutoCAD, there are two co-ordinate systems:

- ✚ World Co-ordinate System: A fixed system.
- ✚ User Co-ordinate System: A movable system.

You can relocate the user co-ordinate system using any of these methods:

- ✚ Move the UCS by defining a new origin.
- ✚ Align the UCS with an existing object or with the current viewing direction.
- ✚ Rotate the current UCS around any of its axes.
- ✚ Restore a saved UCS.

Using Co-ordinate



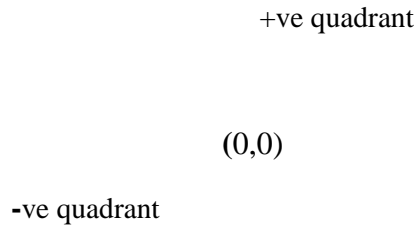


Figure 2.3: Co-ordinate System

Co-ordinates fall into two types, namely Cartesian and Polar. In addition, these two co-ordinates types come in two distinct flavors. They can be absolute and relative.

Cartesian Co-ordinates

Despite the fancy title, the Cartesian co-ordinate system is the standard co-ordinate system. The position of a point can be described by the distance from the axes, X and Y. This results in a simple point description using two numbers separated by a comma e.g. 34.897, 45.473.

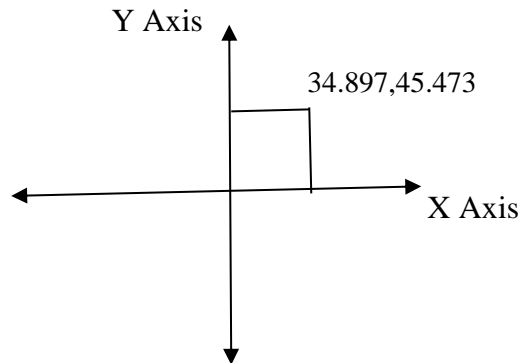


Figure 2.4: Cartesian Co-ordinate System

Polar Co-ordinate System

Polar co-ordinates achieve the same result i.e. the description of the position of a point. The main difference is that polar co-ordinates use one distance and one angle to describe the position of a point rather than the two distances in the Cartesian system. The distance and angle measured relative to an origin. This results in a point description which looks like this 34.897<30 where the first figure is the distance and the second is the angle.

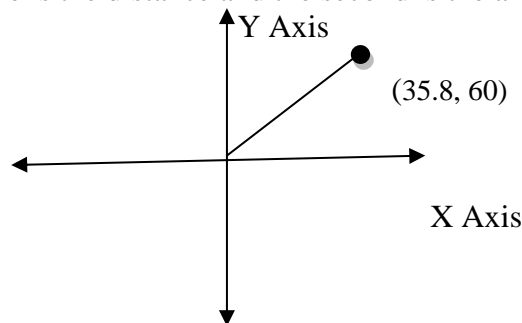


Figure 2.5: Polar Co-Ordinate System

Object Selection

Before you start to use your AutoCAD commands, you need to know something about selecting objects. All of the modify commands require that you make one or more object

selections. AutoCAD has wide range of tools which are designed to help you select just the object you need.

1. Selecting Object by Picking

Perhaps the most obvious way to select an object is simply to pick it. To select an object, place the pick-box over a part of the object and left click the mouse. When the object has been picked, it is highlighted in a dashed line to show that it is part of the current selection and the command line reports “1 found”.

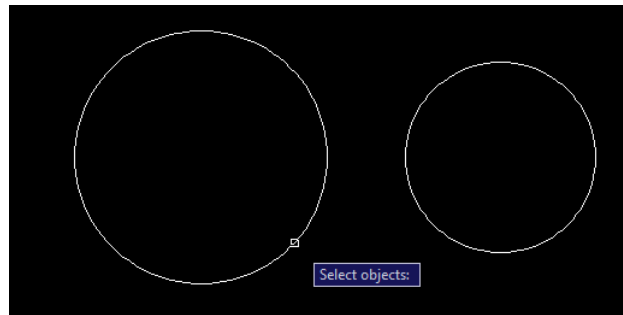


Figure 2.6: The Pickbox

2. Window Selection

The window option is invoked by typing **W** in response to the “select objects” prompt. Window allows you to define a rectangle using two points in exactly the same way as the RECTANGLE command. Once all objects which lie within the window will be selected.

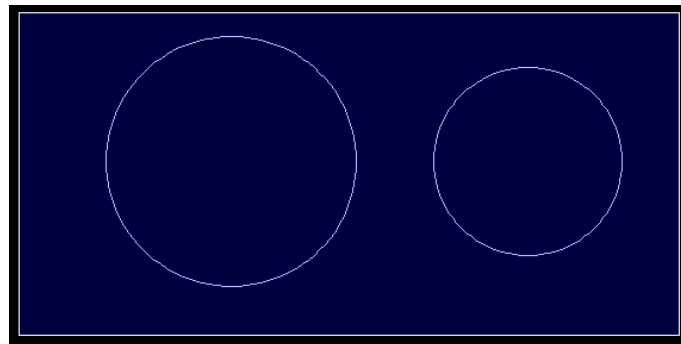


Figure 2.7: The Window selection box is shown as a rectangle with a solid line

3. Crossing Window Selection

The crossing window option is invoked by typing **C** at the “Select objects” prompt and is variation of the Window command. The command sequence is exactly the same but objects are selected which lie within the window and those which cross the window border.

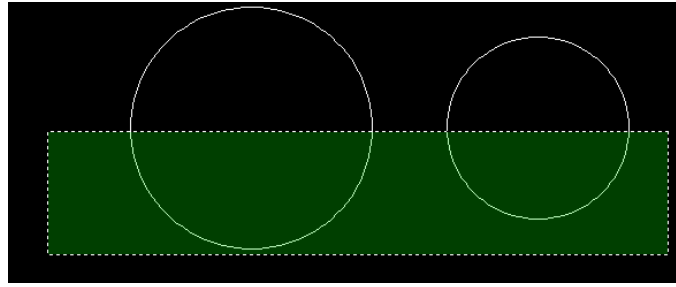


Figure 2.8: The Crossing Window selection box is shown as a rectangle with a broken line

4. Selecting All Object

The All option is invoked by typing ALL at the “Select objects” prompt. You can use this option to select all the objects in the drawing, no picking is required. Objects on Locked or Frozen layers are not selected but objects on layers which are simply turned off are selected.

5. Using Previous Selection

AutoCAD always remembers the last selection set you defined. This is very useful because you may need to make a number of changes using different commands to the same group of objects. In order to reselect the last selection, you can use the previous selection. The previous option is invoked by typing P at the “Select objects” prompt.

6. Selecting the Last Object

You can select the last object created by entering L at the “Select objects” prompt.

Units and Scales

Introduction:

Among the most important concepts that newcomers to AutoCAD need to get to grips with are those of drawing scale and units. You cannot start crating sensible drawings with AutoCAD until you are familiar with scale, units and commands you use to control them.

Units Control:

Command line: Type UN (units) and press Enter

Format menu: Units

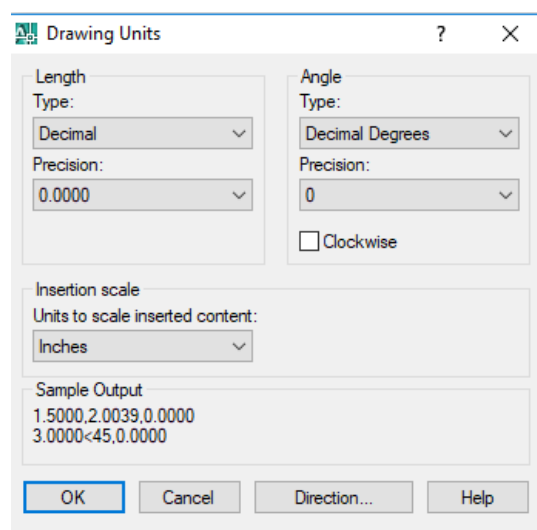


Figure 2.9: Drawing Unit Selection

Toolbar: none

When you start the Units command, the first thing you see is the Drawing Units dialogue box. The dialogue box is divided into four main sections:

Length: You can see from the dialogue box that there are five different linear unit types for you to choose from, one of which is “Decimal”, the default. The table shows the effect of the different unit settings on two drawing unit values to give you an idea how various settings must be used along with a brief description.

Table 1: The effect of different unit settings on two drawing unit values with description

Unit type	1.5 Drawing Units	1500 Drawing Units	Description
Decimal	1.5000	1500.0000	Metric or SI units
Scientific	1.5000E+00	1.5000E+03	Decimal value raised to a power
Engineering	0'-1.5000''	125'-0.0000''	Feet and decimal inches
Architectural	0'- 1 ½''	125'-0''	Feet and fractional inches
Fractional	1 ½ ''	1500	Whole numbers and fractions

Notice that when you change the unit type, the co-ordinate display on the status bar changes to show co-ordinates using the current unit type. Units such as “Architectural” and “Engineering” are mainly for AutoCAD users where Feet and inches are still in common use.

Angles: Looking at the Drawing Units dialogue box again, you will notice that there are also five angular unit types. The default is decimal degrees, but there are other options. The table below shows the effect of the different unit types on two angular unit values.

Unit type	12.5 Angular units	180 Angular Units	Description
Decimal Degrees	12.500	180.000	Metric units
Deg/Min/Sec	12d30'0''	180d0'0''	Degrees, Minutes and Seconds
Grads	13.889g	200.000g	400 grads=360 degrees
Radians	.218r	3.142r	2 Pi radians= 360 degrees
surveyor	N77d30'0''E	W	Compass bearings

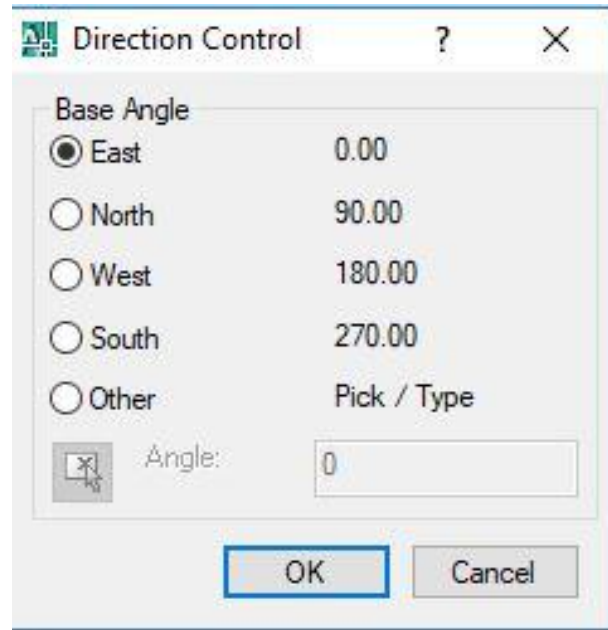


Figure 2.10: Direction Control

AutoCAD also allows you to control the direction in which angular units are measured and the position of the start angle. AutoCAD starts with the zero angle at the 3 o'clock position (East) with angles increasing in an anti-clockwise direction. This case may be changed for other modes.

Drawing Units for Design Center Blocks: Allows you to assign a specific unit to the drawing so that when blocks are inserted via the AutoCAD Design Centre, they will automatically be scaled.

Sample output: Gives you a preview of the drawing units as they will be displayed using the current settings.

Unit Precision

The Drawing Units dialogue box can also be used to set the precision of linear and angular units. By default, AutoCAD sets the linear unit precision to four places of decimal, so appear in the form 0.0000. Angular unit precision is set to whole degrees only. To change the precision with which linear and angular values are displayed, simply click the down arrow against the appropriate drop-down list and select the number of decimal places required. The default setting of four decimal places is usually adequate for linear units. It is, however, often necessary to change the precision for angular units. Working in whole degrees does not usually give an adequate level of detail for many drawing functions. However, you do not need to change the precision of either linear or angular units unless you have a specific reason for doing so.

Changing the unit precision does not make your drawing more accurate, it just means that the co-ordinate display on the status bar and the results from the various inquiry commands will be displayed with a higher degree of precision. The accuracy of your drawing will be determined by the values you enter for the size of objects when you draw and edit them and by the correct use of the various object snaps and drawing aids.

Zoom (Standard Tool Bar) (z)

1. Pan real time: Move display.
2. Zoom real time: Increase or decrease display size. (Use mouse scroll as alternative)
3. Zoom window: Enlarge the part of the drawing
4. Zoom previous: Returns to the last Zoom view.



N.B.: To bring all drawings on screen use **zoom all (Z← A←)**.

Status Bar

1. **ORTHO** (Ortho mode)
 - ✚ Click on “ORTHO” button on Status bar or Press F8
 - ✚ Enforces to draw horizontal or vertical lines only
2. **OSNAP** (Object snap)
 - ✚ Click on “OSNAP” button on Status bar or Press F3
 - ✓ Right click on “OSNAP” button on Status bar
 - ✓ Press “Setting”
 - ✓ Check desired object snap options
 - ✓ Press “ok”
 - ✚ Helps to snap (grip) different points during drafting

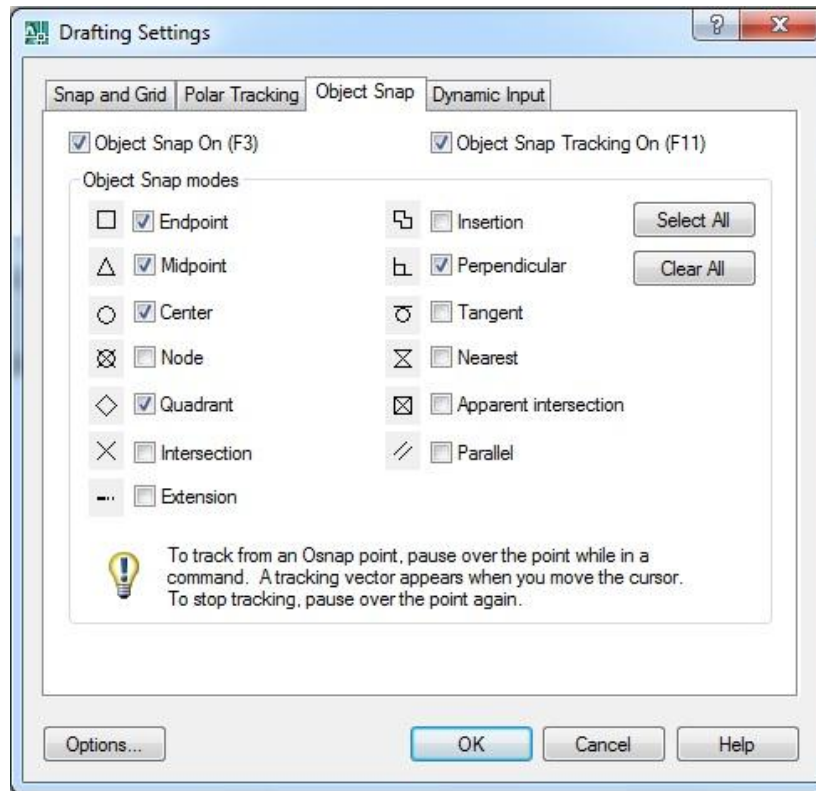


Figure 2.11: Available snap options.

3. **DYN (Dynamic Input)**

- ✚ Click on “DYN” button on Status bar or Press F12
- ✚ Shows command line with cursor during execution of any command

4. **LWT (Line weight)**

- ✚ Click on “LWT” button on Status bar
- ✚ Shows line thickness

Draw Toolbar



1. Line (l)

a. By picking two points

- ✚ Specify first point (click at any point)
- ✚ Specify next point (click at any point)

Or

- b. By direct distance entry
 - ✚ Specify first point (click at any point).
 - ✚ Input length (type length of the line)
 - ✚ Press “Tab” on the keyboard
 - ✚ Input angle (type angle with the X axis)
 - ✚ Press enter(↵) on the keyboard

Horizontal or vertical line

- ✚ Specify first point (click at any point)
- ✚ Press “ORTHO” in status bar or press F8 on keyboard.
- ✚ Input length (type length of the line) [Keep the cursor appropriately]
- ✚ Press enter(↵) on the keyboard

2. Rectangle (rec)

- a. By picking two points
 - ✚ Specify first corner point (click at any point)
 - ✚ Specify other corner point (click at any point)

Or

- b. By direct distance entry
 - ✚ Specify first corner point (click at any point)
 - ✚ Input length along X (type length of the rectangle)
 - ✚ Press “Tab” on keyboard
 - ✚ Input width along Y (type width of the rectangle)
 - ✚ Press enter(↵) on the keyboard

3. Circle (c)

- ✚ Specify center point (click at any point)
- ✚ Input radius of the circle (type radius of the circle)
- ✚ Press enter(↵) on the keyboard

Or

- ✚ Specify center point (click at any point)
- ✚ Type d
- ✚ Press enter(↵) on the keyboard
- ✚ Input diameter of the circle (type diameter of the circle)
- ✚ Press enter(↵) on the keyboard

4. Arc (a)

To draw an arc three points on the arc are necessary. The choice of these points depends on the user or availability of defined points. AutoCAD by default draw arc anticlockwise. So select start and end points properly to get the desired arc shape.

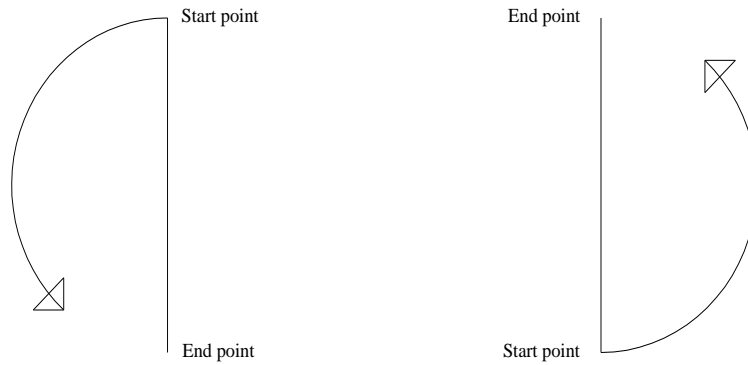


Figure 2.12: Start point and end point of arc

Table 2: Table for available options of arc and its steps

Available options	Steps
Center, Start, End	<ul style="list-style-type: none"> ✚ Type c ✚ Press enter(↵) on the keyboard ✚ Specify center point of the arc (Click at the center point of the desired arc) ✚ Specify start point of the arc (Click at the start point of the desired arc) ✚ Specify end point of the arc (Click at the end point of the desired arc)
Start, center, end	<ul style="list-style-type: none"> ✚ Specify start point of the arc (Click at the start point of the desired arc) ✚ Type c ✚ Press enter(↵) on the keyboard ✚ Specify center point of the arc (Click at the center point of the desired arc) ✚ Specify end point of the arc (Click at the end point of the desired arc)
Start, Center, Angle	<ul style="list-style-type: none"> ✚ Specify start point of the arc (Click at the start point of the desired arc) ✚ Type c ✚ Press enter(↵) on the keyboard ✚ Specify center point of the arc (Click at the center point of the desired arc) ✚ Input angle (Angle of end point with X axis at center)
Start, End, Radius	<ul style="list-style-type: none"> ✚ Specify start point of the arc (Click at the start point of the desired arc) ✚ Type e ✚ Press enter(↵) on the keyboard ✚ Specify end point of the arc (Click at the center point of the desired arc) ✚ Type r

	<ul style="list-style-type: none">✚ Press enter(↵) on the keyboard✚ Input radius. (type radius of the desired arc)
--	---

Special note:

- For simplicity use polyline to draw arc.

5. Donut (do)

- ✚ Input inside diameter (generally zero (0))
- ✚ Press enter(↵) on the keyboard
- ✚ Input outside diameter (choose a value based on your drawing)
- ✚ Press enter(↵) on the keyboard
- ✚ Specify center of donut (click at points where donuts are necessary)

6. Polygon (pol)

- ✚ Input number of sides
- ✚ Specify center of polygon (click at point)
- ✚ Select an option
 - ✓ Inscribed in circle
 - ✓ Circumscribed about circle
- ✚ Input radius of circle

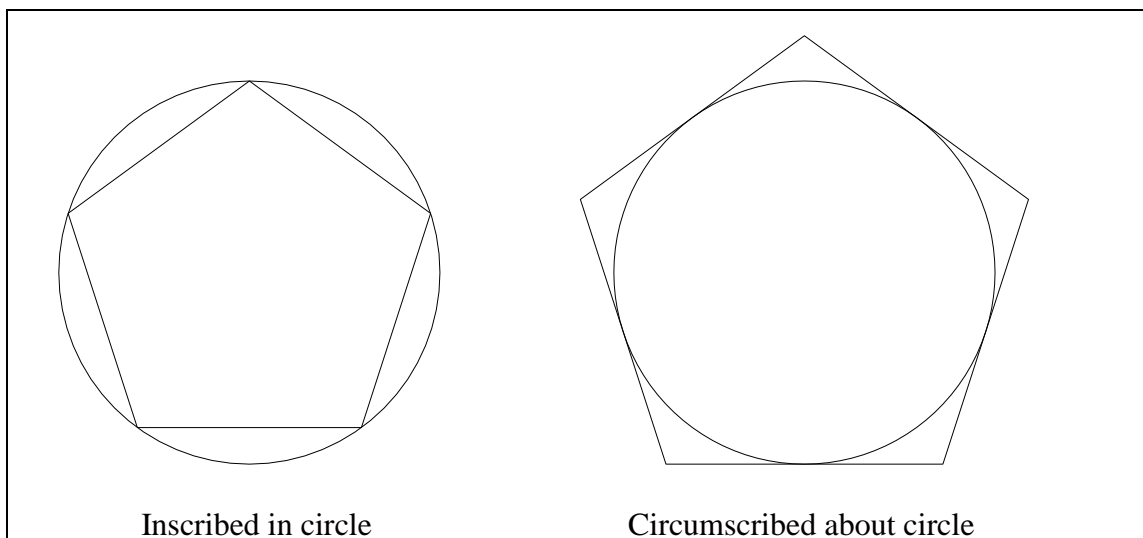


Figure 2.13: Polygon

7. Ellipse (el)

- ✚ Specify first point of major axis (click at point)
- ✚ Specify endpoint of major axis (click at point)
- ✚ Input distance from the midpoint of the first axis to the endpoint of the minor axis

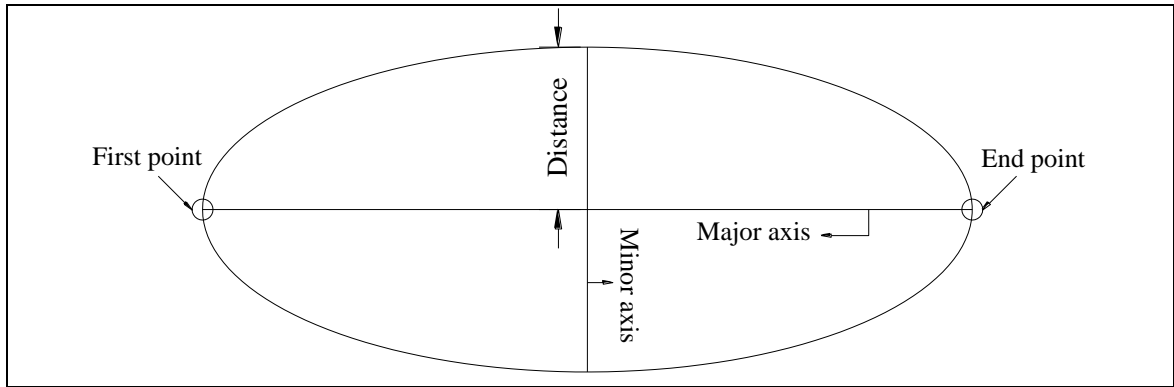
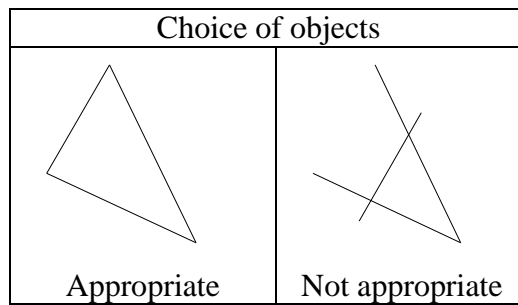


Figure 2.14: Ellipse

8. Region (reg)

- Select objects (lines intersect at end points are appropriate objects)
- Press enter(↵) on the keyboard



9. Hatch (h)

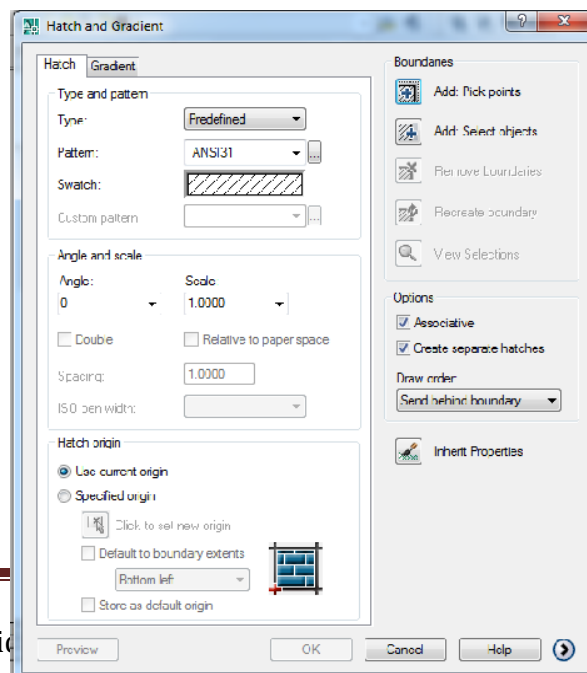


Figure 2.15: Hatch Properties Manager

- ✚ Use predefined type
- ✚ Choose the desired pattern (i.e. concrete, brick etc)
- ✚ Choose angle (Change the orientation of the hatch lines but default is recommended)
- ✚ Input scale value (Large value lightens the hatch and small value densifies hatch)
- ✚ Choose appropriate boundary selection option
 - ✓ Add pick points: Click at any point in a closed boundary (does not work if any gap on the boundary)
 - ✓ Add select objects: Select objects (objects may or may not create closed boundary)
- ✚ Press enter(↵) on the keyboard
- ✚ Choose option
 - ✓ Check “ Associative” option to allow modification of hatch shape with the boundary shape
 - ✓ Check “Create separate hatches” option to create separate hatches in case of multiple boundary selection
- ✚ Press “Preview”
- ✚ Observe hatch created
- ✚ Press enter(↵) on the keyboard
- ✚ If obtain desired hatch press “ok” or Change parameters and repeat from preview.

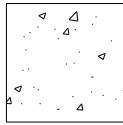
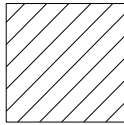
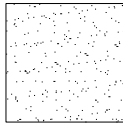
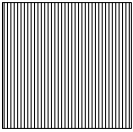
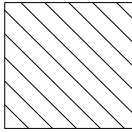
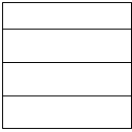
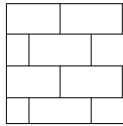
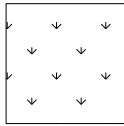
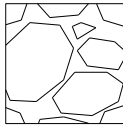
Angle and Scale				Type		
Angle	0	0	0			
				Concrete	Brick	Sand
Angle	45	90	135			
Scale	1	5	10	Brick	Grass	Gravel

Figure 2.16: Hatching options

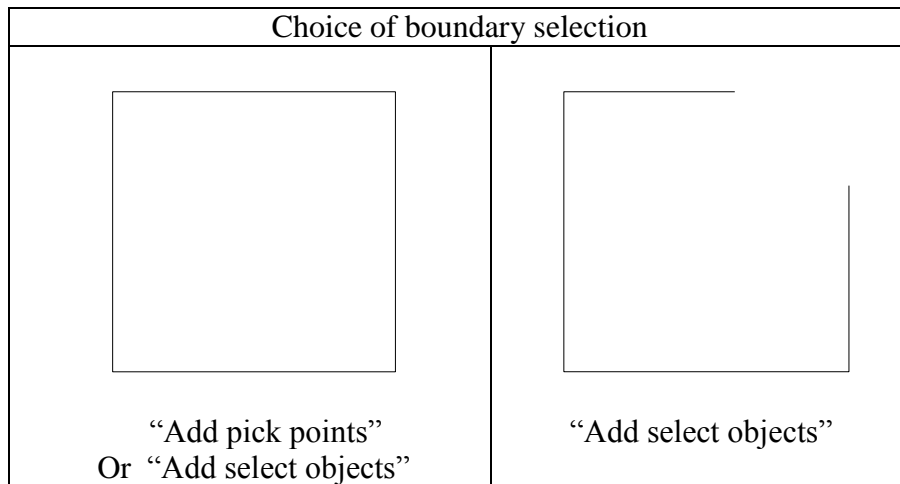


Figure 2.17: Choosing Area to be Hatched

Special Notes:

- One can choose more than one boundary at a time to create hatch (use separate option for convenience).
- One can modify any hatch by double clicking.
- Choose proper island style [if necessary]. Any enclosed area inside the hatch boundary is island.

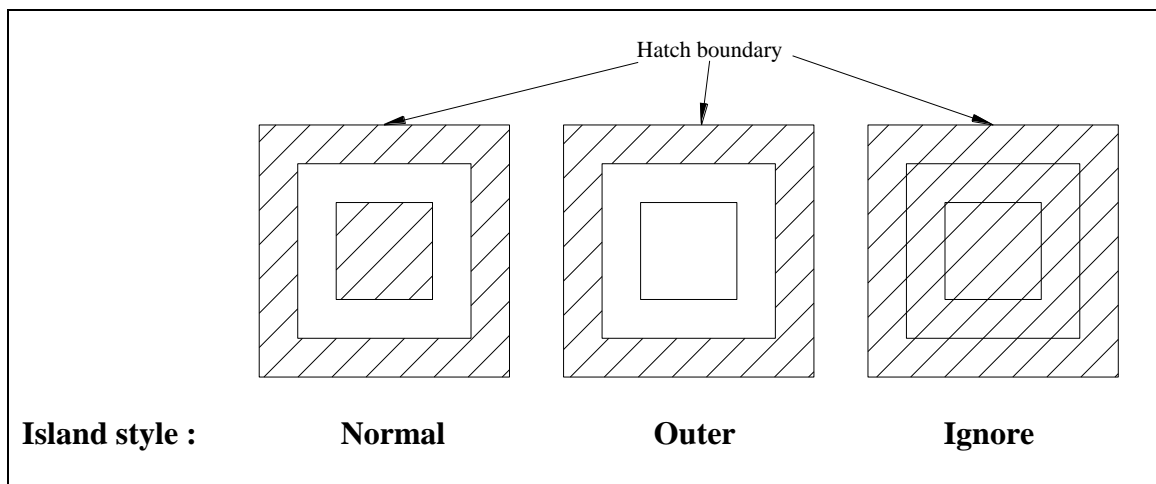


Figure 2.18: Island Style

10. Text (t)

- ✚ Draw small window
- ✚ Select text style and font (if necessary)
- ✚ Choose text height
- ✚ Write on the shaded box
- ✚ Press enter(↵) on the keyboard to go next line (if necessary)
- ✚ Press “ok”

Special Notes:

- One can modify text by double clicking.
- One can underline a sentence or make a word bold etc.
- One can insert symbol (use @ icon)
- One can insert fraction or subscript or superscript.

	Command	Output
Superscript	<ul style="list-style-type: none"> ✓ Type X2^ ✓ Select 2^ ✓ Press “Stack ($\frac{a}{b}$)” icon 	X^2
Subscript	<ul style="list-style-type: none"> ✓ Type X^2 ✓ Select ^2 ✓ Press “Stack ($\frac{a}{b}$)” icon 	X_2
Fraction	<ul style="list-style-type: none"> ✓ Type X/Y ✓ Select X/Y ✓ Press “Stack ($\frac{a}{b}$)” icon 	$\frac{X}{Y}$

11. Block

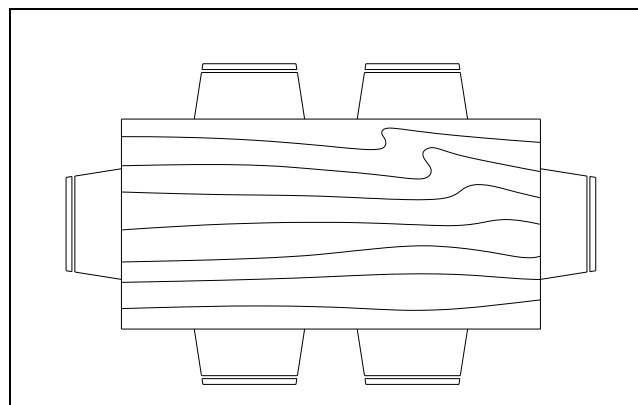


Figure 2.19: A dining table as block

a. Insert block (i)

- ✚ Browse (C:\Program Files \AutoCAD 2007 \Sample\Design center\ House designer)
- ✚ Check explode

- ✚ Press “ok”
- ✚ Specify insertion point for block (click at any point of window)
- ✚ Zoom all to see blocks

b. Make Block (b)

- ✚ Draw an object
- ✚ Define a name to the block
- ✚ Input base point (Press pick point and click at any point closer to the object)
- ✚ Select object (select the desired object to make block)
- ✚ Press enter(↵) on the keyboard
- ✚ Check “Convert to Block”
- ✚ Choose appropriate block unit
- ✚ Press “ok”
- ✚ Keep the file for further use as block

Modify Toolbar



1. Offset (o)

- ✚ Input offset distance (perpendicular distance between parallel lines)
- ✚ Press enter(↵) on the keyboard
- ✚ Select object (only one line can be selected)
- ✚ Specify point on side to offset (select any side of the line)

2. Copy (co or cp)

- ✚ Select object or objects
- ✚ Press enter(↵) on the keyboard
- ✚ Specify the base point
- ✚ Specify second point or input distance (horizontal or vertical or inclined)

3. Move (m)

- ✚ Select object or objects
- ✚ Press enter(↵) on the keyboard
- ✚ Specify the base point
- ✚ Specify second point or input distance (horizontal or vertical or inclined)

4. Rotate (ro)

AutoCAD by default considers anticlockwise rotation as positive. So to rotate clockwise one should assign negative angle.

- ✚ Select object or objects
- ✚ Press enter(↵) on the keyboard

- ✚ Specify the base point
- ✚ Input angle (angle with X axis)

5. Mirror (mi)

- ✚ Select object or objects
- ✚ Press enter(↵) on the keyboard
- ✚ Specify first point of the mirror line
- ✚ Specify second point of the mirror line
- ✚ Press enter(↵) on the keyboard

6. Extend (ex)

- ✚ Select line or lines as boundary edge (Right click mouse to select all lines as boundary edges and skip next step)
- ✚ Press enter(↵) on the keyboard
- ✚ Select end of the object or objects closer to boundary edge to extend

7. Trim (tr)

- ✚ Select line or lines as cutting edge (Right click mouse to select all lines as cutting edges and skip next step)
- ✚ Press enter(↵) on the keyboard
- ✚ Select object or objects to trim

Special Notes:

- Hold “Shift” key to alter trim and extend command.

8. Array (ar)

a. Rectangular array

- ✚ Input number of row and column
- ✚ Input row and column offset (Offset means c/c distance of rows or columns)
- ✚ Input angle of array (if necessary) (indicates the angle of row with positive x axis)
- ✚ Select object
- ✚ Press enter(↵) on the keyboard
- ✚ Press “Preview”
- ✚ Observe the array created
- ✚ If obtain desired array press “accept” otherwise press “Modify” and repeat steps

b. Polar array

- ✚ Specify center point
- ✚ Choose appropriate method of array (i.e. choose any two parameter from total no. of item, angle to fill and angle between item)
- ✚ Input parameter values
 - ✓ Total no. of items: Input number of items to be considered as array element

- ✓ Angle to fill: Input angle to be filled up by the array elements
- ✓ Angle between items: Input angle between array elements at center of the circle.
- ✚ Check/uncheck rotate items as copied (allow/disallow the rotation of array elements)
- ✚ Select object
- ✚ Press enter(↵) on the keyboard
- ✚ Press “Preview”
- ✚ Observe the array created
- ✚ If obtain desired array press “accept” otherwise press “Modify” and repeat steps

9. Scale (sc)

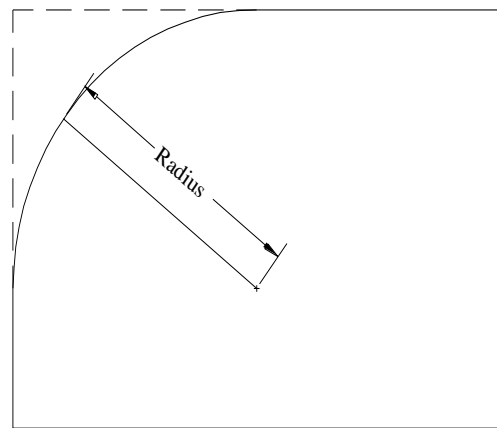
- ✚ Select object or objects
- ✚ Press enter(↵) on the keyboard
- ✚ Specify the base point
- ✚ Type scale factor (Greater than 1 to enlarge and less than 1 to shrink proportionally)
- ✚ Press enter(↵) on the keyboard

10. Stretch (s)

- ✚ Select object or objects (select only by crossing window)
- ✚ Press enter(↵) on the keyboard
- ✚ Specify the base point
- ✚ Type distance (the distance of the base point movement)
- ✚ Press enter(↵) on the keyboard

11. Fillet (f)

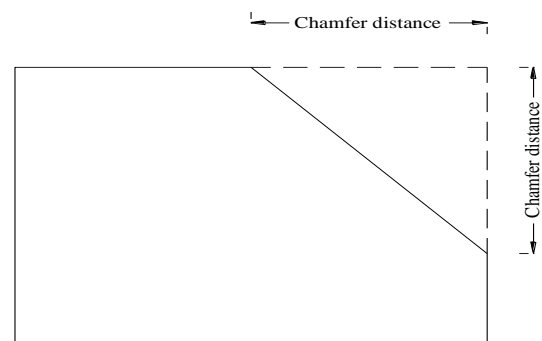
- ✚ Type r (to input radius first)
- ✚ Press enter(↵) on the keyboard
- ✚ Input radius
- ✚ Press enter(↵) on the keyboard
- ✚ Select the first object (line)
- ✚ Select the second object (line)



Special Notes: Use Fillet + “Shift” key to get sharp corner.

12. Chamfer (cha)

- ✚ Type d (to input distance first)
- ✚ Press enter(↵) on the keyboard
- ✚ Input first chamfer distance
- ✚ Press enter(↵) on the keyboard
- ✚ Input second chamfer distance
- ✚ Press enter(↵) on the keyboard
- ✚ Select the first object (line)
- ✚ Select the second object (line)



13. Explode (x)

- ✚ Select object
- ✚ Press enter(↵) on the keyboard

Figure 2.20: Chamfering

14. Match properties (ma)

- ✚ Select source object
- ✚ Select destination object or objects

Grips: Important Modification Tool

✚ Grips are those dots appear at the endpoint and midpoint of a line after selection.



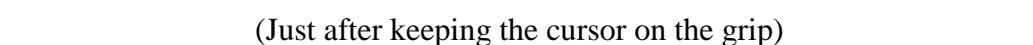
Unselected Grip (Blue)	
	(Just after selection)
Hover Grip (Green)	
	(Just after keeping the cursor on the grip)
Selected /Hot Grip (Red)	
	(Just after clicking on the grip)




Table 3: Table for various command

Action	Command appears	Result
Click on any end point	Stretch	Activate Stretch command
Click on the midpoint	Move	Activate Move command
Press “Ctrl” + click on the midpoint (Hold “Ctrl” until make one copy)	Copy	Activate Copy command







Click on any point then press “Enter”	-	Change from Stretch to Move, Rotate, Scale and Mirror
Press “Shift” + click on any point	-	Allow to select multiple grips

Format Tab












1. Unit

-  Choose appropriate unit system as drawing unit
-  Choose proper precision
-  Choose insertion scale (Unit of any value inserted without unit (i.e. ft/inch/mm etc.))




2. Text Style

-  Press “New”
-  Define style name
-  Specify font name (i.e. Times New Roman)
-  Choose a height
-  Press “Apply”
-  Press “Close”

3. Dimension Style

-  Press “New”
-  Define new style name
-  Press “continue”
-  Press “ Symbol and arrows” tab
 - ✓ Select first and second arrow head
-  Press “ Text” tab
 - ✓ Choose text style
-  Press “ Fit” tab
 - ✓ Set use overall scale of (Large value enlarges dimension text)
-  Press “ Primary Unit” tab
 - ✓ Choose unit format (Generally same as Drawing Unit)
 - ✓ Choose proper precisions (Generally same as Drawing Unit)
 - ✓ Zero suppression (Don’t show 0’ or 0” etc)
 - ✓ Suffix (if necessary to show something as suffix of the dimension text)
 - ✓ Prefix (if necessary to show something as prefix of the dimension text)
 - ✓ Scale factor (if necessary to multiply dimensions with any value)
-  Press “ ok”
-  Select dimension style created
-  Press “Set Current”
-  Press “Close”

4. Layer

-  Press “New layer”
-  Double click and rename “Layer Name”
-  Click and choose color

- ✚ Click and choose line weight
- ✚ Click on line type
 - ✓ If new line type is needed press “Load”
 - ✓ Choose a line type
 - ✓ Press “ok”
 - ✓ Select the loaded line type and press “ok”
- ✚ Repeat steps to create more layers
- ✚ Press “ok”

Special Notes:

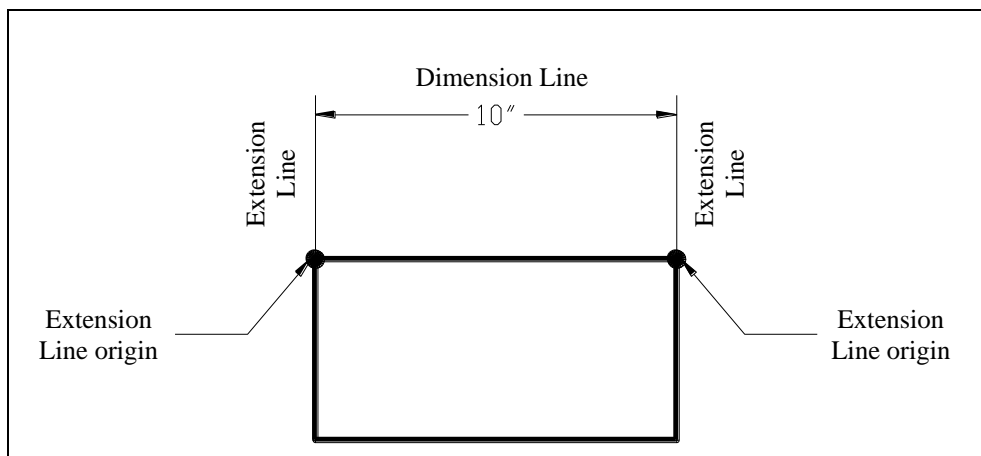
- New objects are drawn automatically with current layer.
- One can change objects layer manually from layer toolbar.
- When a layer is on, it is visible and available for plotting. When a layer is off, it is invisible and not plotted, even if Plot is on.
- If plotting is off for a layer, the objects on that layer are still displayed but will not be plotted.
- Objects on a locked layer cannot be modified.
- Objects on frozen layers are not displayed, plotted or regenerated.
- If dashed lines are not visible then change line type scale
 - ✓ Type “ Itscale ”
 - ✓ Press enter(↵) on the keyboard
 - ✓ Input scale factor (larger value make the gap visible)

Dimension Toolbar



1. Linear

- ✚ Click at the first extension line origin
- ✚ Click at the second extension line origin
- ✚ Click to fix dimension line location



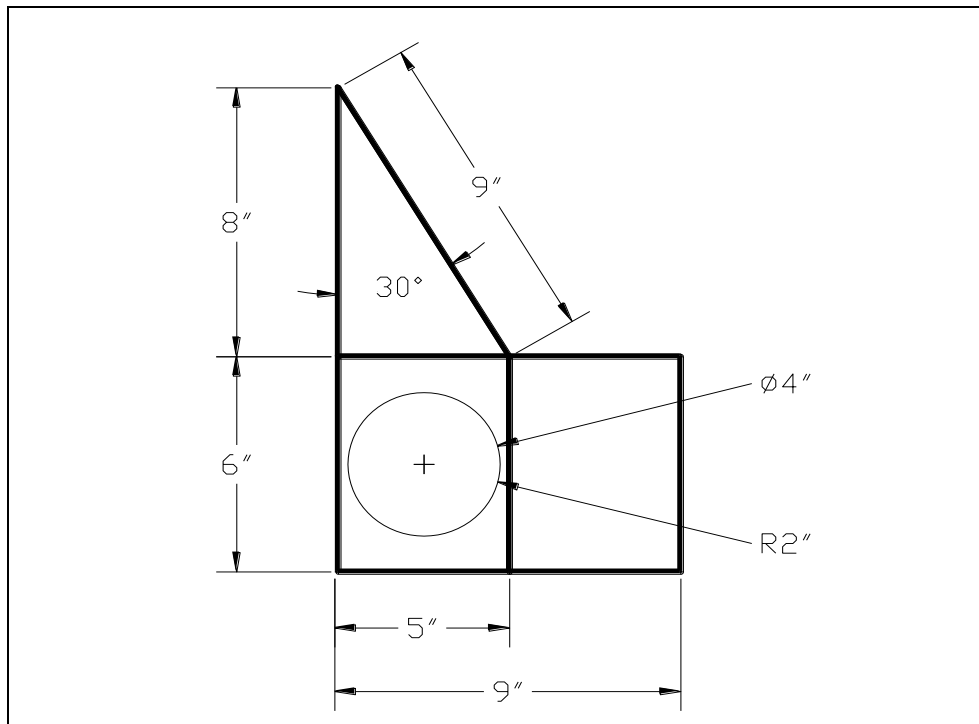


Figure 2.21: Linear Dimension

2. **Aligned**

- ✚ Click at first extension line origin
- ✚ Click at second extension line origin
- ✚ Click to fix dimension line location

3. **Continue**

- ✚ Continue from last dimension
 - ✓ Click at only second extension line origin and so on

Or

- ✚ Continue from any dimension
 - ✓ Types (to select a dimension)
 - ✓ Press enter(↵) on the keyboard
 - ✓ Select desired dimension
 - ✓ Click at only second extension line origin and so on

4. **Angle**

- ✚ Select the first line
- ✚ Select the second line
- ✚ Click to fix dimension line (arc) location

5. Radius

- Select circle
- Click to fix dimension line (leader) location

6. Diameter

- Select circle
- Click to fix dimension line (leader) location

7. Quick Leader

- Click at first leader point
- Click at next point of leader
- Click at next point of leader (if necessary)
- Input text width (default is ok)
- Press enter(↵) on the keyboard
- Type first line of annotation text
- Press enter(↵) on the keyboard
- Type second line of annotation text (if necessary, otherwise skip)
- Press enter(↵) on the keyboard

8. Dimension Text Edit

- Select dimension
- Click at desired location to set dimension text

9. Dimension Edit

- Press “New”
- Select and delete “0”
- Type desired dimension with unit or text
- Press “ok”
- Select dimension to be changed
- Press enter(↵) on the keyboard

Or

- Type “ddedit”
- Press enter(↵) on the keyboard
- Select existing dimension and delete
- Type desired dimension with unit or text
- Press “ok”

Miscellaneous commands

1. Polyline (pl)

- Specify first point (click at any point)
- Specify next point (click at any point)

or

- Specify first point (click at any point).
- Input length (type length of the line)

- ✚ Press “Tab” on the keyboard
- ✚ Input angle (type angle with the X axis)
- ✚ Press enter(↵) on the keyboard

Special note

- You can draw arc, line with certain width using polyline. For this just look at the command line.

2. Multiline (ml)

- ✚ Press “s” to input parallel line distance
- ✚ Press enter(↵) on the keyboard
- ✚ Press “j” to select zero (centerline)/top/bottom length
- ✚ Press “z” or “t” or “b”
- ✚ Press enter(↵) on the keyboard
- ✚ Specify first point (click at any point)
- ✚ Input length (type length of the line)

3. Divide (div) [Draw > Point > Divide]

- ✚ Select object to divide
- ✚ Input number of segments
- ✚ Press enter(↵) on the keyboard

Special notes:

- To see the points on the line, create point style
- Format > Point style > Choose point icon > ok

4. Measure (me) [Draw > Point > Measure]

- ✚ Select object to measure
- ✚ Input length of segments
- ✚ Press enter(↵) on the keyboard

Special notes:

- To see the points on the line create point style
- Format > Point style > Choose point icon > ok
- If total length is not a multiple of the length of segments then AutoCAD measures segments from the left side. Right most segment will be the remainder.

5. Align (al)

- ✚ Select objects
- ✚ Press enter(↵) on the keyboard
- ✚ Specify first source point
- ✚ Specify first destination point
- ✚ Specify second source point
- ✚ Specify second destination point
- ✚ Press enter(↵) on the keyboard

- ✚ Scale objects based on alignment points?
 - ✓ Yes (distribute and scale objects within the destination points)
 - ✓ No (only align objects without scaling)

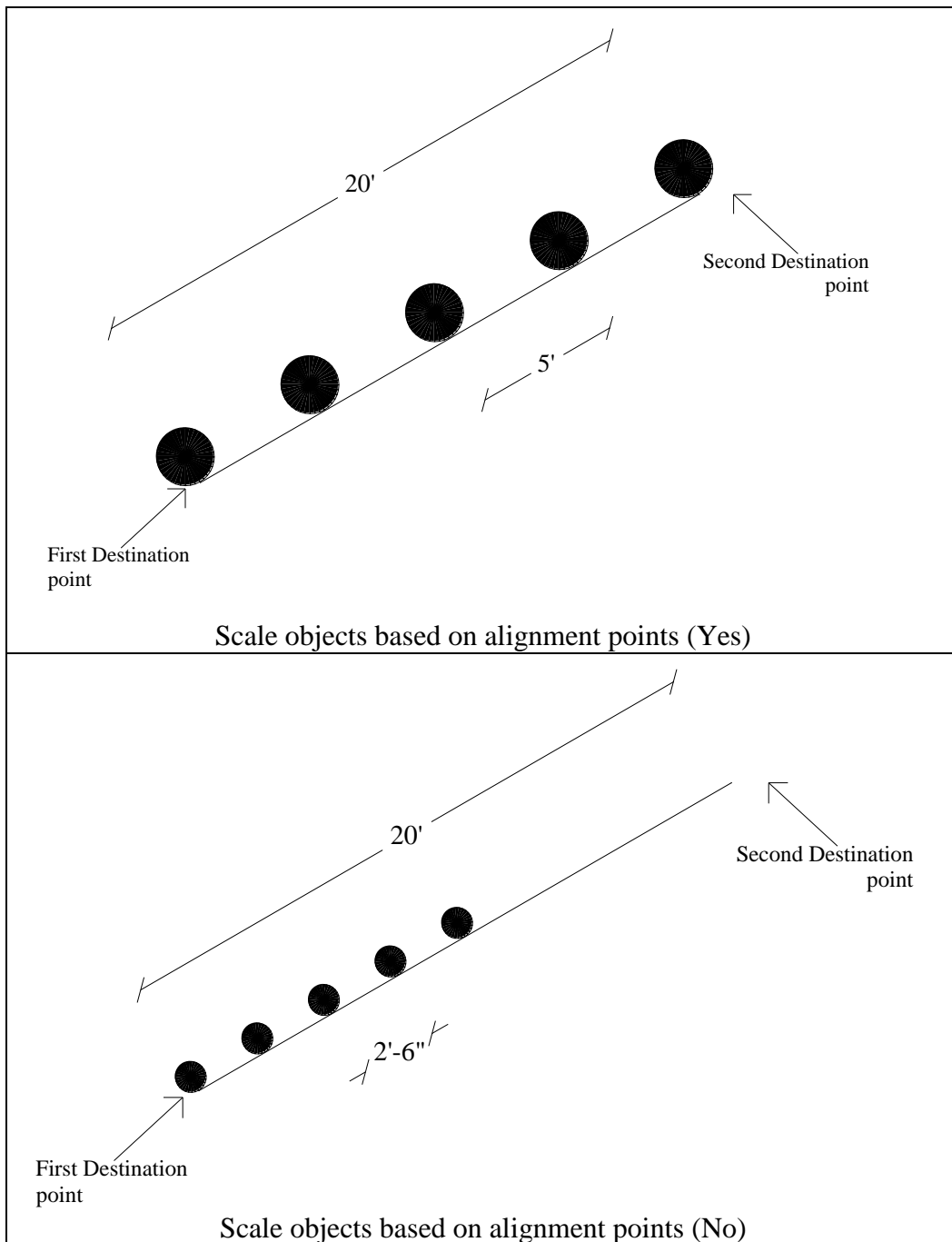


Figure 2.22: Dimensioning Along Align Plane

6. Group (g)

- a. Create group
 - ✚ Type group name

- ✚ Press “New”
 - ✚ Select desired objects
 - ✚ Press enter(↵) on the keyboard
 - ✚ Check “selectable”
 - ✚ Press ok
- b. Modify group
- ✚ Select group name
 - ✚ Pick desired edit option (remove or add objects or explode)
 - ✚ Select desired objects
 - ✚ Press enter(↵) on the keyboard
 - ✚ Press ok

6. Oops (oops)

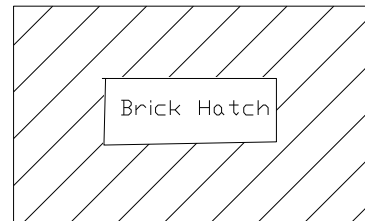
- ✚ Type “oops” in command bar
- ✚ Press enter(↵) on the keyboard

Special Notes:

- This command restores the last deleted item only even you use other command in between.
- Different from undo option because it (undo) only cancel last command.

7. Wipeout (wipeout)

- ✚ Type “wipeout” in the command bar
- ✚ Draw any shape to clean hatch pattern
- ✚ Press enter(↵) on the keyboard



Important Control Keys

Control Keys	Result
CTRL+8	Launches calculator window
CTRL+A	Select all
CTRL+N	Create new drawing
CTRL+P	Opens the plot dialogue box
CTRL+S	Opens the save dialogue box
CTRL+Z	Undo the last operation
CTRL+TAB	Switches between open drawings
Esc	Cancel command

Object Properties

Every AutoCAD, such as or a line or a circle has properties. Some properties such as color, Line type and Layer are common to all objects. Some object have properties which are specific to themselves. Text, for example, is the only object type which has a style property. In AutoCAD Release 14, the easiest way to control object properties is to use the object Properties toolbar, illustrated below. This is one of AUTOCAD,s default toolbars and can

usually be found directly below the standard toolbar in the top left hand corner of the AUTOCAD window.



Take time to work through this tutorial, it is particularly important to get to grips with object properties since it can make the difference between a really good AUTOCAD drawing and a really terrible one. If you just need information quickly, use the Quick Find toolbar below to go straight to the information you need or select a topic from the contents list above.

Layers

Probably the most important object property to understand well is the layer property. Experienced AutoCAD users use layer all the time and that is why the object properties toolbar contains so many layer function. Good use of layer is the most important aspect of good drawing practice.

The concept of layer is very important in AUTOCAD and the correct use of layer can make your drawing much easier to work with. Basically, layers are the computer equivalent to tracing overlays on a drawing board. However, layers are much more powerful because you can have many layers in a single drawing and you can control the visibility, color and line type of layers independently. This makes working with very complicated drawings much more efficient. Layers are effectively a way of ordering your drawing. For example, you may need to create a number of construction lines in a drawing which will not form a part of the finished image. You could create a layer called “Construction” and use this for your construction lines. When the drawing is completed, you could simply turn this layer off so that it can’t be seen. The beauty is that you can could always turn this layer back on at some future time if modifications to the drawing are required. Experienced AUTOCAD users will use layers to order their drawing by drawing components. For example, if you were creating landscape master plan, you may have layers called “Trees” “Shrubs” “Path” etc. The main reason for this, apart from it being a simple way to control the drawing, is that the different drawing components may need to be printed in different colors with different line type and with different line widths. Layers can be used to control the way objected are displayed on the computer monitor and how they appear when they are printed.

It is a common misapprehension amongst new users that layer can be used to control the visual hierarchy of objects. In other words, if two object overlap, it seems reasonable to assume that you could cause one object to display “above” another with the model is common to illustration software such as core IDRAW. However, AutoCAD uses a 3 dimensional drawing space where all object coexist and are position in their correct co-ordinate locations. The concept of an object being displayed above or below another, therefore, is not consistent with this logic. In AUTOCAD the displayed of one object in relation to another is determined by the objects place in the drawing database. objects draw more recently will display over another if the two objects occupy the same physical space.it is possible to override this effected Display order tools found on the Tools pull-down, Tolls

Display order option these option are particularly useful to control the display of overlapping solids and solid hatches that are coplanar. The layer of an object has no its display order,

Although you can have many layers in a drawing, you can only draw on one layer at a time. The layer you are drawing on is said to be the current layer. The object properties toolbar displays the current layer information. In the illustration above, you can see that layer “0” is the current layer and that the color and line type are set ‘By layer’

When you start a new drawing, AUTOCAD has only one layer. This layer is special and is called layer ‘0’ (zero).layer 0 is special because you cannot change its name or delete it and is has certain properties which we do not need to consider just now. By default layer 0 is assigned the color white (color number 7) and this “Continues” line type. Layer 0 is always the current layer when start a new drawing, however, it is bad drawing practice to use layer 0 for normal drawing. The first thing you should do therefore, when you start a new AUTOCAD is to create some new layers.

The layer command

LAYER (manages or LAYER and layer properties)


Command line: Type LA or LAYER(layer) and press enter.

Format menu: layer.....

Layers toolbar: pick Layer Properties Manager tool

Although AUTOCAD provides many shortcuts for working with layer, many of which will be covered later, the layer command provides the most comprehensive control over layers and layer operations. This command uses a dialogue box. The dialogue box is a tabbed dialogue box and can be modified to show more or less details. This is quite nice because in its simplified form it looks much less intimidation to beginners. The following sections demonstrate how the layer command can used to perform many of the most layer operations.

Creating a New Layer

To create a new layer, click on  in the layer toolbar, the Layer properties Manager dialogue box, illustrated below, appears. This is a tabbed dialogue box and can be used to control either layer properties depending upon which tab is selected. The layer tab is always selected by default. Now click on the ‘New’ button. A new layer called ‘layer’ is automatically created in the layer list below layer 0. As you can see from the illustration the layer name is automatically highlighted for you so that you can give the layer a more meaningful name. When you have entered an appropriate name, press key to complete the operation. You have now created a new layer and given it a name. Notice that by default it has been assigned the color white and the line type ‘Continues ‘.

There are a few restriction to consider when you are naming layers. The most annoying is that you cannot use spaces within layer names. So, for example, the layer name “ Tree trunk” is illegal, However, it is common practice to replace the space with either a hyphen or an underscore, both of which are valid layer name character. So, the layer name “Tree trunk” and “Tree trunk” are both acceptable. Some other special characters are also not allowed. If

you do use an illegal character, Auto CAD will alert you with the error message box illustrated above. Notice that it very helpfully tells you which characters are legal. Basically, if you stick with letters and numbers you won't experience any problems. In addition to the hyphen and underscore mentioned above, the dollar sign is the only other symbol allowed.

The only other restriction relating to layer names is the number of characters used. Layer names can be between one and thirty-one character long. This should give you plenty of scope to devise understandable and descriptive names for your layers. It is good drawing practice to name your layer sensibly, bear in mind that other people may have to work with drawing which you creator. If you enter a layer name longer than 31 characters, Auto CAD will display the error message box.

Layers are always listed alphabetically in layer lists, the user has no way to control the list order. It is worth bearing this in mind when naming your layers. Keep similar object layers together by devising a hierarchical naming structure. For example, if you are drawing a tree symbol which comprises a number of elements, your layer names might be, "Tree canopy" "Tree text" "Tree trunk" etc. This will cause all the Tree layer to be displayed together, see the illustration on the left. This is quite important because in complicated drawing there may be many layers and searching for the right group of layers can waste a lot of time.

Setting Color and Line type "ByLayer"

Auto CAD two methods of setting the color and Line type of a drawing object. First of all, color and Line type can be set ByLayer. In other words, an object will be displayed in their color and Line type of its layer. For example, if you draw a circle on a layer which you have called "Details" and you have also set the color of Details to blue and the Line type to dashed, then the circle will be displayed in a dashed blue line. When an object takes on the properties of its layer, the color and Line type are said to be set "ByLayer".

The second method AutoCAD offers is to set the color and Line type by object. Setting properties by object overrides those set ByLayer. In general it is drawing practice to set color and Line type properties ByLayer, this is more efficient and less confusing in the long-run. For example, imagine that you have drawn hundreds of objects on the same layer and have set their color to green. Later in the drawing process you decide that these objects should, in fact, be yellow. In order to make the change you would have to use the Properties command and select every one of the objects by picking them. By contrast, if you had set the objects color ByLayer, you would only have to change the layer color from green to yellow and all of the objects would change.

Setting the Color of Layer

It is often convenient to set the layer color when the layer is created. Although this can be done at any time. The layer color can be changed as many times as you like. Each time it is changed, any objects on that layer will change to the new color, providing their color is set to "ByLayer"

To set a layer color, open the Layer Properties Manager dialogue box, click on and then click on the color icon in the layer list associate with the layer you want. Notice that all layers have their own color icon and that this changes to display the layer color. Clicking on the icon brings up Select Color dialogue box, shown on the right. You can select nay of the 255 standard AutoCAD colors by picking on the color palette or by entering the color name or number in the text edit box. When you have selected the color you want, click on th “OK” button to set the color. AutoCAD uses only 255 color plus the drawing background color, irrespective of the capability you video display.

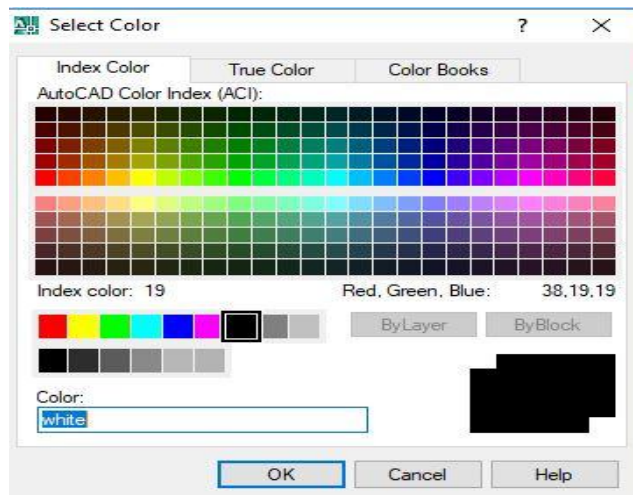



Figure 2.23: Selecting Line Color

Assigning different colors to your layers will make working with complex drawings much easier. You will be able to see at a glance what a particular line represents. For example, your construction lines may be on a layer called “Construction” and have the color yellow. This will visually differentiate these lines from lines on other layers with different colors.

Setting the Line type of a Layer

In the same way that you can assign a color to a layer you can also assign a Line type to a layer. For example, you could have all the lines. To set a Line type to layer, click on  and then click on the current Line type name associated with your layer in the layer list. By default, layer have the “Continuous” Line type. Clicking on the line type name brings up the Select Line type dialogue box, shown on the bottom. You will notice that the “Continue” Line type is the only one listed. That’s because all Line types, except “Continue” are stored in an external file and have to be loaded before they can be used.

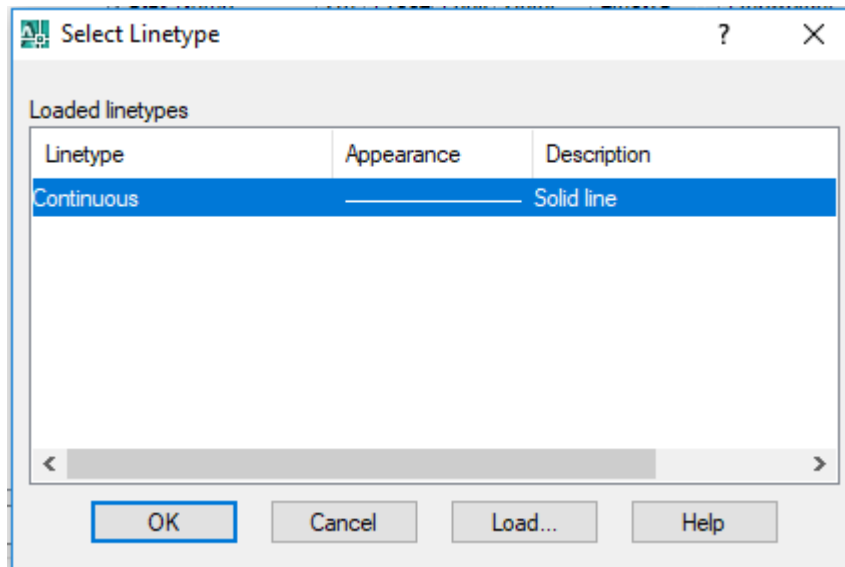


Figure 2.24: Selecting Line Type

Loading Line type

To load a Line type, click on the “Load...” button in the Select Linetype dialogue box. The Load or Reload Line type dialogue box appears and display list of the available Line types. Select as many of the listed Line types as you wish and then click the OK button to return to the Select Linetype dialogue box.

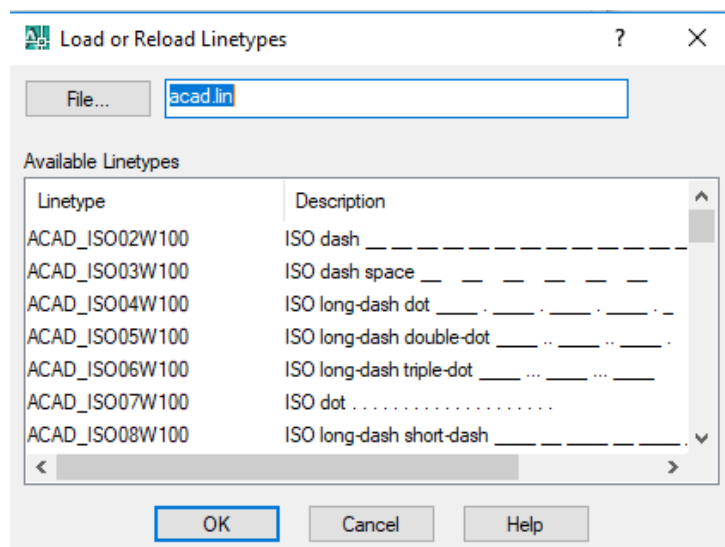



Figure 2.25: Loading Line Type

Selecting from list boxes works the same way in AutoCAD as it does in any other Windows application. For example, if you wish to select a block Line types from the list at one time, select the first Line type in the block, hold the shift key down on the keyboard and select the last Line type in the block. All Line types in the block will be highlighted and you can click the “OK” button to load them all one go. You can hold the Control (Ctrl) key down on the keyboard to make multiple selections which aren’t adjacent in the list (see illustration above).

When you return to the Select Line type dialogue box the loaded Line types are display in the list. To assign a particular Line type to a layer, simply click on the name to highlight it and then click on the OK button, when you return to the Layer & Line type Properties dialogue box, the new Line type name will be listed against your layer in the “Line type” column. From now on, all object drawn on this layer will be drawn with the chosen Line type. However just like colors, you may change the Line type at any time and the objects drawn on that layer will automatically be updated to display the new Line type.

Changing Line weight of a Layer

Command line: Type LA (layer) and press Enter (↵)

Format menu:  Layer.....

Layers toolbar: pick Layer Properties Manager tool

Procedure:

Step1: Input Layer command (any one of above way) [A Layer Properties Manager box will appear]

Step 2: Select a Layer

Step 3: In the Line weight column, click box on the line weight size of the layer to change (Line weight box will appear)

Step4: Select any Line weight you want and click on Ok button (Line weight box will disappear)

Step 5: Click on OK button again to terminate the command

Making a Layer the Current Layer

Once you have created some layers you will want to start using them. As indicated above, you can only draw on one layer at an item. In order to draw on a particulars layer you must first make it the current layer. As usual with AutoCAD there are a number of alternatives. You could, for example, use the Layer command, Layer... from the Format menu of from the Layers toolbar. As you have seen previously, this command brings up the Layer Properties Manager dialogue box. To set the current layer, select a layer name from the list and then click on the “Current” button and then click the “OK” button to finish. The selected layer is now the current layer and its properties are displayed on the Layer toolbar.

Most experienced Auto CAD users change the current so frequently that the method starts to seem very long winded. It is much quicker and therefore more efficient to set the current layer directly from the layers toolbar using the “Layer Control” drop down list. To set the current layer, click on the down arrow next to the layer control window to reveal the layer list. Simply click on the name of the layer you wish to make current. If the layer name is not visible because the list is quite long, Scroll down the list until you see it. The drop down list only display 10 layer at a time. As a beginner, you may feel that this is quite a lot but a complex and well structured drawing may have 50 or 100 layers.

There is an even quicker way to change the current layer providing you know which layer objects are on. You can use the Make Object's Layer Current command to set the current to the layer of any picked object.

Option 1:

Command Line: Type **LA** (layer) and press **Enter**.

Format menu: Layer

Layers Toolbar: pick **Layer Properties Manager** tool.

Procedure:

Step 1: Input Layer command (any of the above way)

Step 2: Select a layer and click on **Current** button.

Step 3: Click on **OK** button to terminate the command.

Option 2:

Procedure:

Step 1: Select any object of the layer you want to make current (with-out any command)

Step 2: Click on the **Make Object's layer Current** tool from the **Layers** toolbar.

Option 3:

Procedure:

Step 1: From the **Layers** toolbar, open the layer control drop down menu.



Step 2: Click on the layer's name you want to make it current.

Sending Object from One Layer to Other Layer

Procedure:

Step 1: select any object you want to transfer to other layer.

Step 2: From the **Layers** toolbar, open the layer control drop down menu.



Step 3: Click on the layer's name where you want to transfer.

Step 4: Press **Esc** button.

Freezing and Thawing Layers

Freezing and thawing layers works in exactly the same way as turning them on or off. By freezing a layer, you can effectively instruct the AutoCAD to ignore the objects on that layer when regenerating the drawing. Objects on freezing layers are not displayed or plotted.

Locking and Unlocking Layers

Locking and unlocking layers work as for turning layers off and on and freezing and thawing them. Simply click on lock button to toggle an unlocked layer so that it becomes locked and click on unlock button to reverse the process.

Deleting a Layer

To delete a layer, click the name of the layer to highlight it, click the “**Delete**” button and then click “**OK**”.

Setting the Line-type Scale

In many cases your line-types will display just as you want them. However, it is inevitable that at some time you will need to change the scale at which yours line-types are displayed. By default the line-type scale is set to 1.0, this means that each line-type pattern will repeat every 1.0 drawing units. To make the pattern appear larger, change the scale to a larger number. Setting the line-type scale to 5.0 for example causes the line type pattern to repeat every 5.0 drawing units so that the pattern will appear 5 times larger. Conversely, setting the scale to 0.2 drawing units which will make the pattern appear 5 times smaller. See the illustration below.

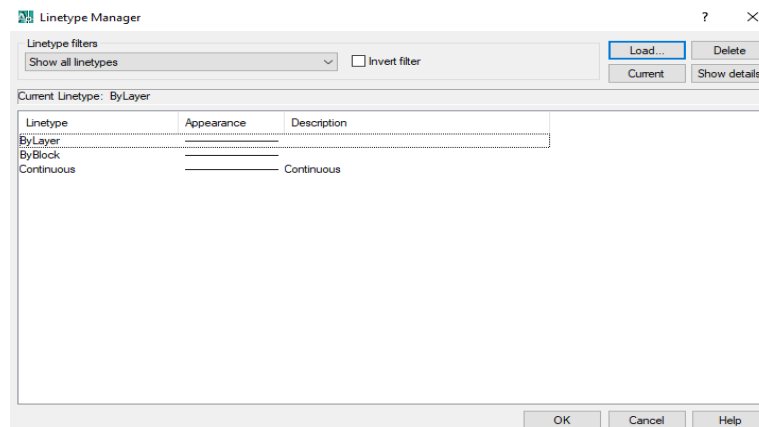


Figure 2.26: Selecting Line Type Scale

Changing Object Properties

There will be occasions when an object properties will need to be changed. Say, for example, you have drawn an object on the wrong layer. It’s much simpler to change the layer for that object rather than to erase the object, set the current layer and draw it again. There are a number of ways in which an objects properties can be changed but the most common method is to use the Properties command. Remember that you cannot change the properties of the objects on locked layers.








The Properties Command

Command Line: Type **PR** or **PROPERTIES** and press Enter.

Modify Menu: Properties

Standard Toolbar: Pick Properties tool.

The followings are eight general properties common to all objects:

-  Color
-  Layer
-  Linetype
-  Linetype scale
-  Plot style
-  Lineweight
-  Hyperlink

 Thickness

Editing with the Object Properties Toolbar

Although editing object properties using the Properties command is easy enough, AutoCAD introduces a new and more efficient way to modify the Layer, Color, and Line-type of an object. By using the Object Properties Toolbar, the layer, color, line-type of an object or objects can be modified directly, without the use of a command.

The Match Properties Command

Another way to change the properties of an object or object is to match the properties of any other object using the Match Properties command on the standard toolbar.

Command line: Type MATCHPROP (match properties) and press enter

Modify menu: Match Properties

Standard toolbar: pick Match Properties tool.

Command Sequence:

Command: MATCHPROP

Select a source object: (pick the object you wish to match)

Current active setting: Color Layer Ltscale Line weight THICKNESS PLOTSTYLE Text DIM HATCH POLYLINE VIEWPORT.

Select destination object(S) of [setting]: (pick the objects to inherit properties)

Select destination object(s) or [setting] (to terminate the command)

Once the command sequence has been completed, the destination object will inherit all of the current active setting which are specific to that object type. You can control which properties are matched and which are not by using the 'setting' command line option.

Changing

Line weight or layer

Command: menu type a layer and press Enter

Format menu: Layer

Layer toolbar: pick layer Properties Manager

Procedure:

Step 1: Input Layer command (any one of the above way) [A Layer Properties Manager box will appear]

Step 2: Select layer

Select 3: In the **Line weight** column, click on the line weight size of the layer to change (Line weight) box will appear)

Select 4: Select any Line weight you want and click on **OK** button (Line weight box will disappear)

Select 5: Click on OK button again to terminate the command.

Tips for Working Faster in AutoCAD

Working faster is not simply beneficial for finishing exams by deadlines, but also very important to employers for whom efficiency and production speed are critical to business success.

1. At first think about the drawing to indentify centerlines or a starting point.
2. Try to develop a preference for using commands at the keyboard rather than selecting icons in toolbars or items in menus. It is much faster.
3. Always look at the command line for guidance when you are learning new AutoCAD commands. The command line will prompt you for information and this is the easiest way to find out how a new command works.
4. When a command is used, apply it as many times as you can before going on to something else.
5. Press the “Enter” or “Space” button to activate last used command.
6. Press the up-arrow and down-arrow keys to cycle through the stack of commands that you’ve used recently.
7. Try to think ahead as you draw. This will enable you to do more things at the same time, and it will reduce down time needed for thinking before proceeding to the next task.
8. To trim overlapping lines at corners, use the Fillet command with a “0” radius. If the fillet radius is set to round corners, remember that you can hold down on the Shift key to use Fillet as though the radius were set at "0" even though it is not. You will save the time required to reset the radius.
9. Fillet two parallel lines to get an arc.
10. To extend or trim try to select all as destination line or cutting edge by using Right click of mouse. Use Shift key to alter extend and trim command.
11. Every command makes it faster to do something. Practice and remember such commands as Copy, Mirror, Stretch, and Array etc.
12. Often Copy and Paste objects rather than recreating them. Even objects as simple as circles are often copied more quickly than drawing each one individually.
13. Copy and Edit text, leader lines, and arrows rather than re-invoking the Text or Leader command and taking time to go through the basic options. Leader lines can very easily be adjusted by manipulating the grips.
14. If a line or other object is drawn incorrectly, think first of correcting it by manipulating its grips. It is usually much faster than deleting it and redrawing it correctly. Don’t go slow for fear of making mistakes.
15. Avoid switching back and forth between layers. Create everything on the layer that most objects will be on, and then at the end reassign objects to the correct layers. Reassign one object, and use Match Properties to reassign all other objects that should be on the same layer.
16. Compete with yourself to increase drawing speed and efficiency.

Courtesy: <http://www2.hawaii.edu/~dmadden/acad%20tips.htm>

Chapter 3

Plan, Elevation and Section of a Building

This chapter covers the application of AutoCAD as drawing tool of Civil engineering structures specially Building plans, elevations and sections. In this chapter plan of a masonry building has been presented first and elevation and section has been demonstrated based on that particular plan. This will enable student to understand practical use of AutoCad in Civil engineering.

Necessary Drawing Tools: Line, Rectangle, Arc, Circle, Hatch, Text etc.

Necessary Modifying Tools: Erase, Copy, Move, Mirror, Offset, Rotate, Trim, Extend, Fillet, Chamfer

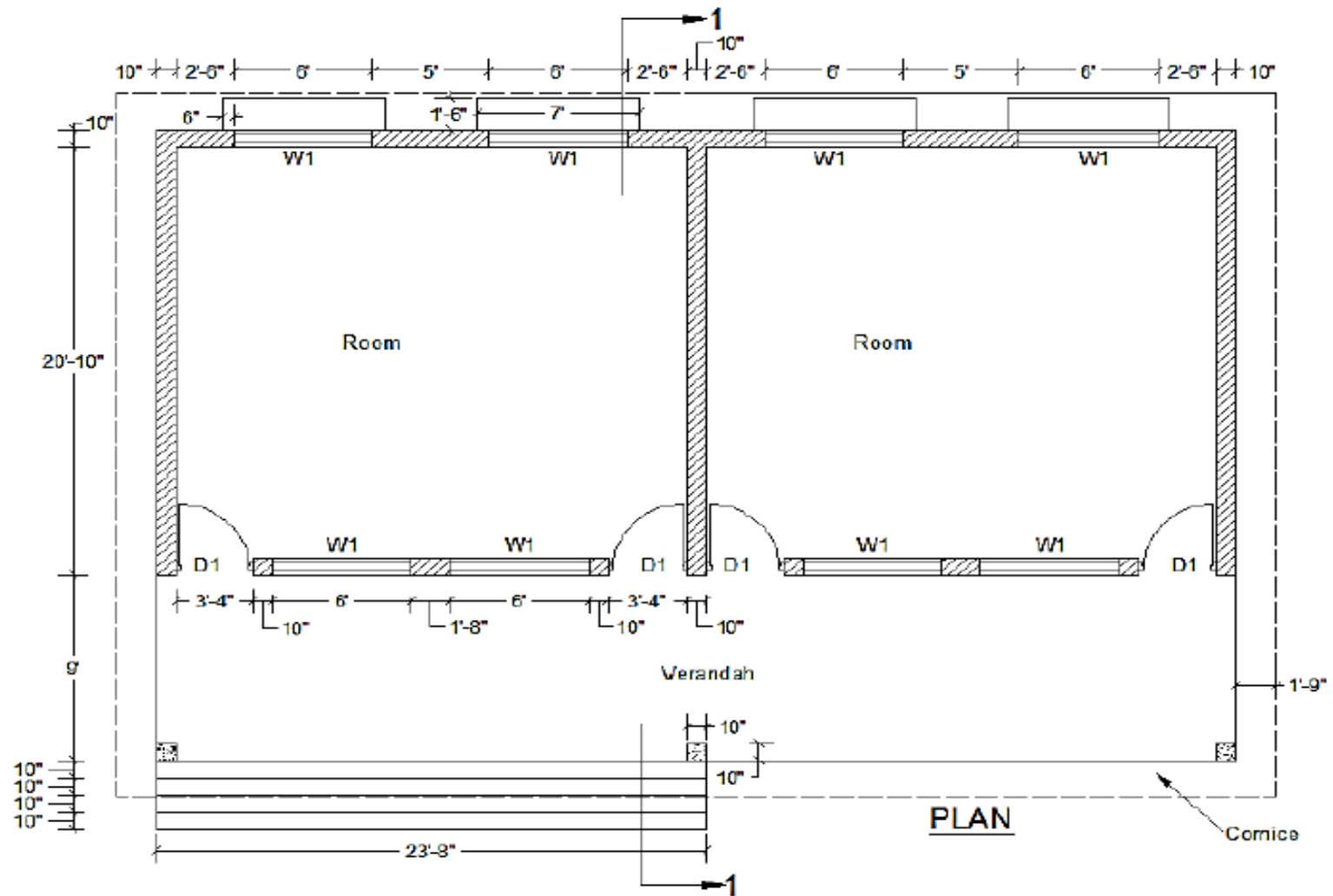


Figure 3.1: Plan of a residential building

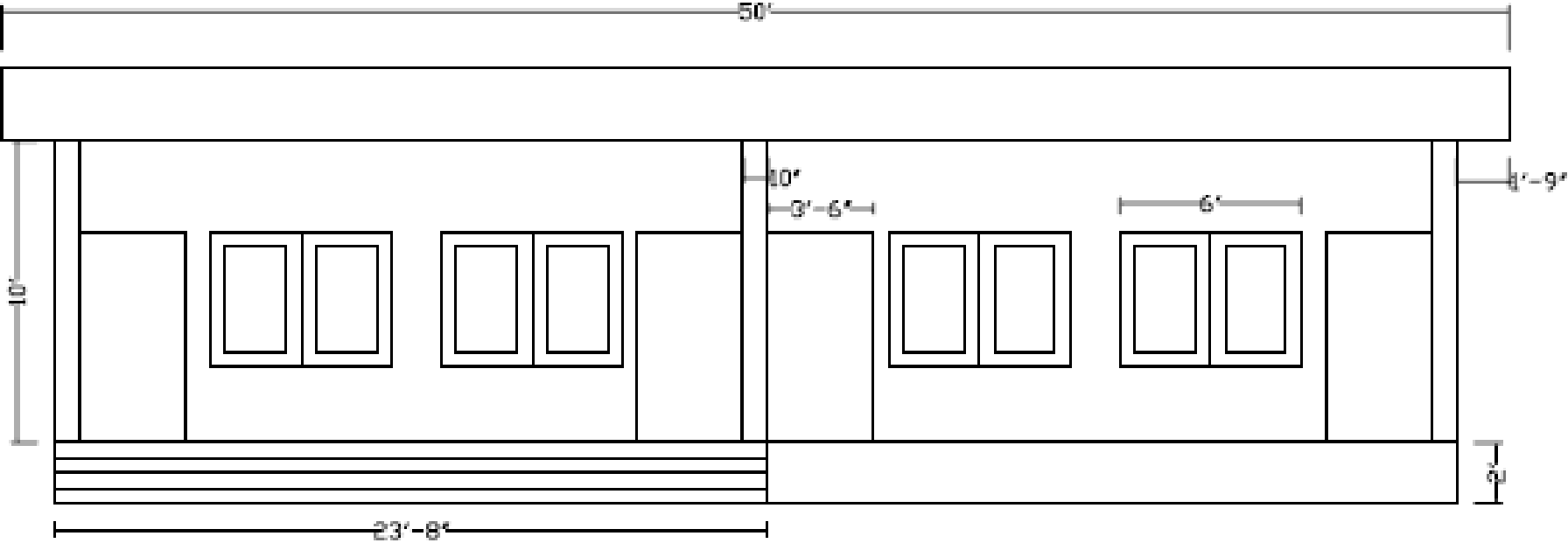


Figure 3.2: Front view of the building

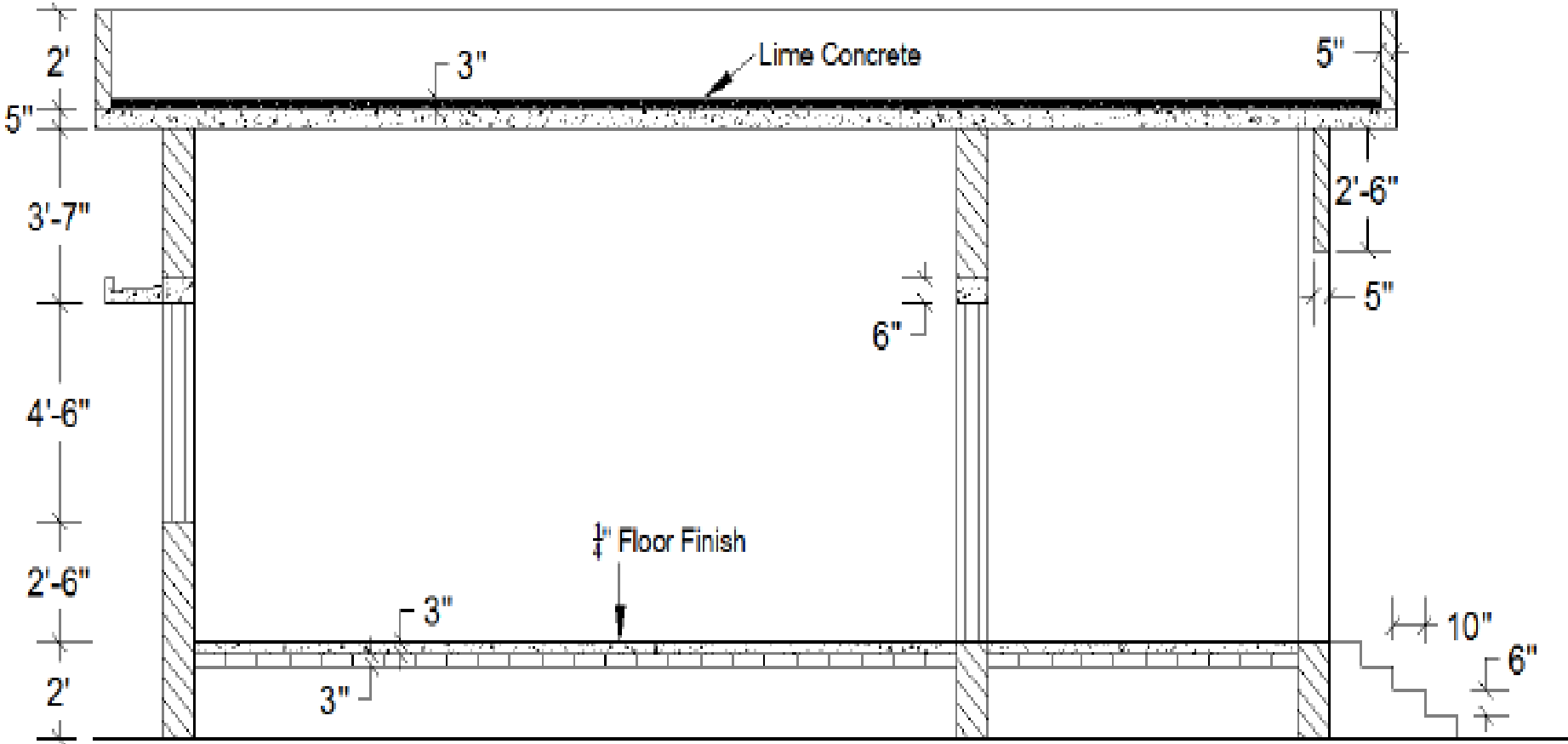


Figure 3.3: Section 1-1

Chapter 4

Reinforcement Detailing

This chapter covers the application of AutoCad as a drawing tool of Civil engineering structures specially foundation, reinforcement detailing of slab, beam and stair. This will enable student to understand practical use of AutoCad in Civil engineering.

Necessary Drawing Tools: Line, Rectangle, Arc, Circle, Hatch, Text etc.

Necessary Modifying Tools: Erase, Copy, Move, Mirror, Offset, Rotate, Trim, Extend, Fillet, Chamfer etc.

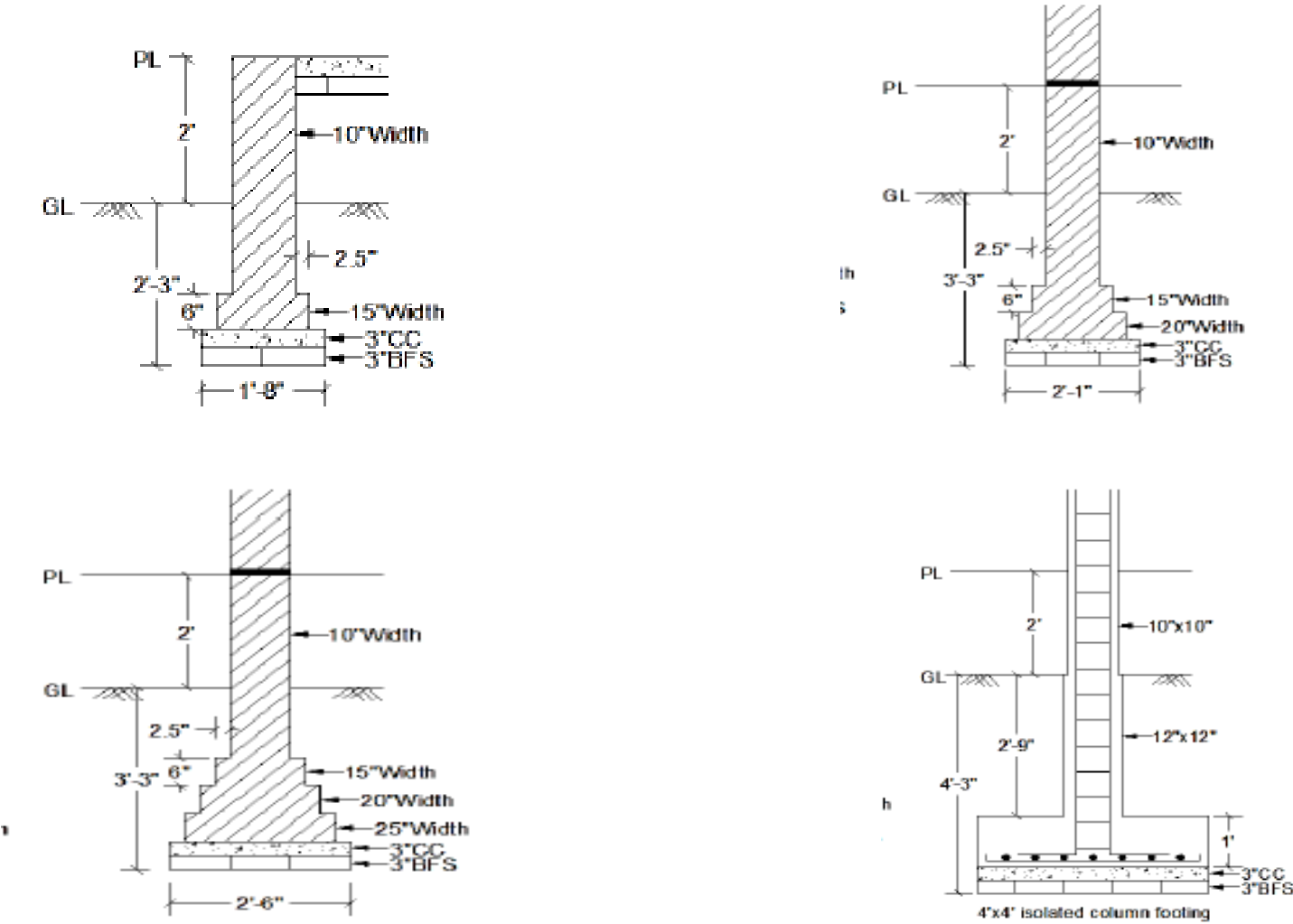


Figure 4.1: Wall Footing and Column Footing

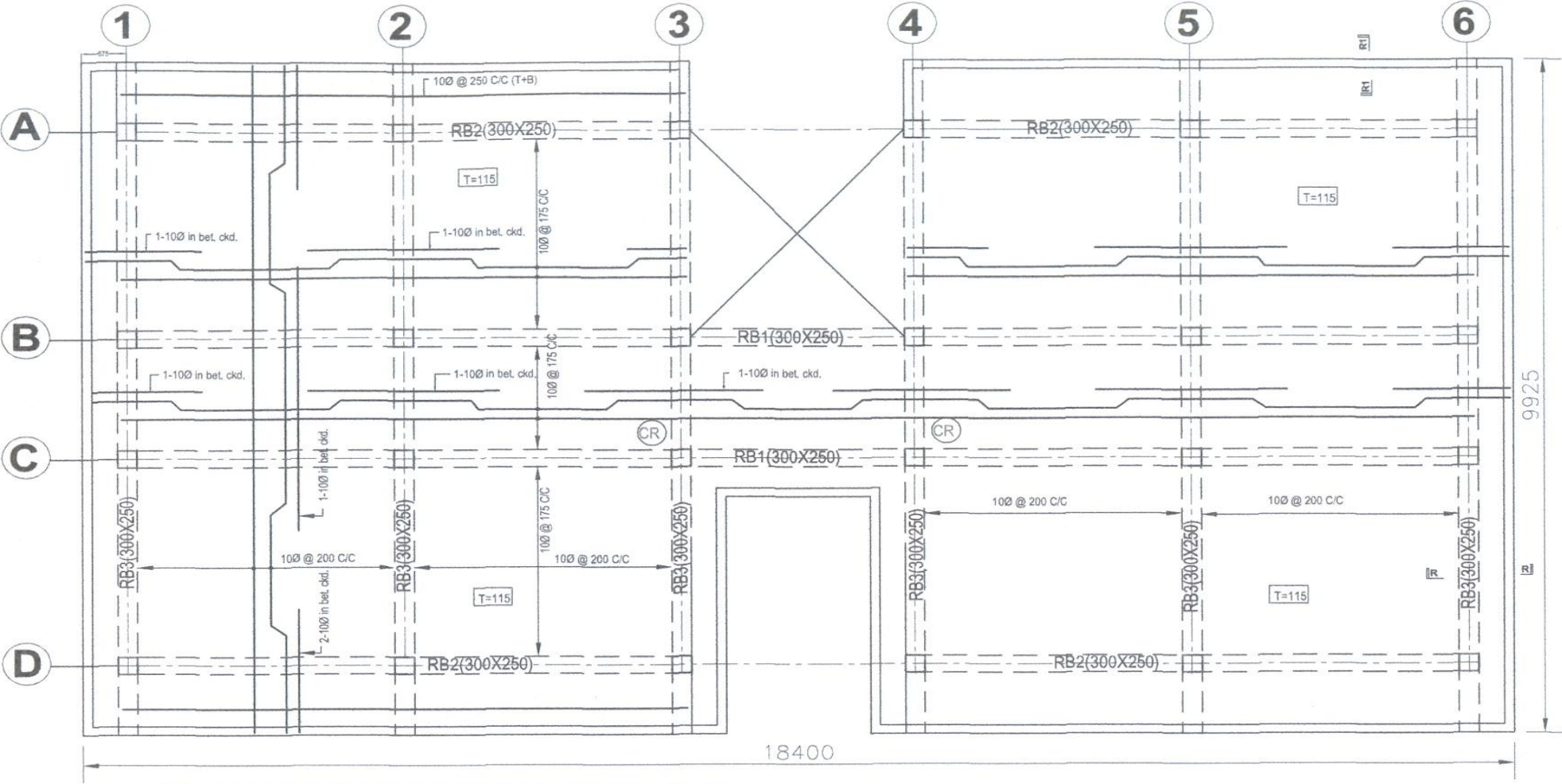


Figure 4.2: Reinforcement details of roof slab

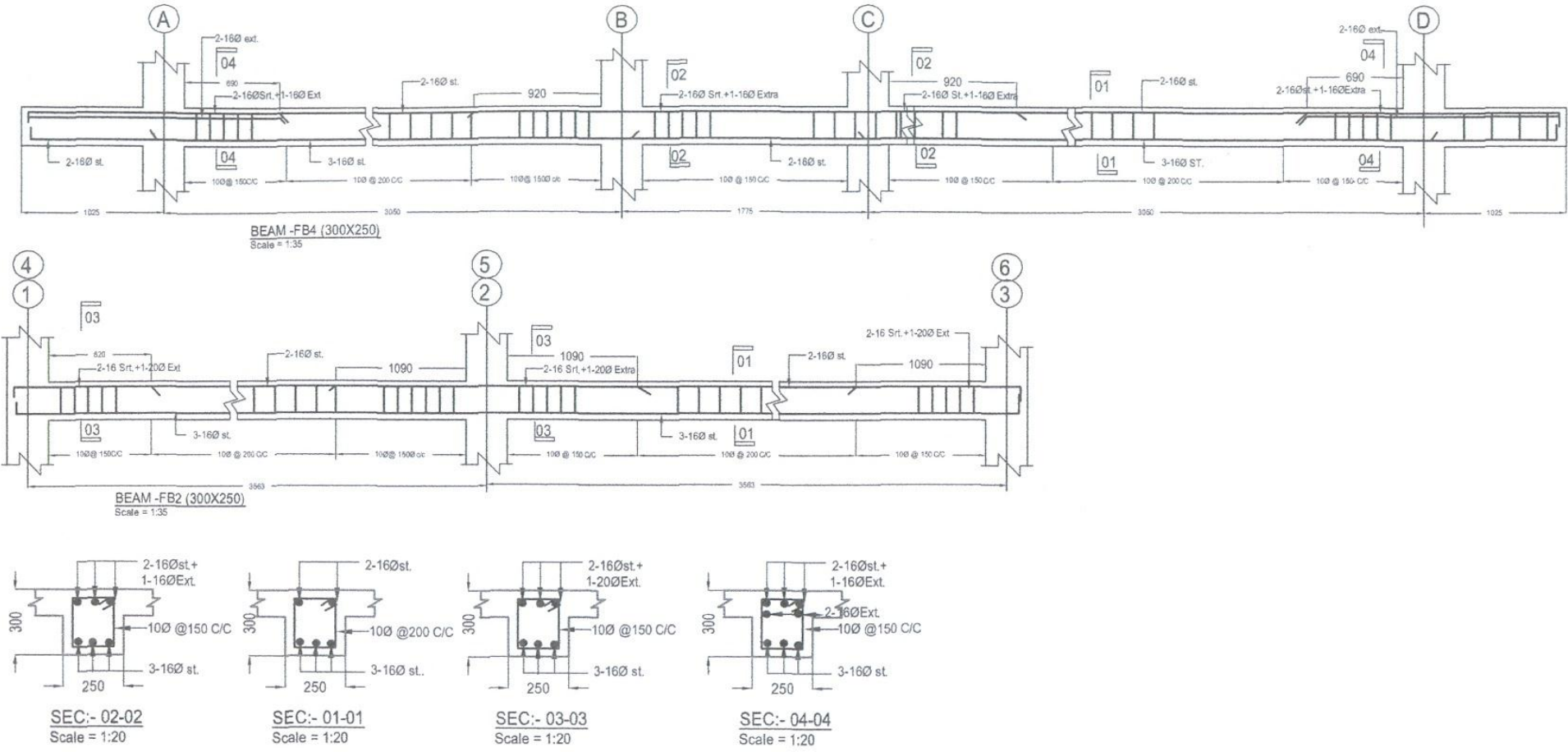


Figure 4.3: Longitudinal and Cross section of beam

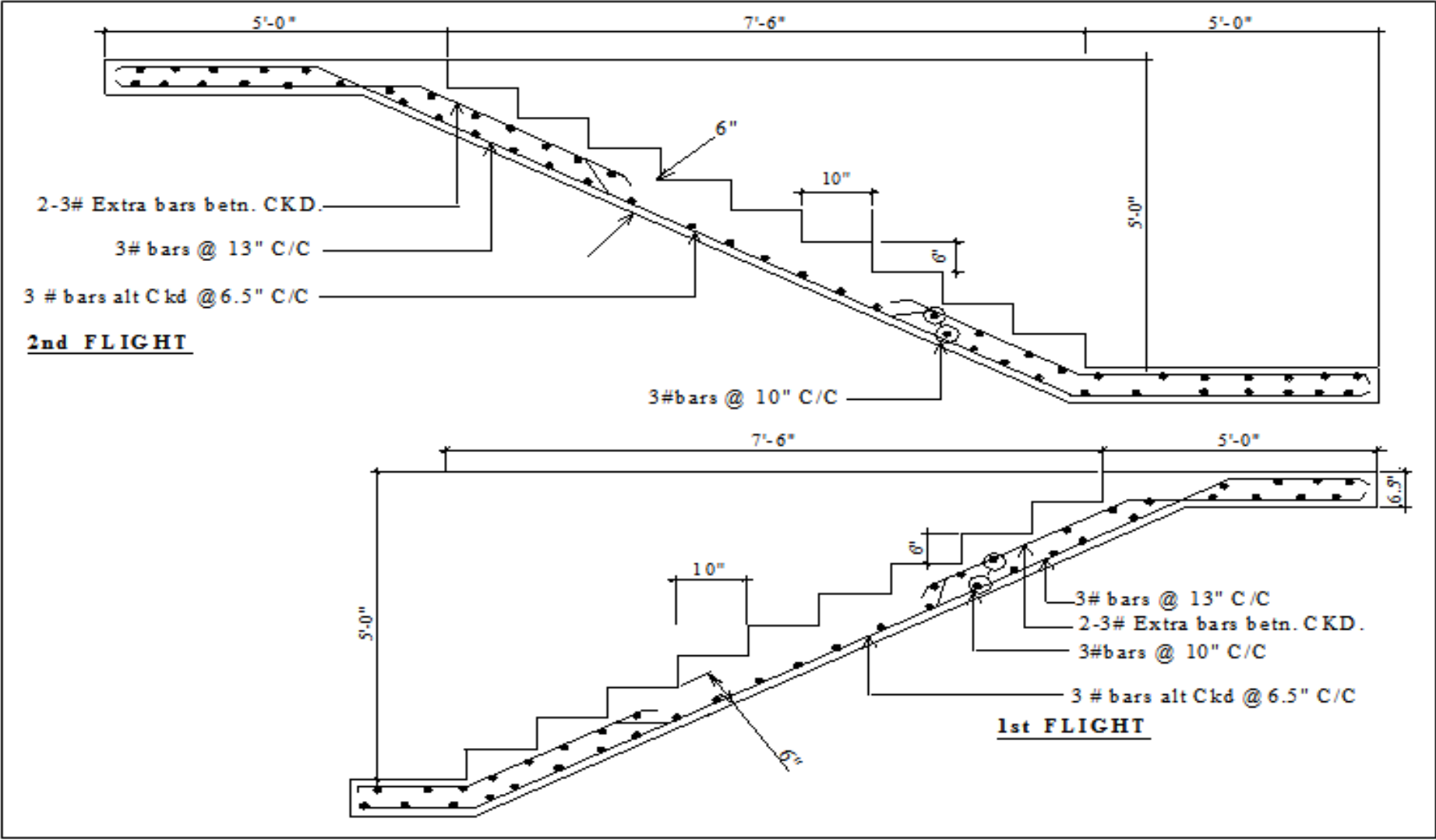


Figure 4.4: Reinforcement detailing of stair

Chapter 5

Plan, Section and Elevation of Slab Culvert

From this Chapter Students will able to learn about different types of Culvert and they will be able to draw the plan and Sectional Elevation View of Slab Culvert by using different tools of AutoCAD.

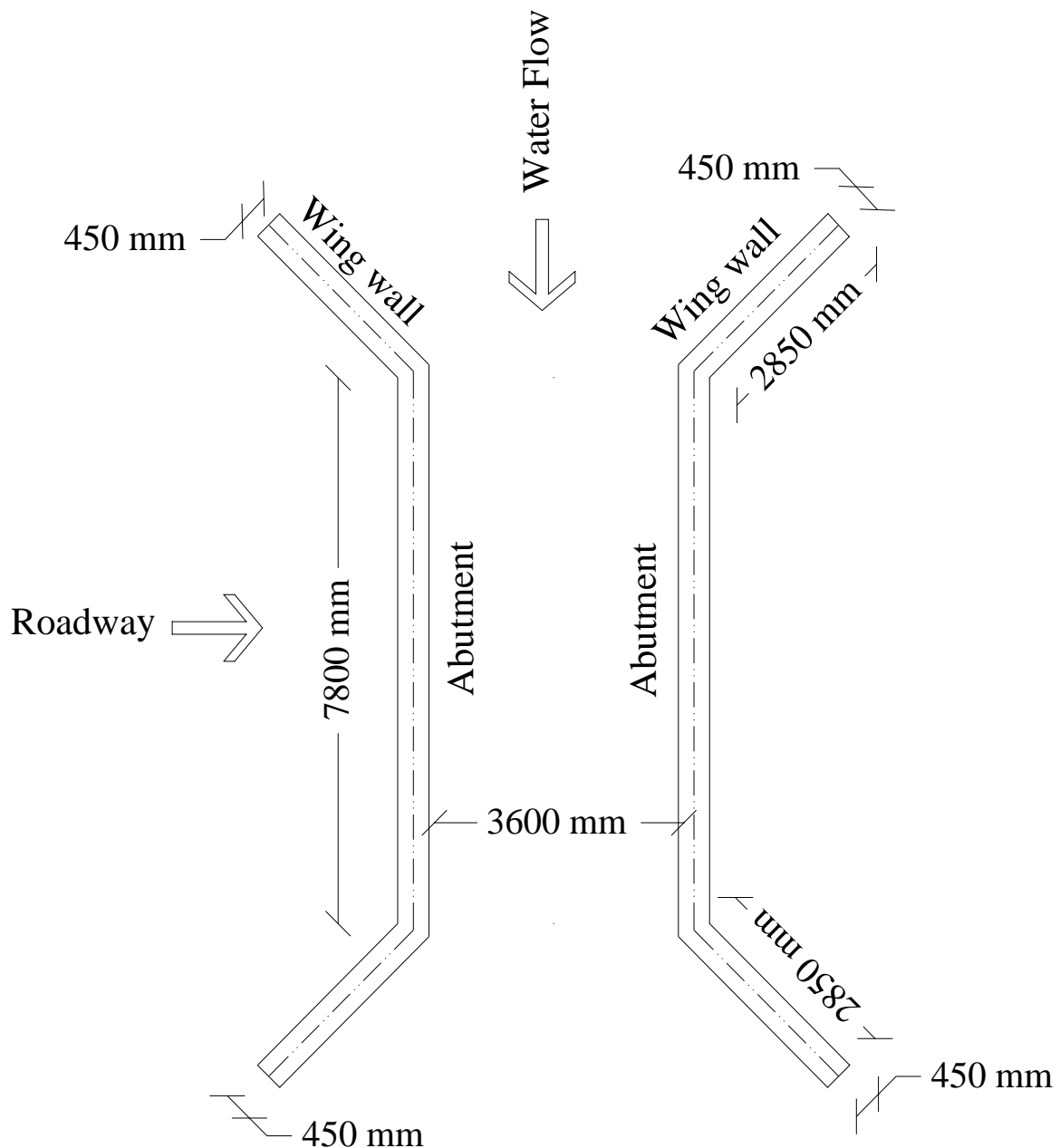


Figure 5.1: Plan of the Culvert.

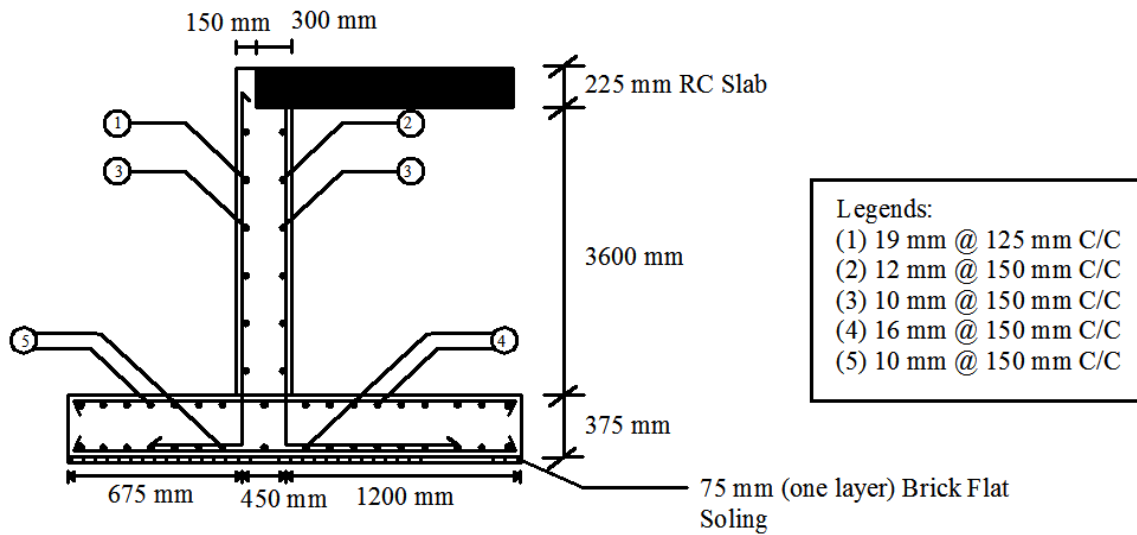


Figure: Sectional Elevation through Abutment

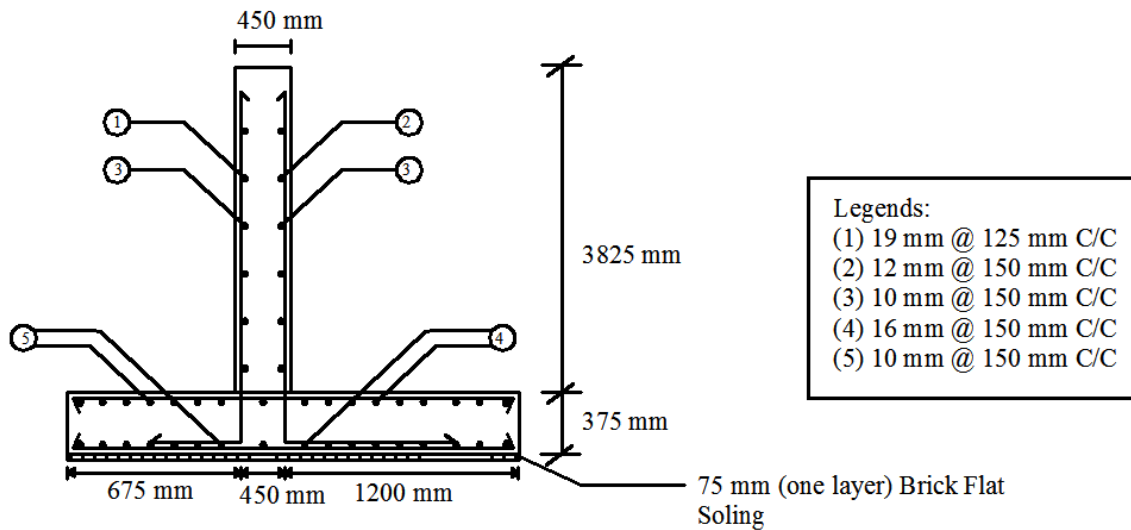


Figure: Sectional Elevation through Wing wall

Figure 5.2: Sectional Views of Culvert

Chapter 6

Plan, Elevation and Section of an Underground Water Reservoir

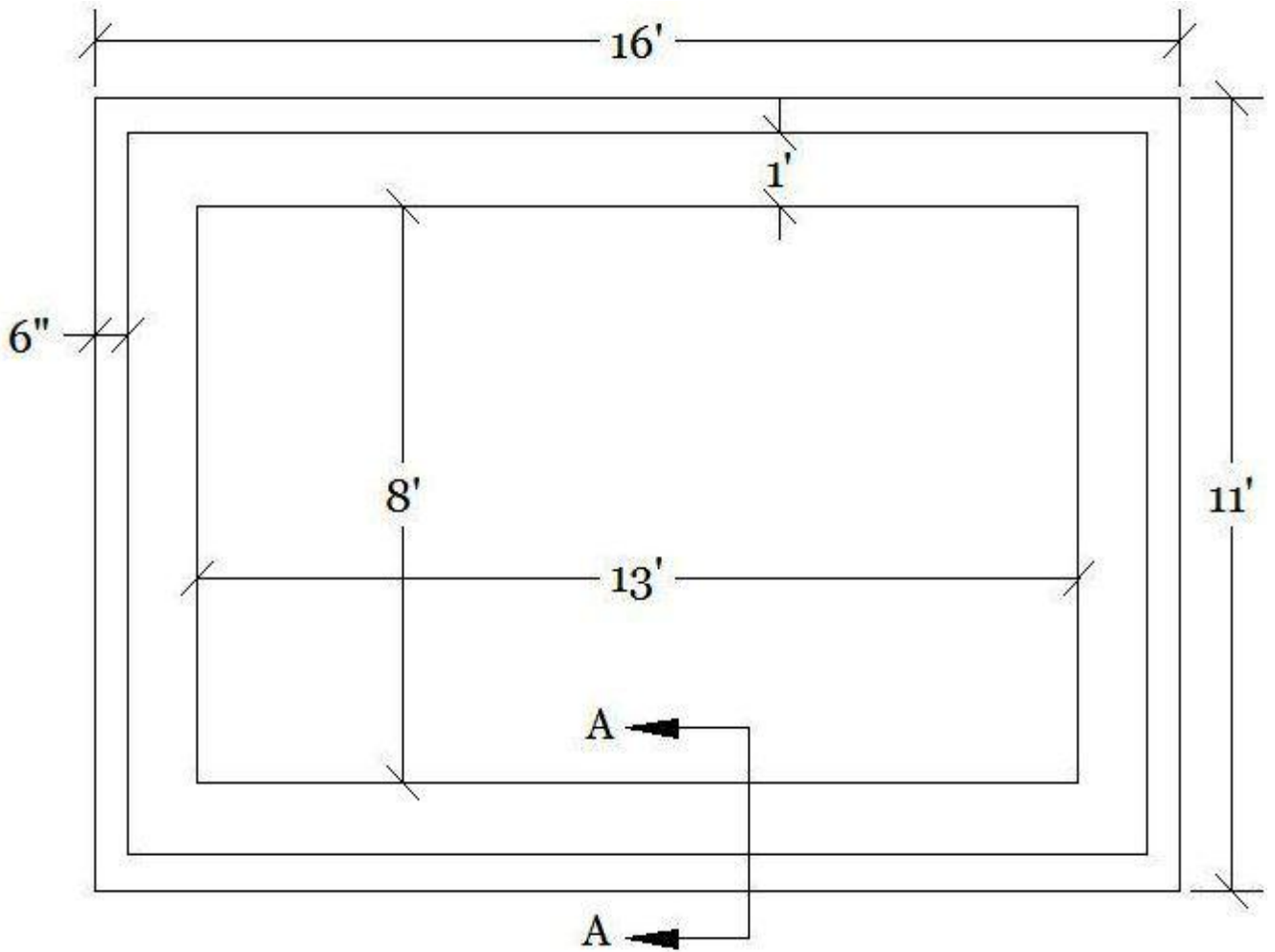


Figure 6.1: Plan of the underground water reservoir

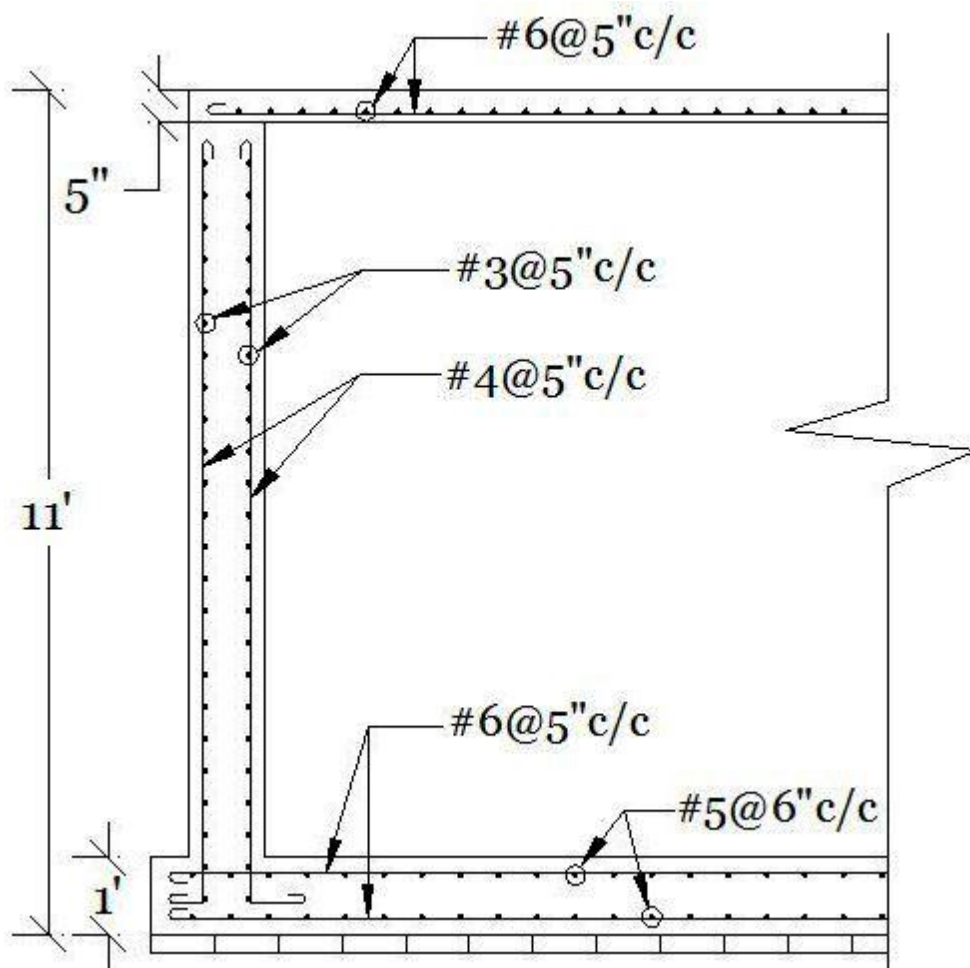
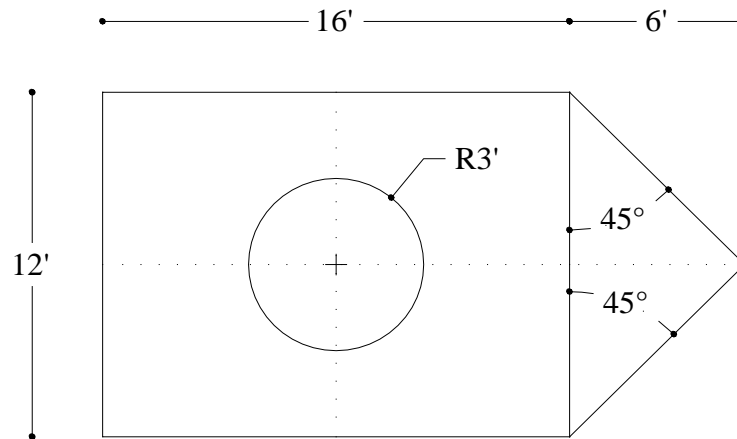


Figure 6.2: Section A-A

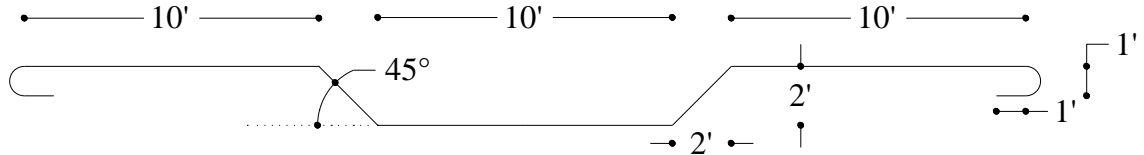
Assignment

Draw the following diagrams using AutoCAD (follow the instructions where given):

1.

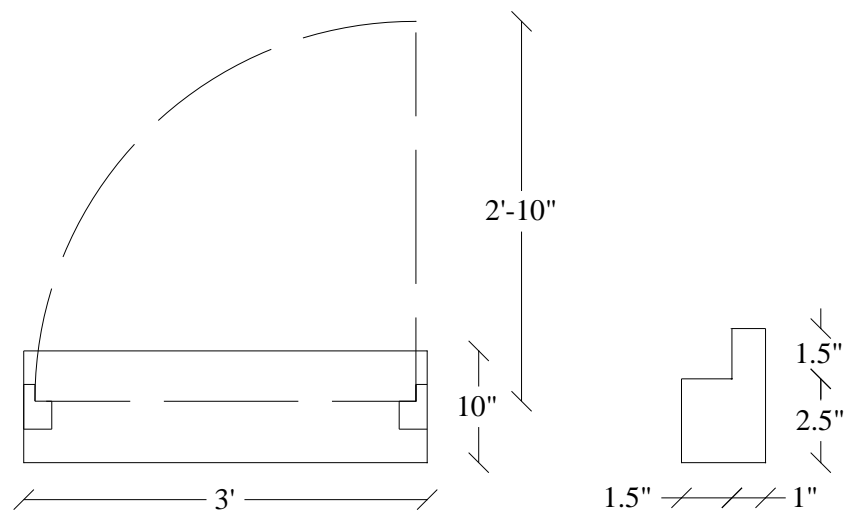


2.



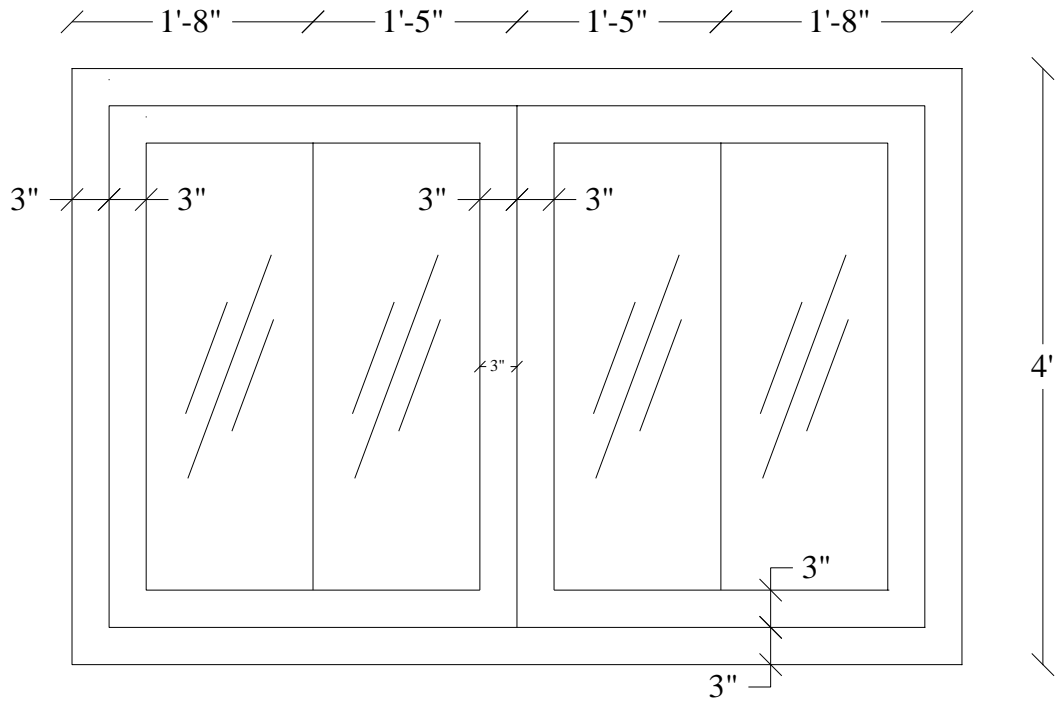
Use Line, Arc / Polyline

3.



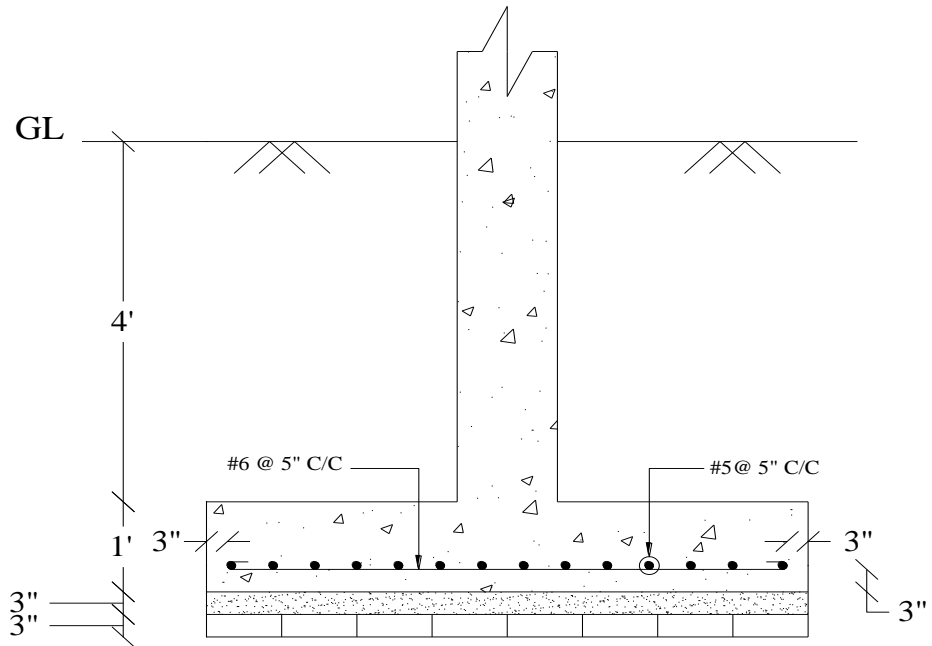
Use Line, Arc

4.



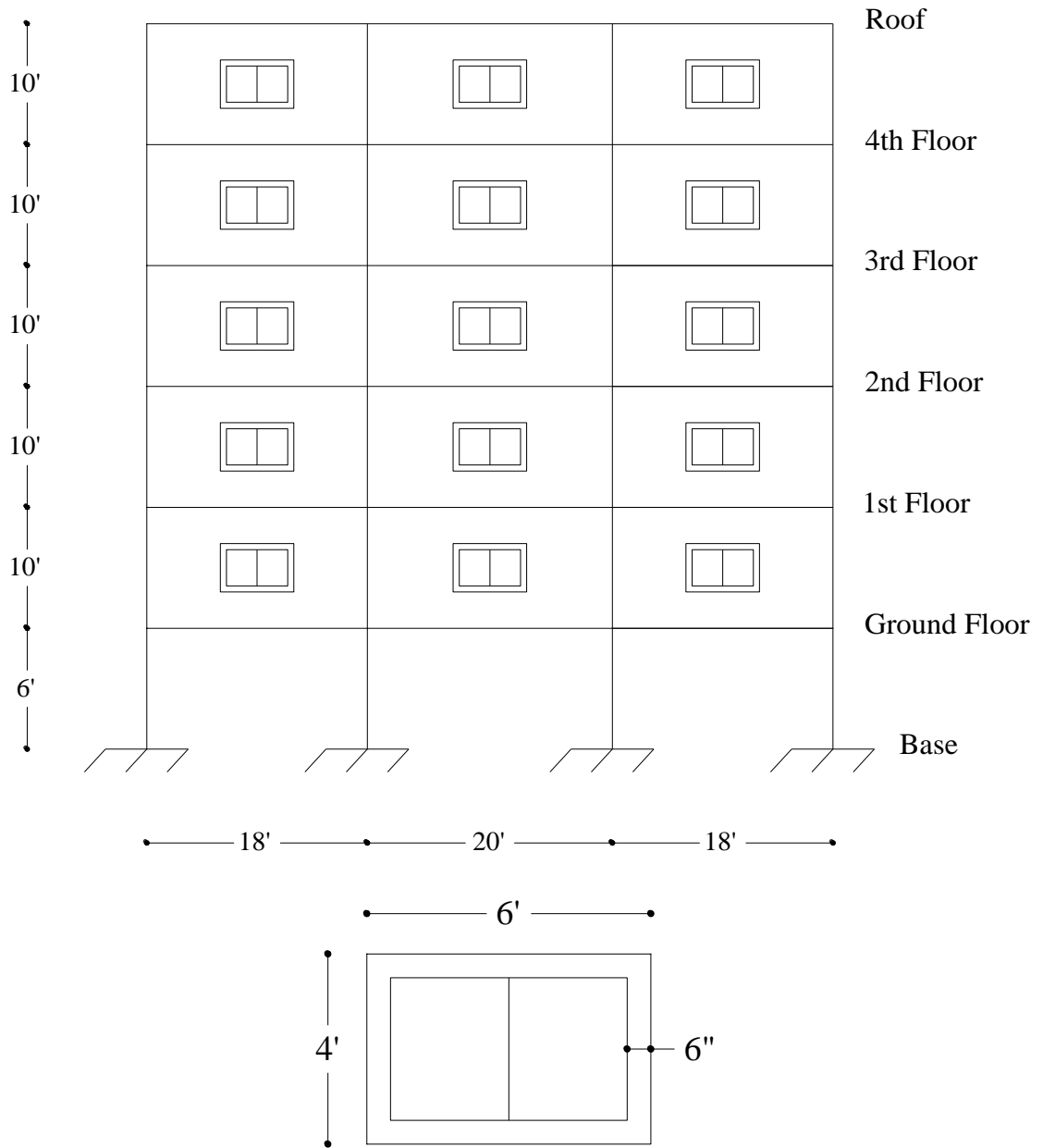
Use Rectangle , Line, Offset

5.



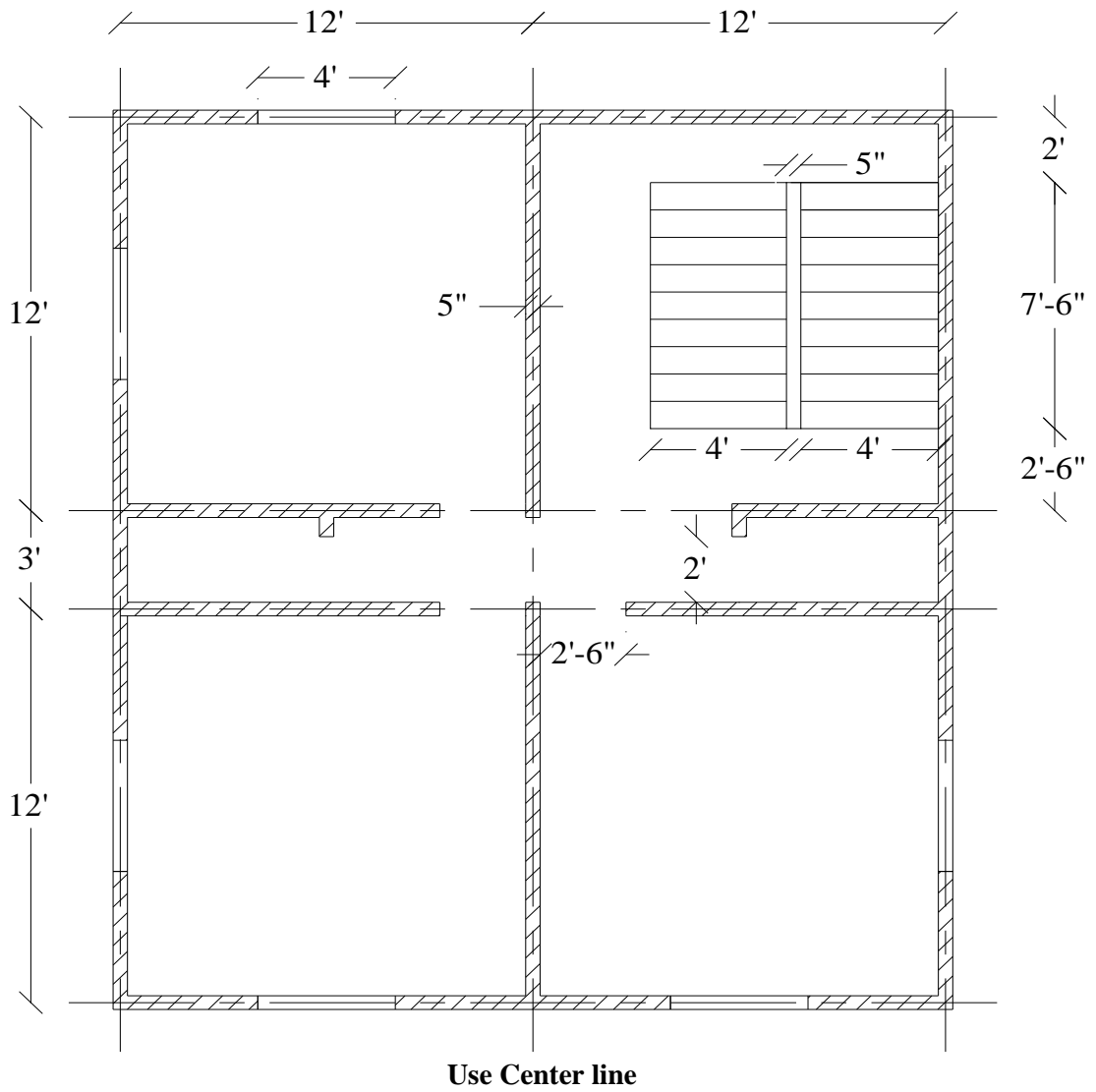
Use Copy(for donut) ,Hatch (Conc. ,Sand)

6.

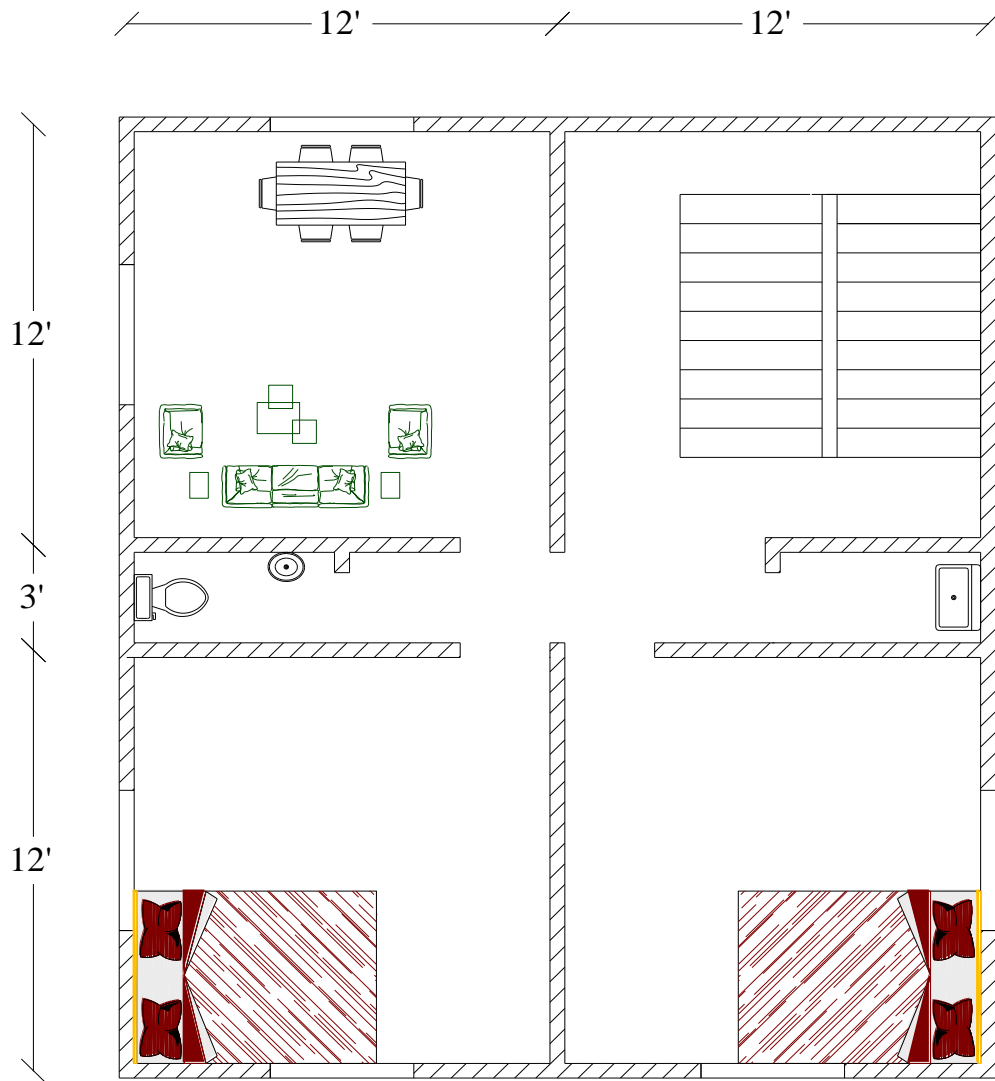


Use Offset, Copy, Scale factor of Dimension Style

7.

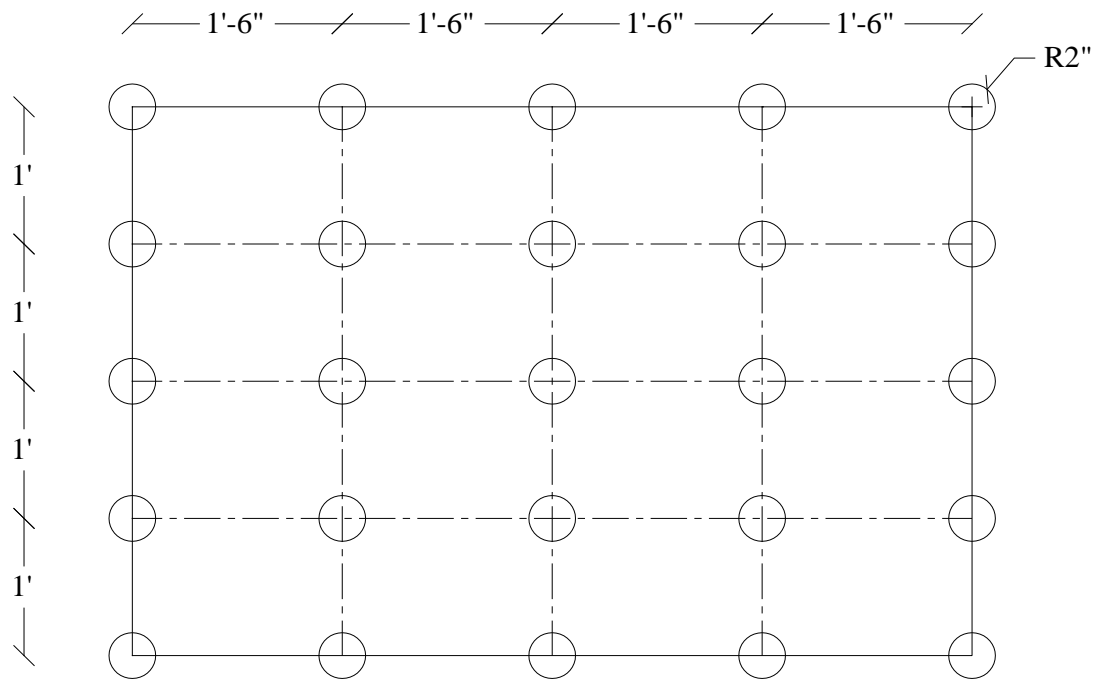


8.



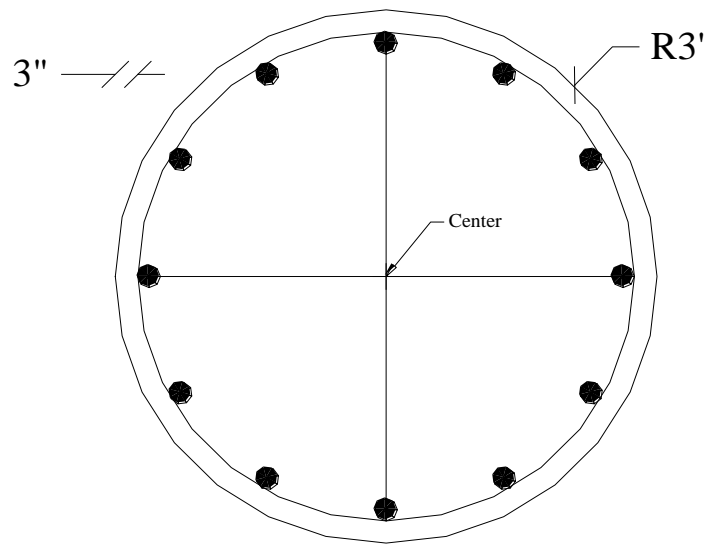
Use Block

9.



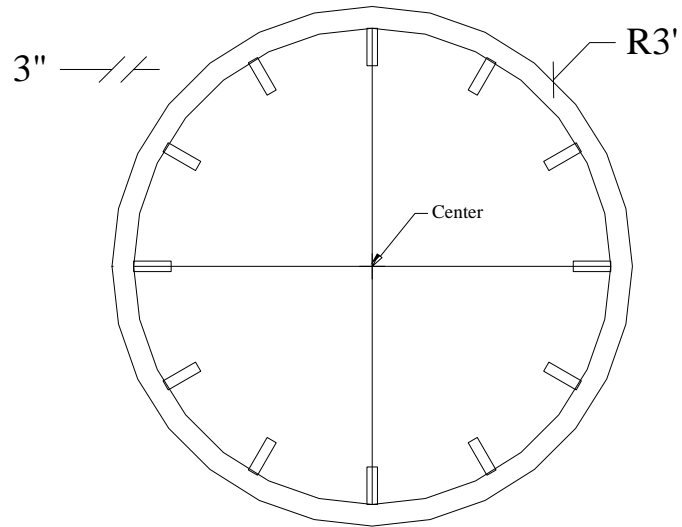
Use Offset, Rectangular Array

10.



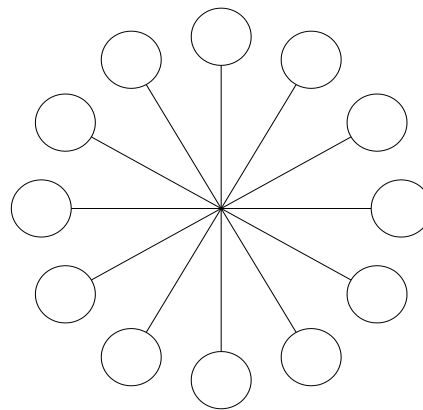
Use Offset, Polar Array

11.



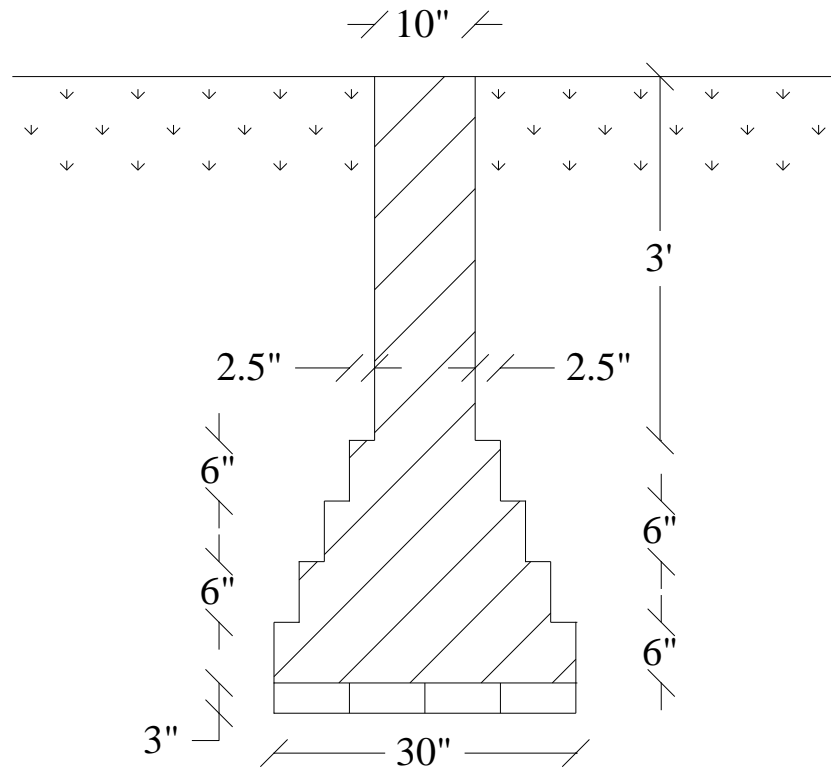
Use Offset, Polar Array

12.



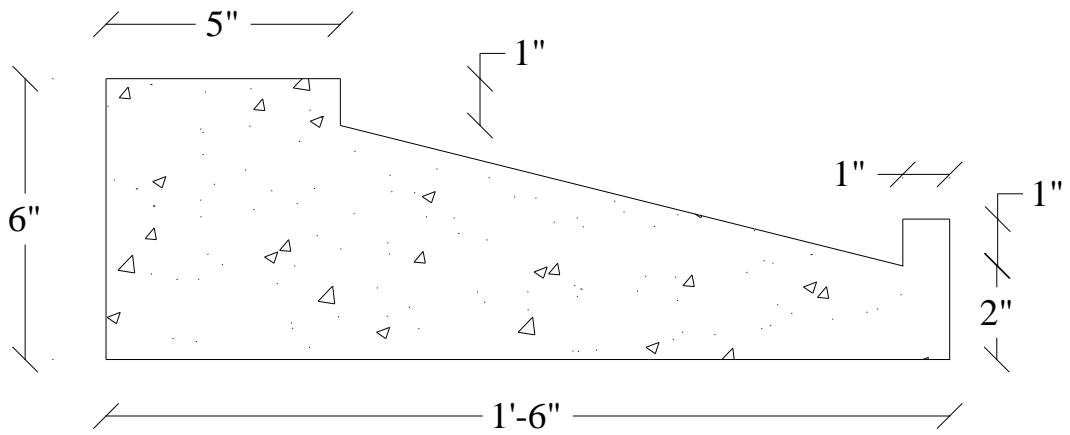
Use Polar Array

13.



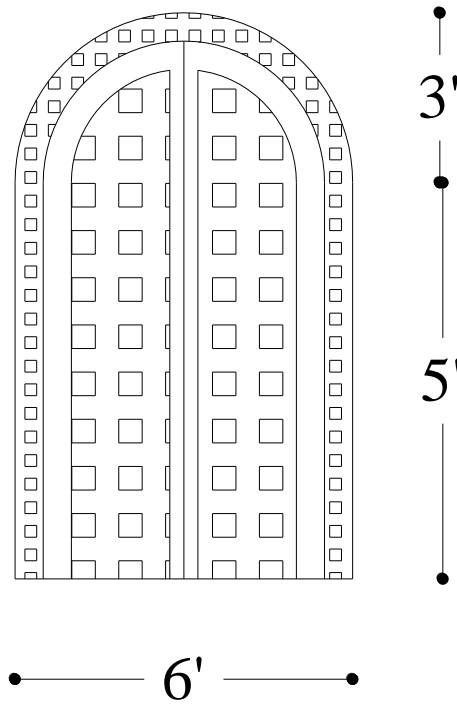
Use Offset, Trim, Hatch (brick)

14.



Use Hatch (Conc.)

15.



Use Line, Arc, Offset, Hatch

References

1. AutoCAD User-guide, 2007