



CE 100

Civil Engineering Drawing Sessional

(Lab Manual)



Department of Civil Engineering
Ahsanullah University of Science and Technology
November, 2017

Preface

This course is designed to provide civil engineering undergraduates with basic understanding of the theory and practice of engineering drawings. Students will learn to read and construct all architectural, structural and other drawings by means of discussions and drawing examples related to existing buildings or projects. It includes lettering, plane geometry, different geometric constructions, types of lines, perspective projections, orthographic projections, structural floor plan of a building and detailing for typical reinforced concrete structural members.

This Lab manual was prepared with the help of “Beginner’s guide to Engineering Drawing” by Dr. E. R. Latifee and some other lecture notes.

Md. Asif Hossain
Department of Civil Engineering
Ahsanullah University of Science and Technology

Updated by
Md. Ajwad Anwar
Sudipta Dey Tirtha
Syed Aaqib Javed
Department of Civil Engineering
Ahsanullah University of Science and Technology

Table of Contents

Traditional Drawing Tools	4
Standard Engineering Lettering	7
Different Geometric Constructions	15
Types of Lines.....	22
Perspective Projections.....	33
Orthographic Projections and Isometric Drawing	42
Structural drawing – Plan view, Elevation view and Cross sectional view	55
Structural drawing –Isolated footing and beam longitudinal and cross sectional views	61
Structural drawing – Slab and Stair reinforcement detailing	64
Appendix 1	67
Appendix 2	72

Topic 1

Traditional Drawing Tools



Drawing

A drawing is a graphic representation of an object, or a part of it, and is the result of creative thought by an engineer or technician. When one person sketches a rough map in giving direction to another, this is graphic communication. Graphic communication involves using visual materials to relate ideas. Drawings, photographs, slides, transparencies, and sketches are all forms of graphic communication. Any medium that uses a graphic image to aid in conveying a message, instructions, or an idea is involved in graphic communication.

Engineering drawing:

The engineering drawing, on the other hand, is not subtle, or abstract. It does not require an understanding of its creator, only an understanding of engineering drawings. An engineering drawing is a means of clearly and concisely communicating all of the information necessary to transform an idea or a concept in to reality. Therefore, an engineering drawing often contains more than just a graphic representation of its subject. It also contains dimensions, notes and specifications.

Drawing Sheets

A Series Formats (mm)	
A0	841 × 1189
A1	594 × 841
A2	420 × 594
A3	297 × 420
A4	210 × 297
A5	148 × 210
A6	105 × 148
A7	74 × 105

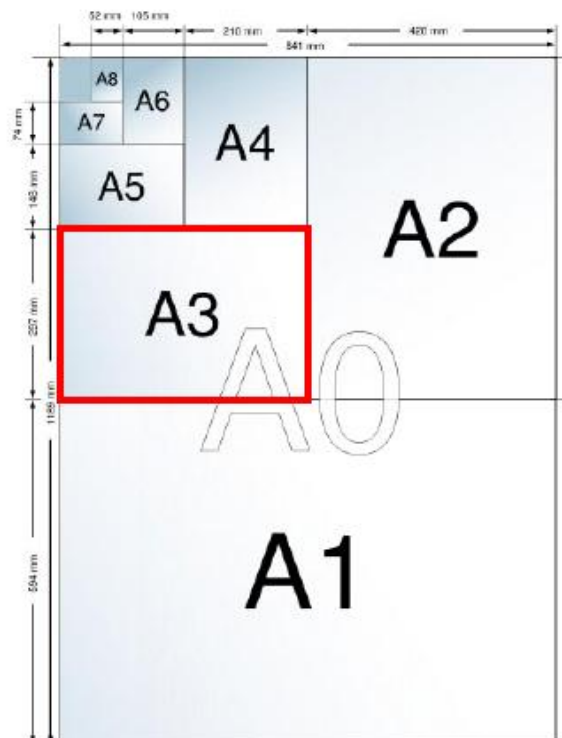

DRAWING TOOLS



DRAWING TOOLS



1. T-Square

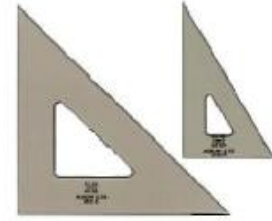

2. Triangles

DRAWING TOOLS



3. Adhesive Tape



4. Pencils

DRAWING TOOLS



5. Sandpaper



6. Compass

DRAWING TOOLS



7. Pencil Eraser



8. Erasing Shield

DRAWING TOOLS



9. Circle Template



10. Tissue paper

DRAWING TOOLS



11. Sharpener



12. Clean paper

Topic 2

Standard Engineering Lettering

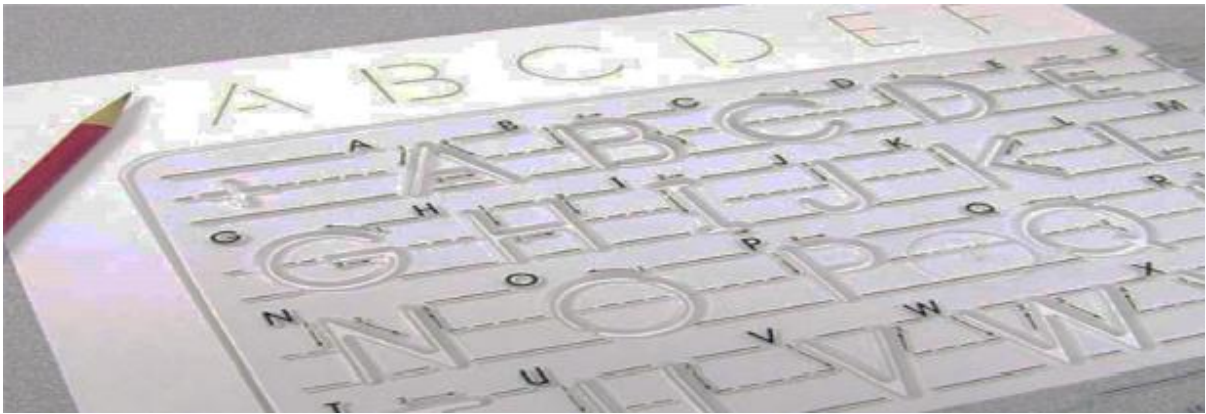

Elements of Engineering Drawing

Engineering drawing are made up of *graphics language* and *word language*.

Graphics language: Describe a shape (mainly).

Word language: Describe an exact size, location and specification of the object.

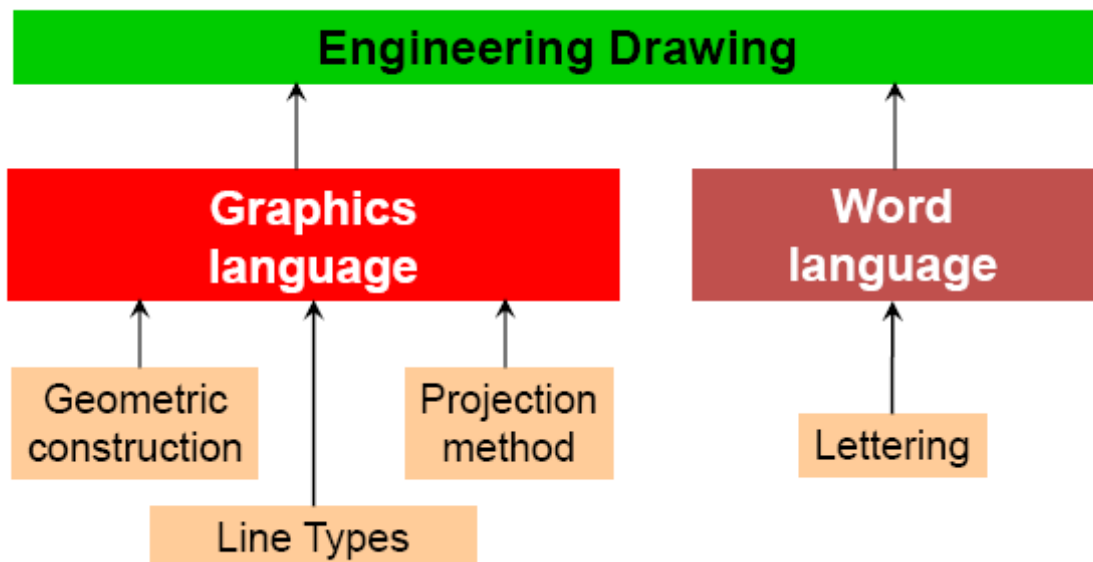
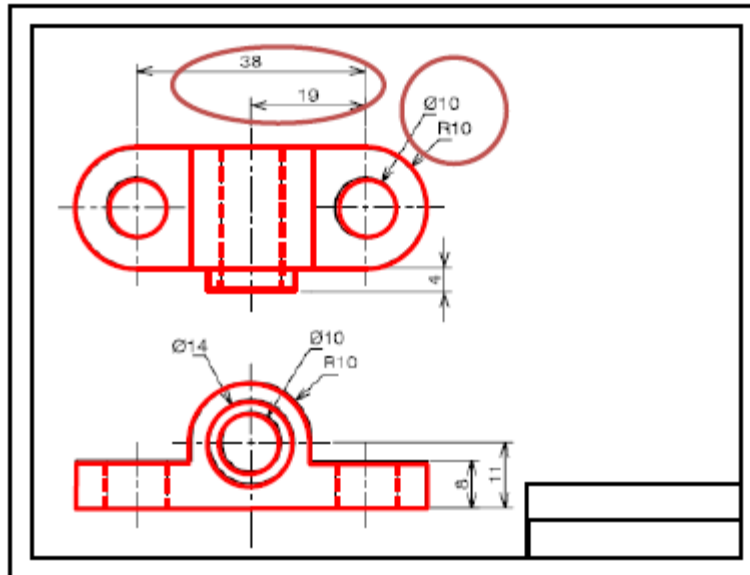

Lettering in Engineering Drawing

Lettering is used to provide easy to read and understand information to supplement a drawing in the form of notes and annotations. Lettering is an essential element in both traditional drawing and Computer Aided Design (CAD) drawing. Thus, it must be written with:

Legibility – shape & space between letters and words.

Uniformity – size & line thickness.

Types of Lettering

The two types of lettering are:

1. Double Stroke Lettering: In Double Stroke Lettering the line width is greater than that of Single Stroke Lettering.

Double Stroke Lettering is further divided into:

a) *Double Stroke Vertical Gothic Lettering.*

b) *Double Stroke Inclined Gothic Lettering.*

A stencil is mostly used when hand drawing double stroked letters.

2. Single Stroke Lettering: Thickness in single stroke lettering is obtained by a single stroke of pencil or ink pen. It is further divided into:

(a) *Single Stroke Vertical Gothic Lettering.*

(b) *Single Stroke Inclined Gothic Lettering.*

Conventions for Lettering

- Use all **CAPITAL LETTERS**.
- Use ***even pressure*** to draw **precise, clean lines**.
- Use ***one stroke*** per line.
- **Horizontal Strokes** are drawn ***left to right***.
- **Vertical Strokes** are drawn ***downward***.
- **Curved strokes** are drawn ***top to bottom*** in one continuous stroke on each side.
- Use The ***Single-stroke, Gothic Style of Lettering***.
- Always ***Skip A Space*** Between Rows Of Letters.
- Always Use ***Very Light Guide Lines***.
- **Fractions** Are Lettered ***Twice the Height Of Normal Letters***.
- **Fraction Bars** Are Always ***Drawn Horizontal***.
- Use a ***Medium Lead*** For ***Normal Lettering***.
- Use a ***Hard Lead*** For Drawing ***Guide Lines***.

Placement of Text on Engineering Drawings

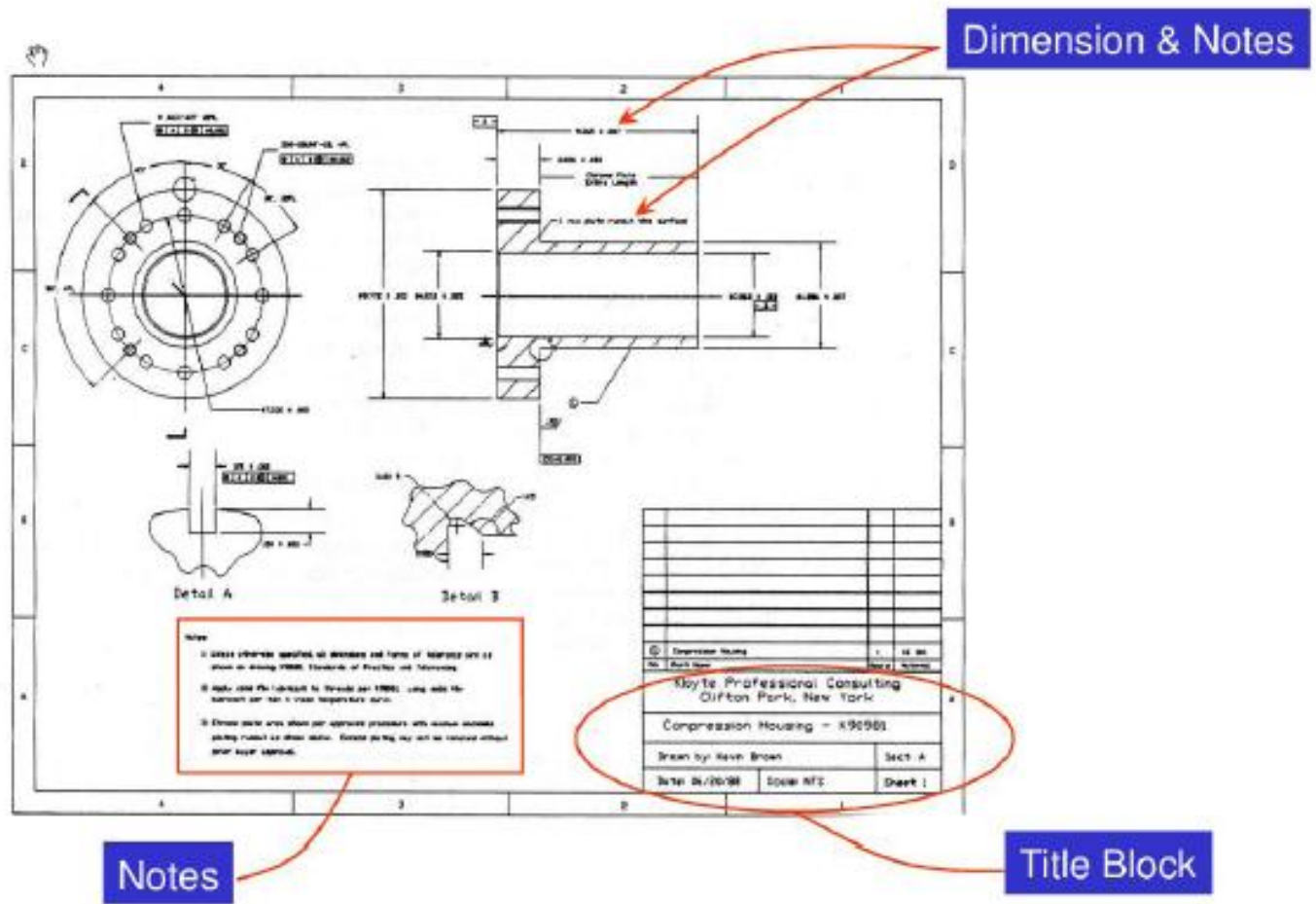

Basics of Single Stroking

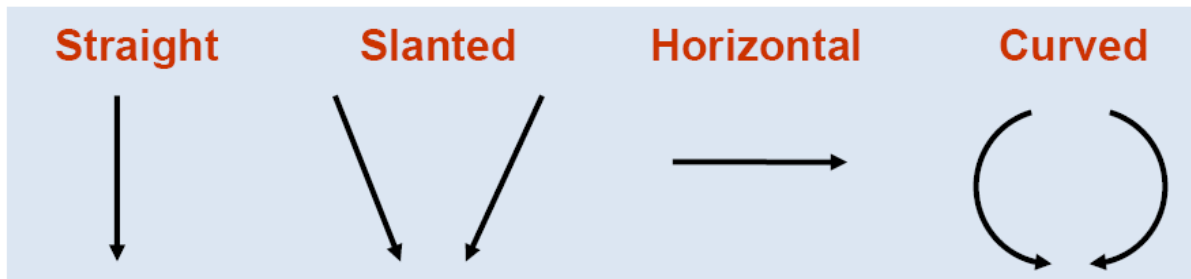

Examples

“I” letter



“A” letter

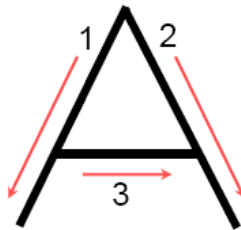

“B” letter

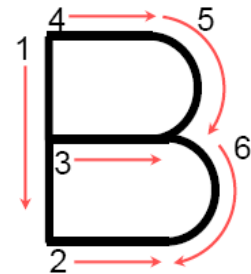

Spacing

Uniformity in spacing of letters is a matter of equalizing spaces by eye.

- The background area between letters, not the distance between them, should be approximately equal.
- Words are spaced well apart, but letters within words should be spaced closely.



- For either upper case or lower-case lettering, make the spaces between words approximately equal to a capital O.



Space between letters

1. Straight - Straight



3. Straight - Slant

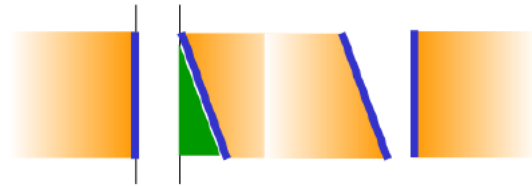

2. Straight - Curve

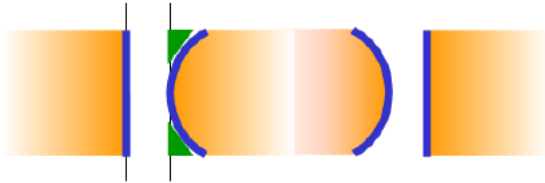

4. Curve - Curve

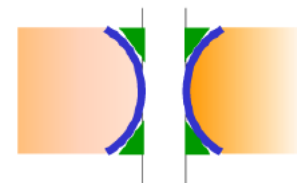

5. Curve - Slant



6. Slant - Slant



7. The letter "L" and "T"

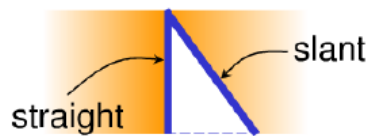
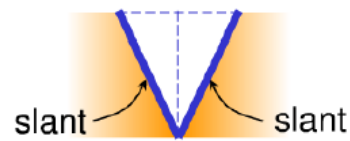

Drawing scales

Scale is the ratio of the linear dimension of an element of an object shown in the drawing to the real linear dimension of the same element of the object.

Designation of a scale consists of the word “SCALE” followed by the indication of its ratio, as follows:

SCALE 1:1 for full size

SCALE **X**:1 for *enlargement* scales ($X > 1$)

SCALE 1:**X** for *reduction* scales ($X > 1$)

Dimension numbers shown in the drawing correspond to “true size” of the object and they are independent of the scale used in creating that drawing.

Try with one-fourth (0.25) inches distance between the lines, in both the directions (X and Y axes)

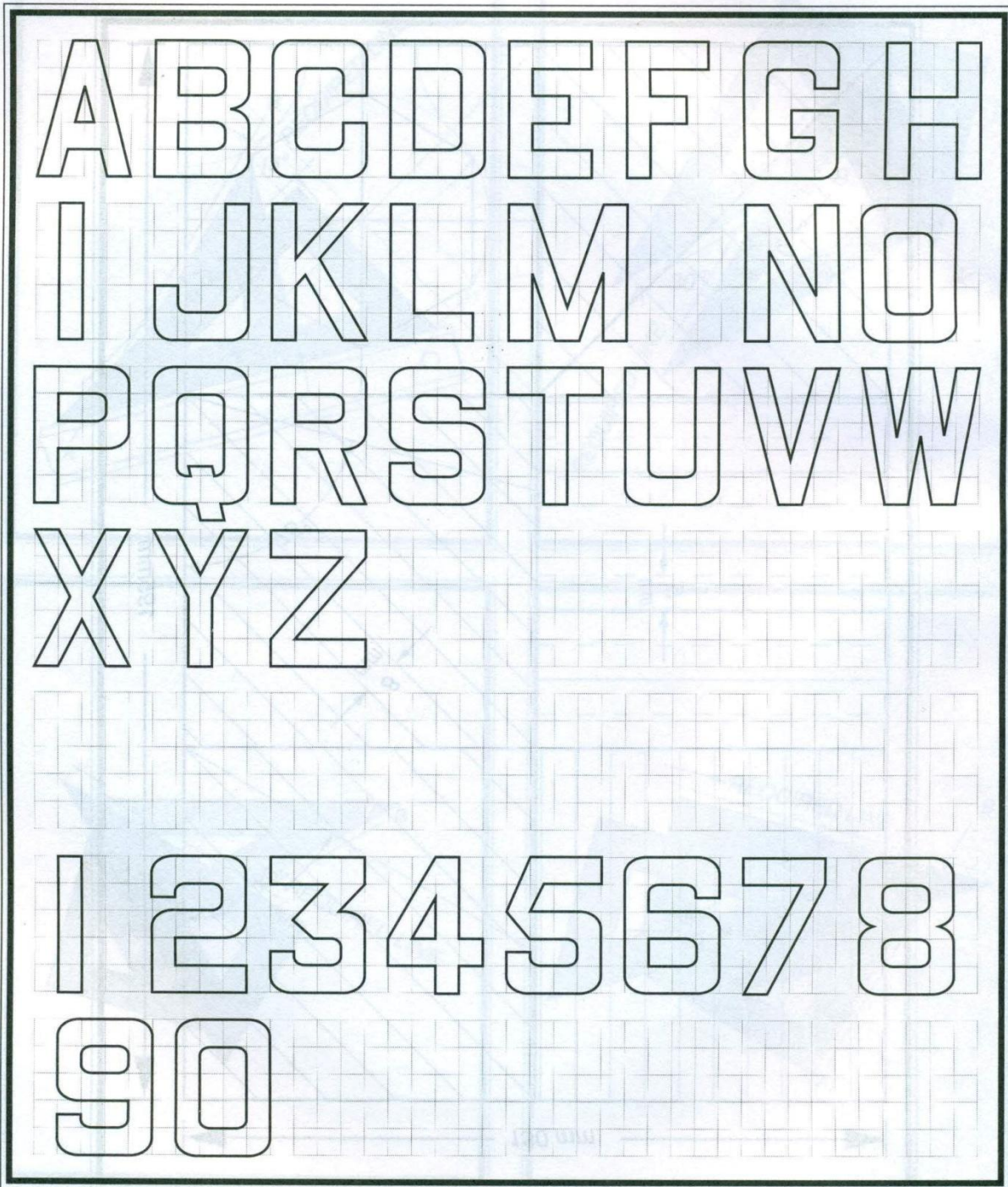

Topic 3

Different Geometric Constructions

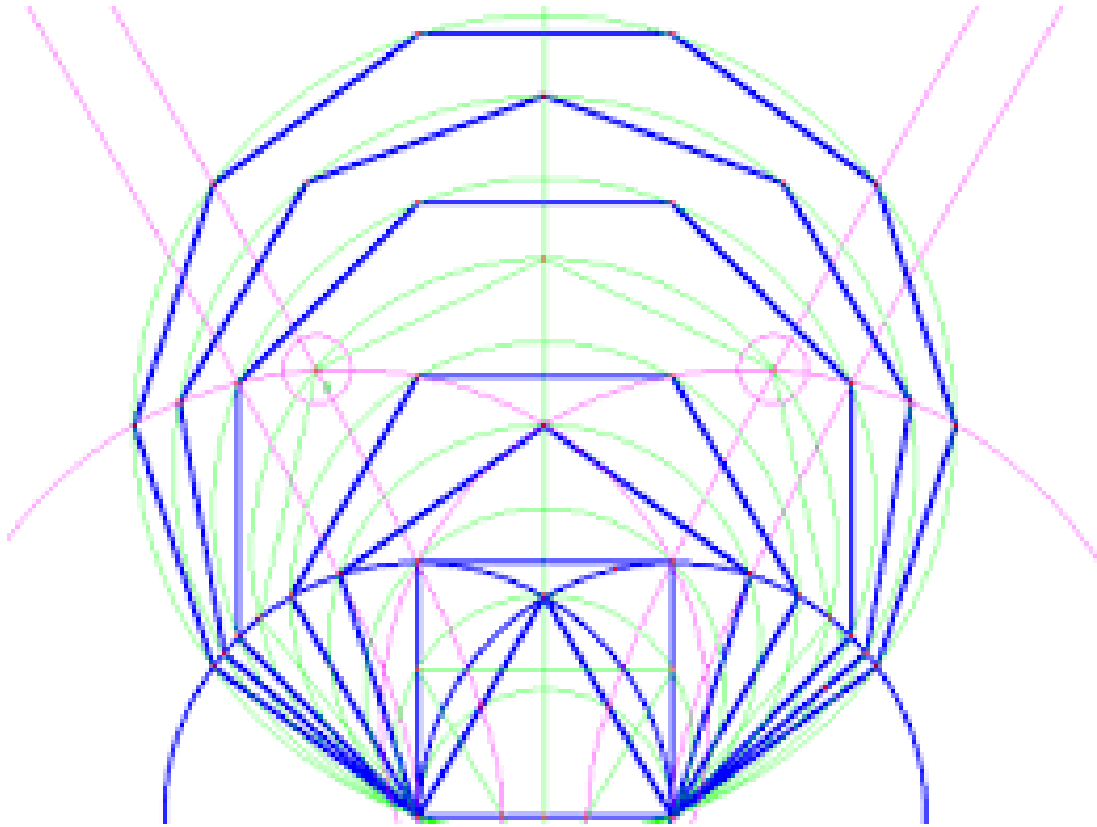

Objectives:

At the end of this chapter students should be able to:

- Define geometric nomenclatures like angles, lines etc
- Discuss the steps to construct different geometric figures like lines, arcs, polygon, ellipse etc.

Introduction :

Strict interpretation of geometric construction allows use of only the compass and an instrument for drawing straight lines, and with these, the geometer, following mathematical theory, accomplishes his solutions. In technical drawing, the principles of geometry are employed constantly, but instruments are not limited to the basic two as T-squares, triangles, scales, curves etc. are used to make constructions with speed and accuracy. Since there is continual application of geometric principles, the methods given in this chapter should be mastered thoroughly.

GEOMETRIC NOMENICLATURE

A. POINTS IN SPACE

A point is an exact location in space or on a drawing surface. A point is actually represented on the drawing by a crisscross at its exact location. The exact point in space is where the two lines of the crisscross intersect. When a point is located on an existing line, a light, short dashed line or cross bar is placed on the line at the location of the exact point. Never represent a Point on a drawing by a dot; except for sketching locations.

B. LINE

Lines are straight elements that have no width, but are infinite in length (magnitude), and they can be located by two points which are not on the same spot but fall along the line. Lines may be straight lines or curved lines. A straight line is the shortest distance between two points. It can be drawn in any direction. If a line is indefinite, and the ends are not fixed in length, the actual length is a matter of convenience. If the end points of a line are important, they must be marked by means of small, mechanically drawn crossbars, as described by a pint in space. Straight lines and curved lines are considered parallel if the shortest distance between them remains constant. The symbol used for parallel line is //.

Lines, which are tangent and at 90 degree are considered perpendicular. The symbol for perpendicular line is \perp .

C. ANGLES

An angle is formed by the intersection of two lines. There are three major kinds of angles: right angles, acute angles and obtuse angles. The right angle is an angle of 90°, an acute angle is an angle less than 90°, and an obtuse angle is an angle more than 90°. A straight line is 180°. The symbol for an angle is \angle (singular) and \angle 's (Plural). To draw an angle, use the drafting machine, a triangle, or a protractor.

D. TRIANGLES

A triangle is a closed plane figure with three straight sides and their interior angles sum up exactly 1800. The various kinds of triangles: a right triangle, an equilateral triangle, an isosceles triangle, and an obtuse angled triangle.

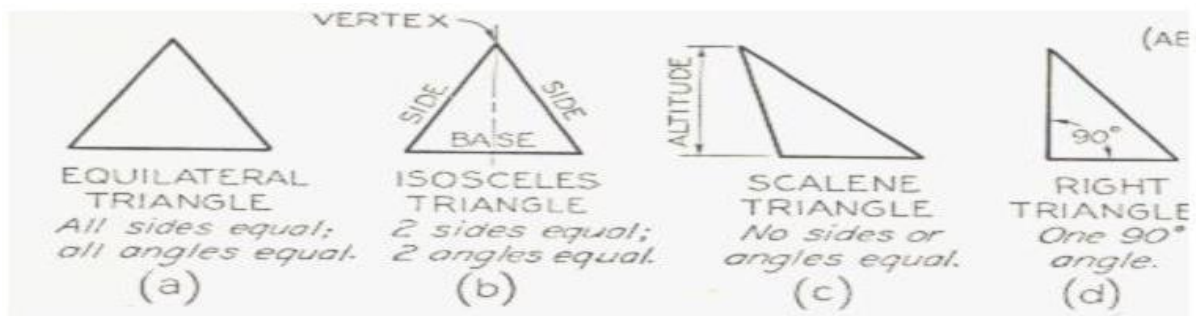

E. QUADRIALTERAL

It is a plane figure bounded by four straight sides. When opposite sides are parallel, the quadrilateral is also considered to be a parallelogram.

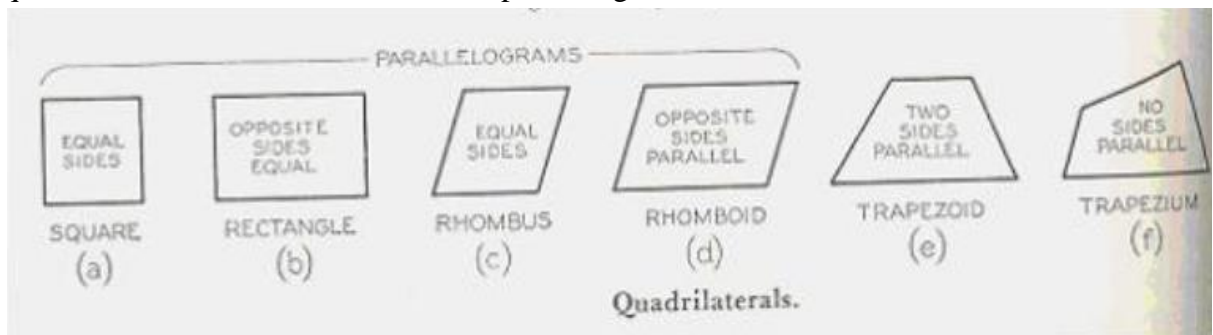

F. POLYGON

A polygon is a closed plane figure with three or more straight sides. The most important of these polygons as they relate to drafting are probably the triangle with three sides, square with four sides, the hexagon with six sides, and the octagon with eight sides.



F1. Regular Pentagon

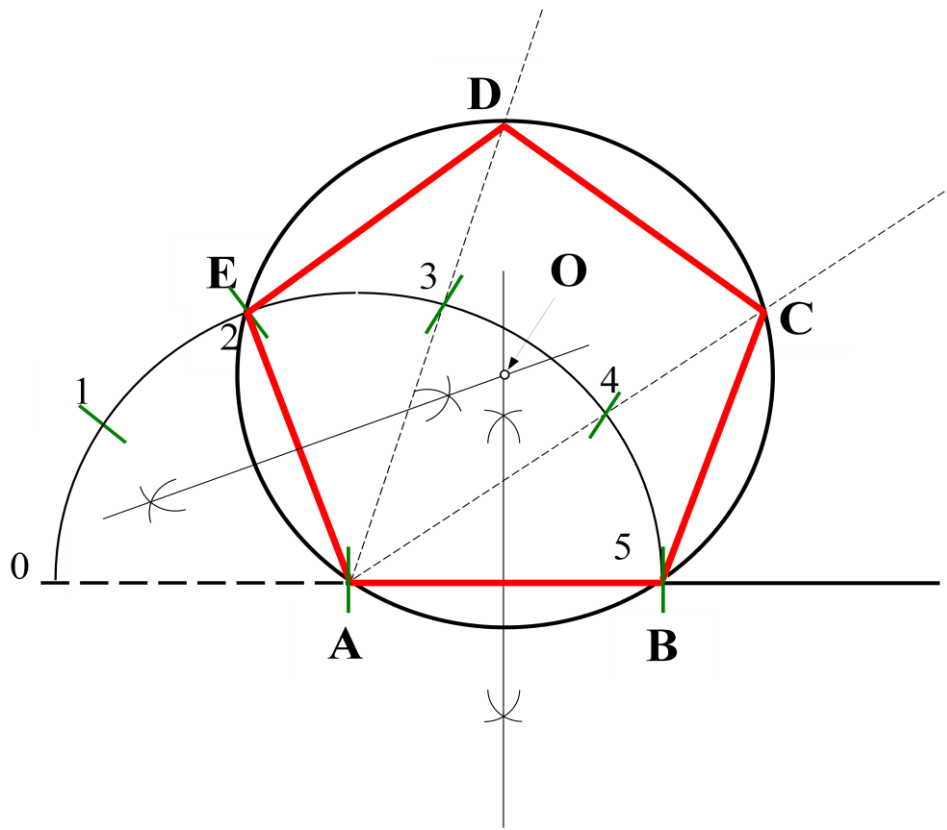

F2. Regular Hexagon

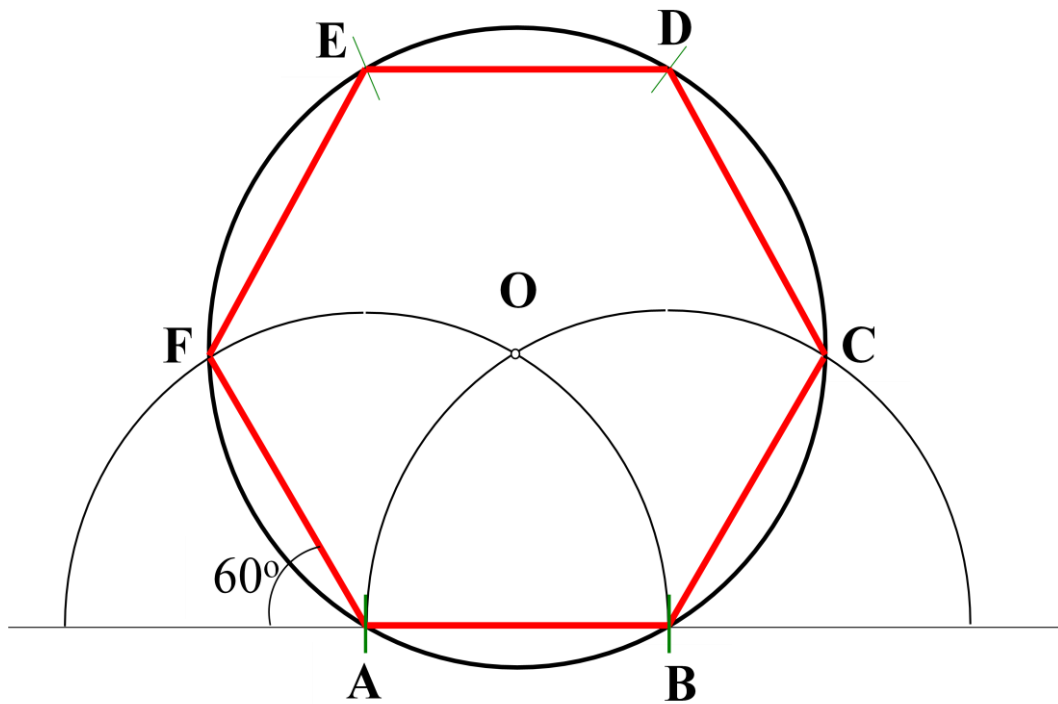

F3. Regular Octagon

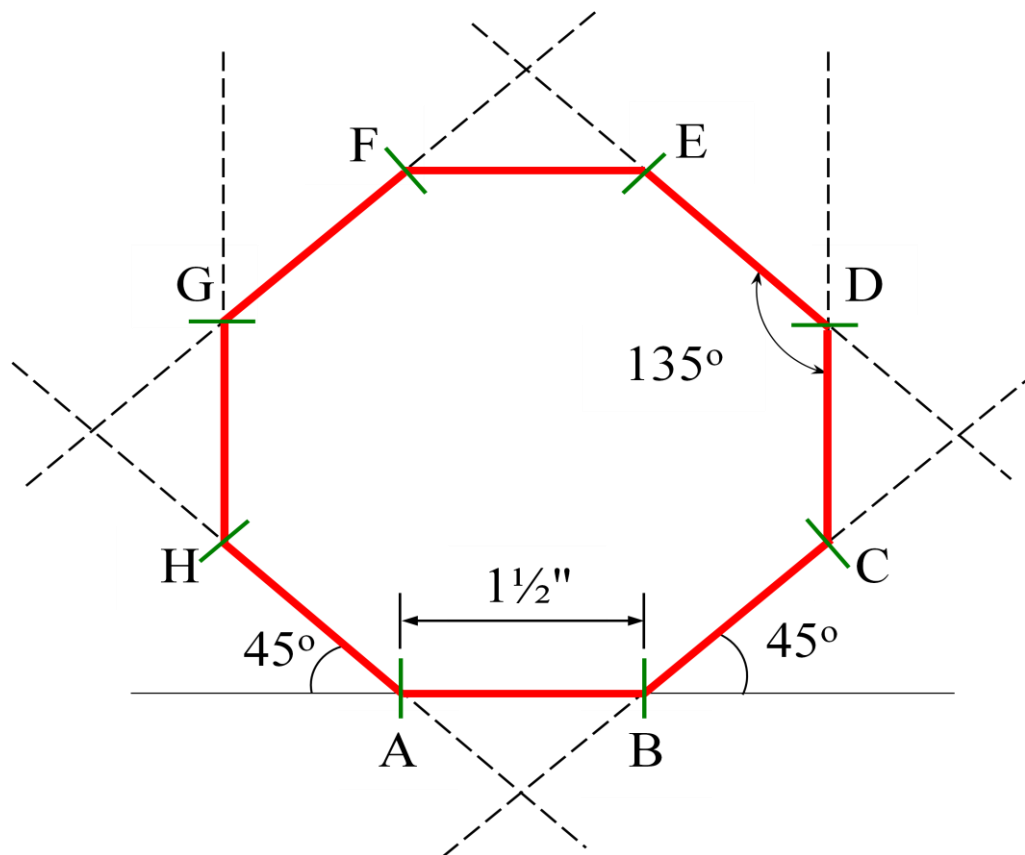

G1. Ellipse (Parallelogram Method)

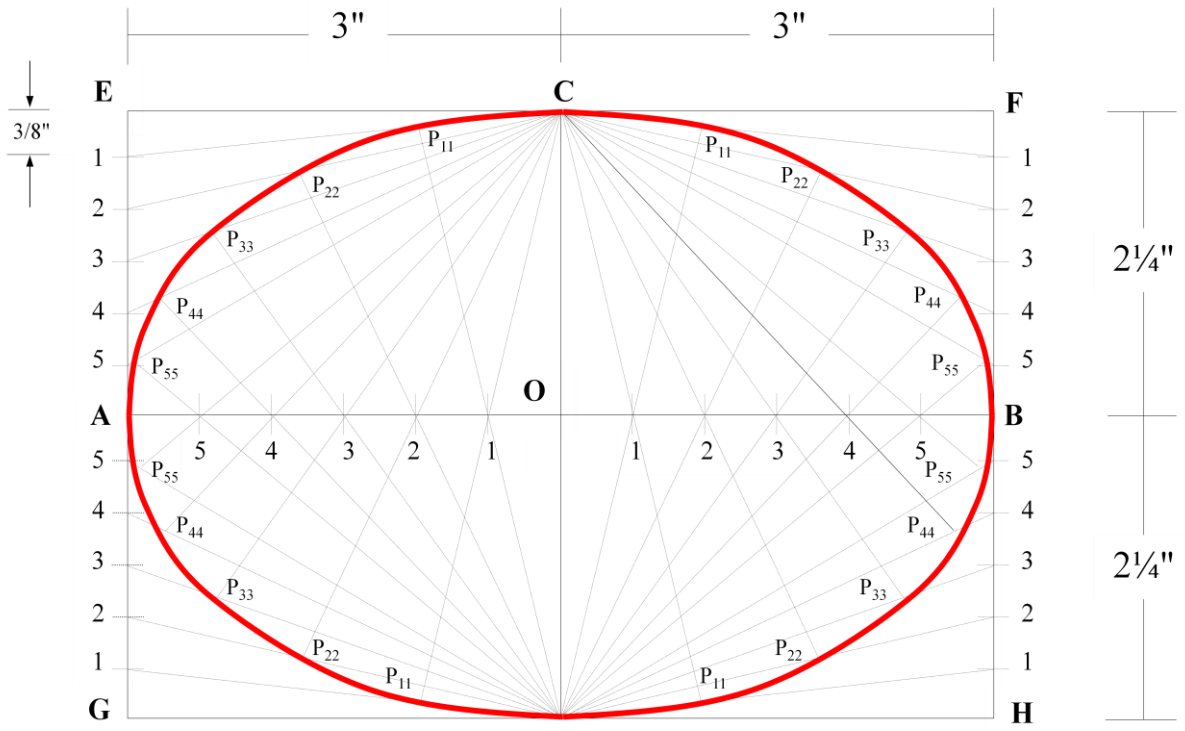

G2. Ellipse Concentric Circles Method

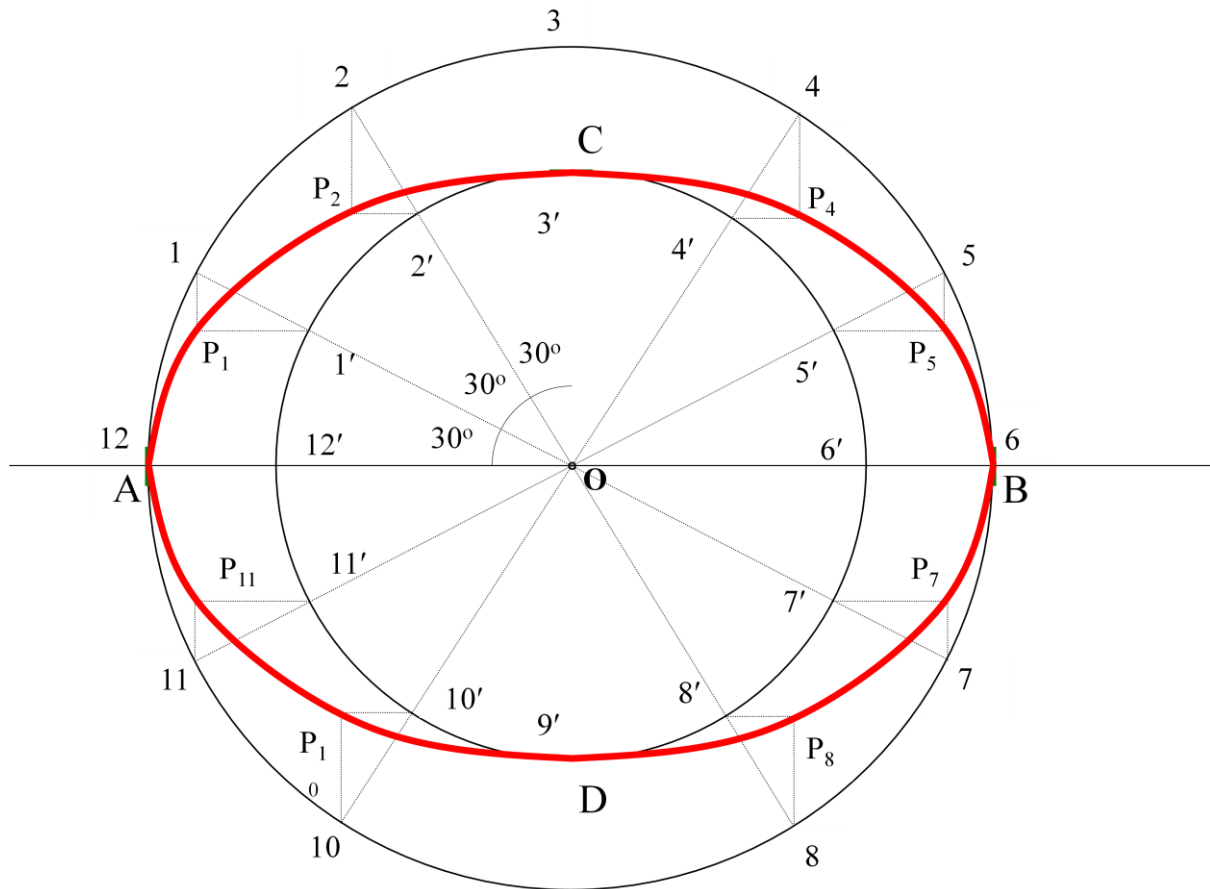

H. Hyperbola

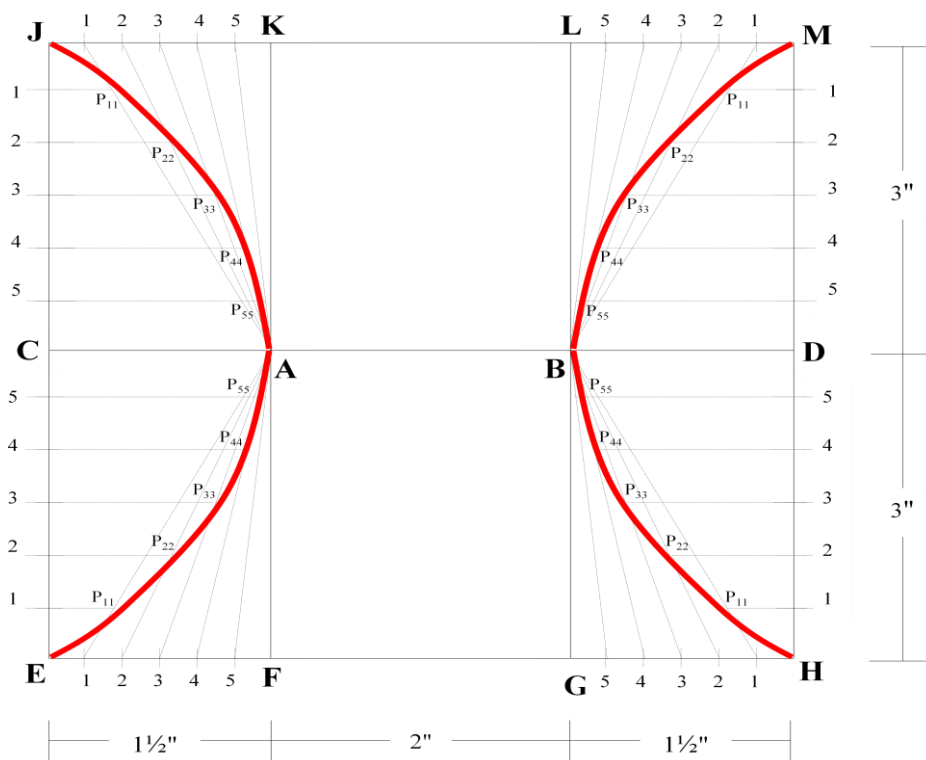

I. PARABOLA

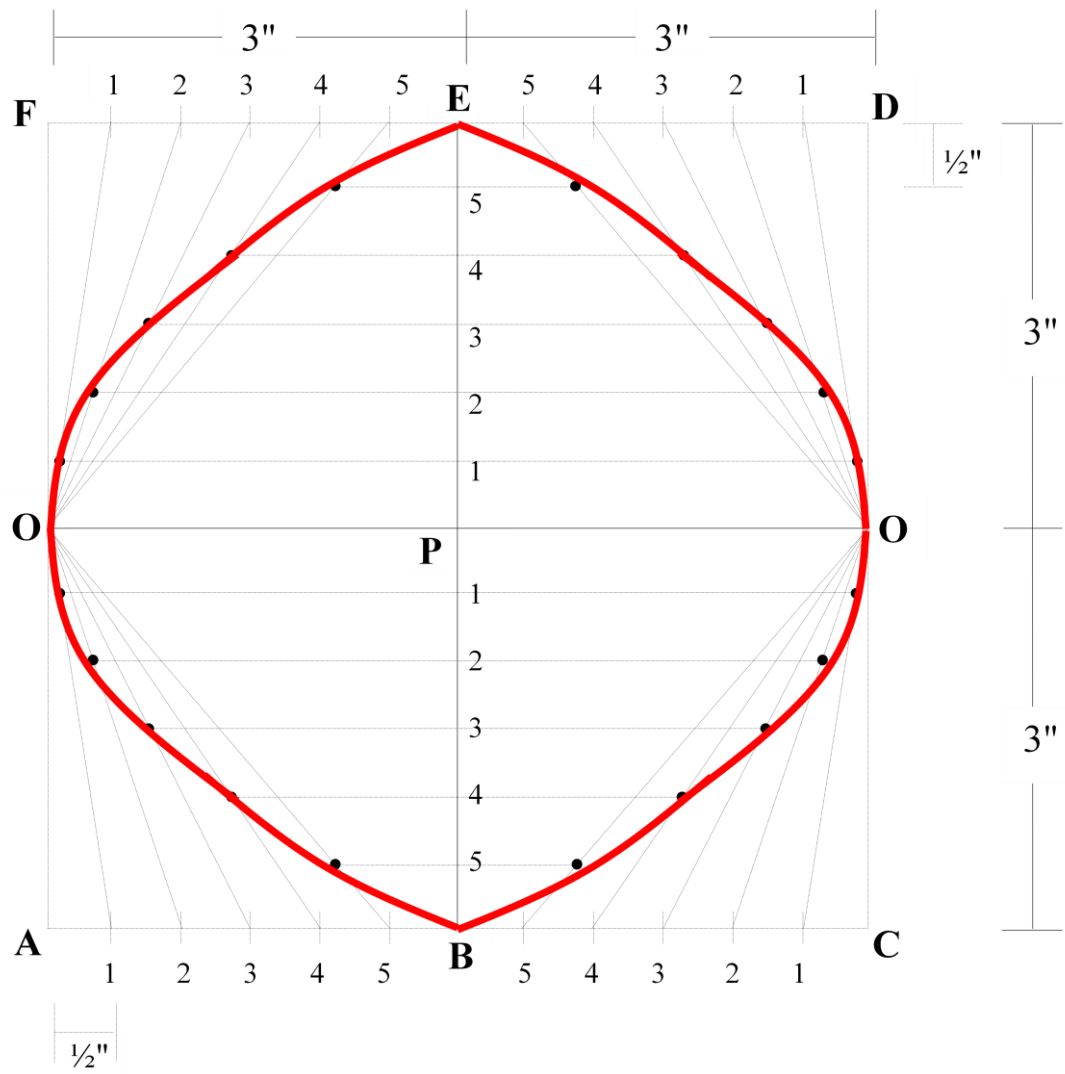



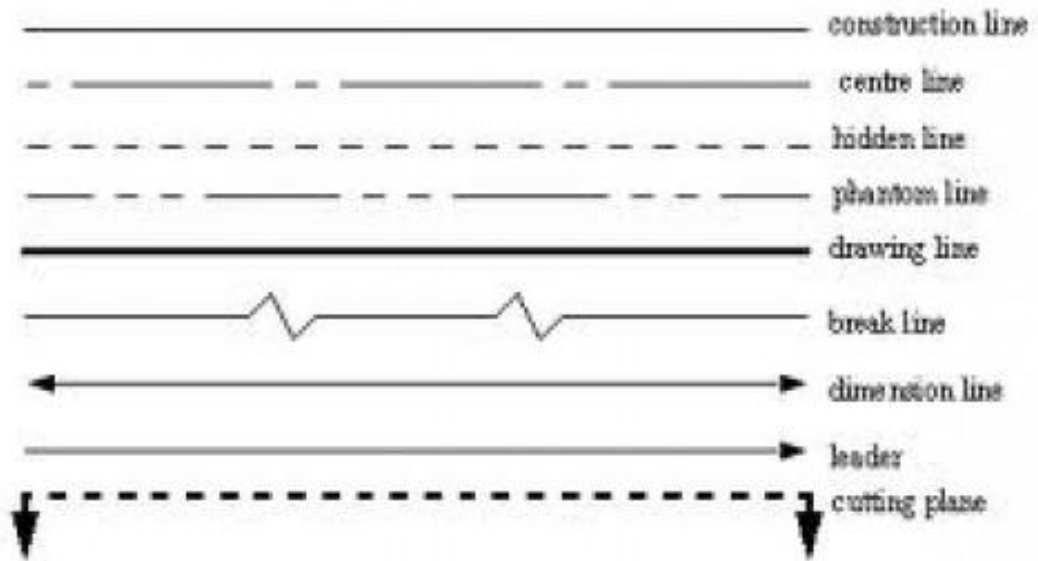

Topic 4

Types of Lines



Introduction to Types of Lines

Thickness	Thick	Thin	
Style	Visible line		1. Dimension line 2. Extension line 3. Leader line
Continuous			Hidden line
Dash			
Chain			Center line

1. **Visible line** represent features that can be seen in the current view.
2. **Dimension line**
Extension line
Leader line indicate the sizes and location of features.
3. **Hidden line** represent features that cannot be seen in the current view.
4. **Center line** represents symmetry, path of motion, centers of circles, axis of axisymmetrical parts.

Main Line Types

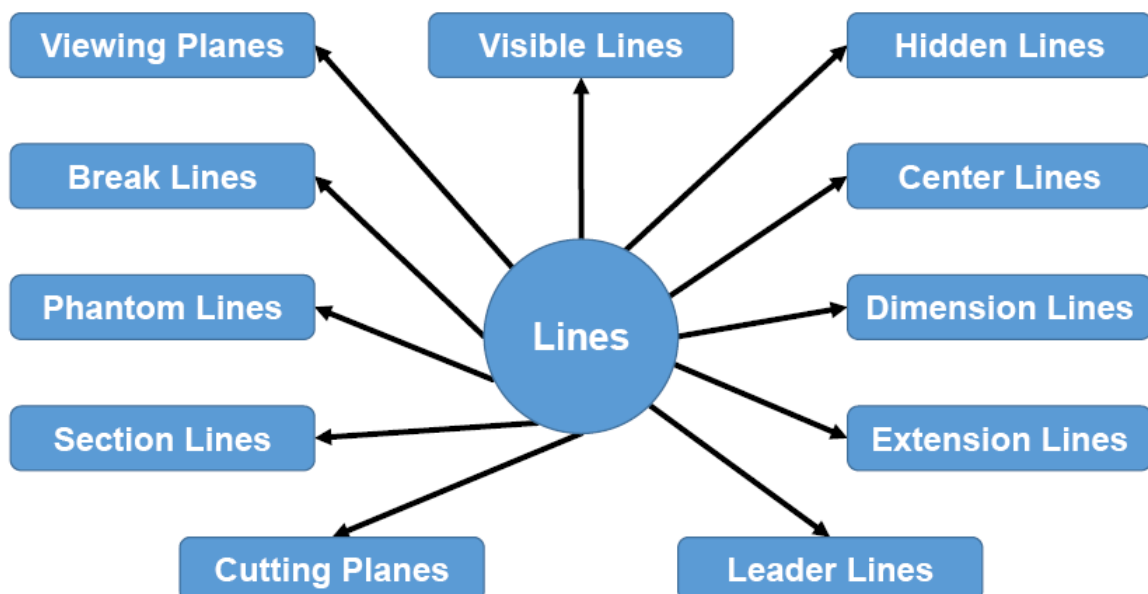

Visible/Object Lines

- Dark, heavy lines.
- Used to represent the outline or contour of the object being drawn.
- Define features you can see in a particular view.

THICK

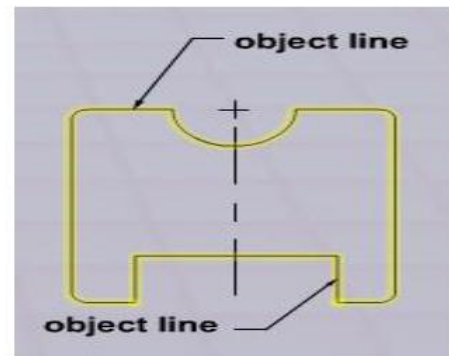
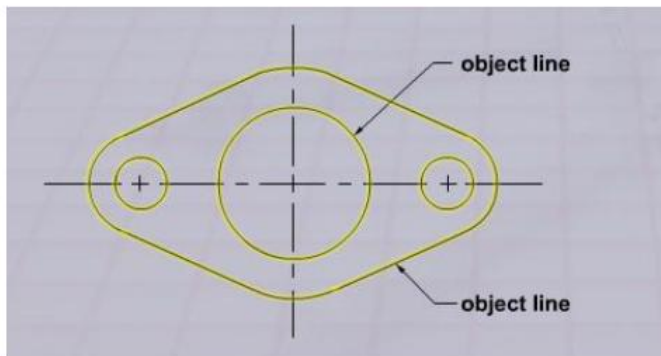

Hidden Lines

- Light, narrow, short, dashed lines.
- Shows the outline of a feature that cannot be seen in a particular view.
- Used to help clarify a feature, but can be omitted if they clutter a drawing.
- Hidden lines should always begin and end with a dash. Exception: When the hidden line begins or ends at a parallel visible or hidden line.
- Dashes should join at corners.

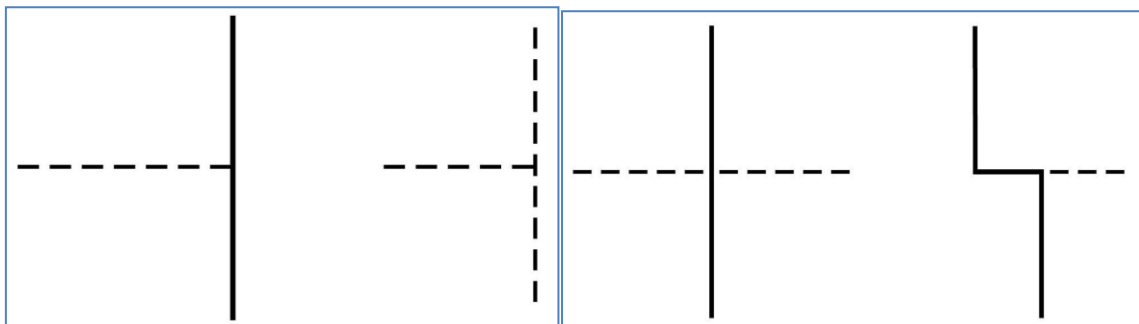
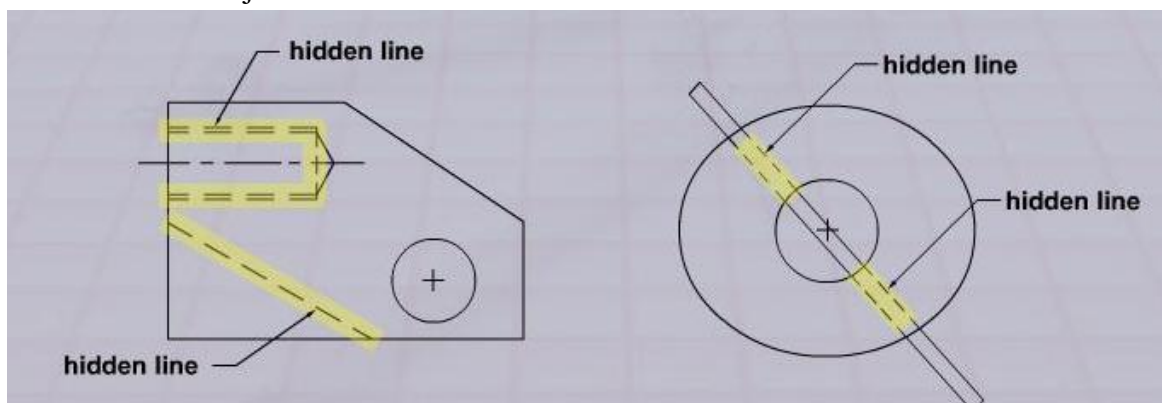

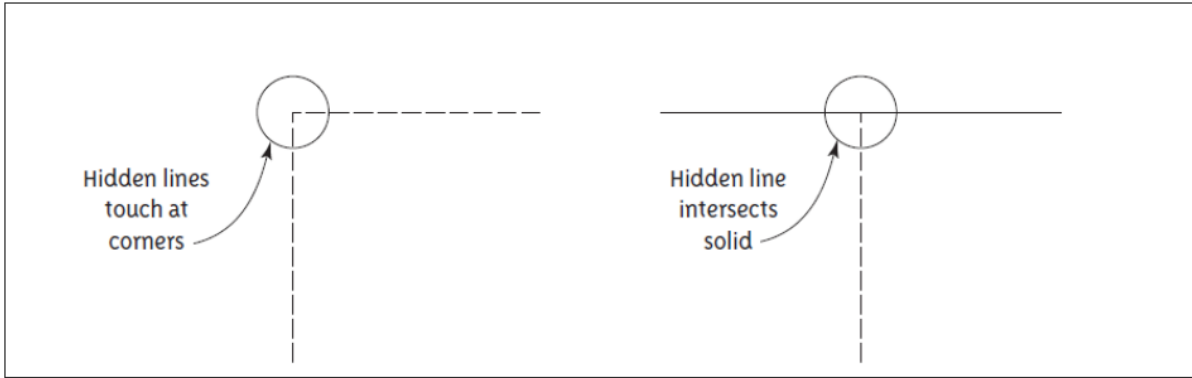

Section Lines

- Thin line usually drawn at a 45 degree angle.
- Indicates the material that has been cut through in a sectional view.

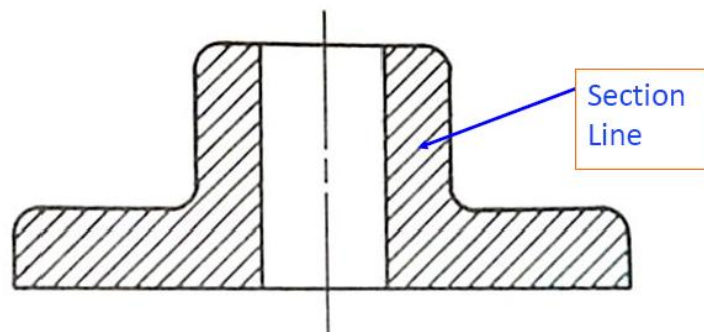

Center Lines

- Thin line consisting of alternating long and short dashes.
- Used to represent the center of round or cylindrical features, or the symmetry of a feature.
- Center lines should start and end with long dashes.

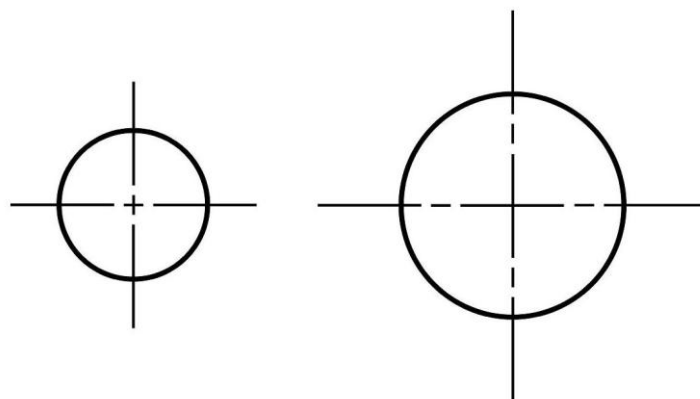

- Center lines should intersect by crossing either the long dashes or the short dashes.
- Center lines should extend a short distance beyond the object or feature.

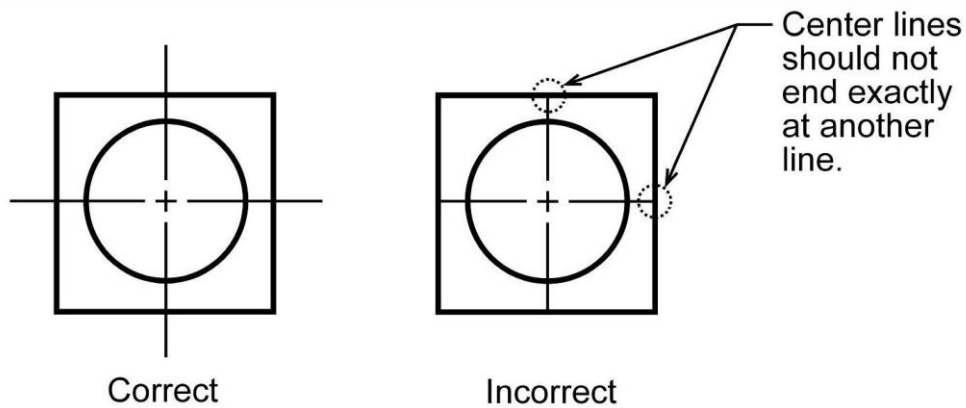

- Center lines may be connected **within a single view** to show that two or more features lie in the same plane. Center lines should not extend through the space between views.

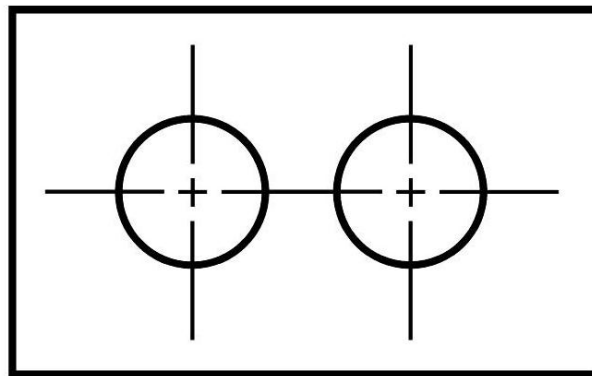

Dimension Lines

- Thin lines capped on the ends with arrowheads and broken along their length to provide a space for the dimension numeral.
- They indicate length.

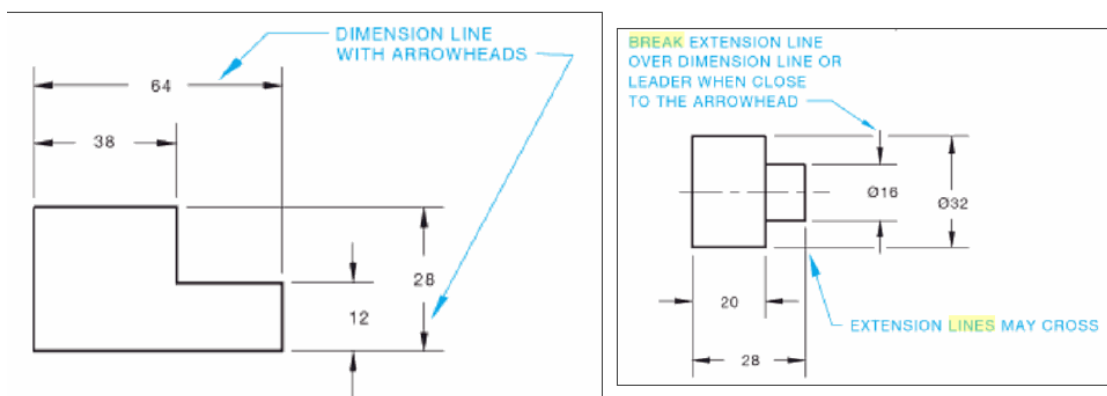

Extension Lines

Thin lines used to establish the extent of a dimension. Can also be used to show extension of a surface to a theoretical intersection as shown in (b). Begin 1.5mm from the object and extend to 3mm beyond the last dimension. They should not cross dimension lines.

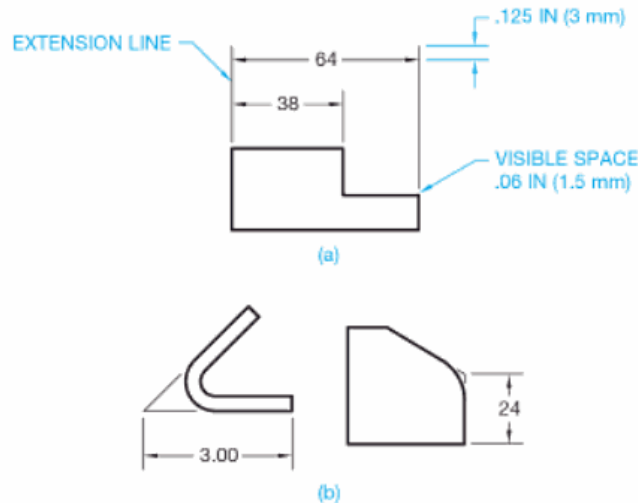

Leader Lines

- Thin lines used to connect a specific note to a feature.
- Also used to direct dimensions, symbols, item number and part numbers on a drawing.
- Commonly drawn at **45, 30 and 60** degrees.
- Has a **short shoulder** (3-6mm) at one end beginning at the center of the vertical height of text, and a **standard dimension arrowhead** at the other end touching the feature.
- Leader lines should not cross each other.
- Leader lines should not be excessively long.
- Leader lines should not be vertical or horizontal.
- Leader lines should not be parallel to dimension lines, extension lines or section lines.

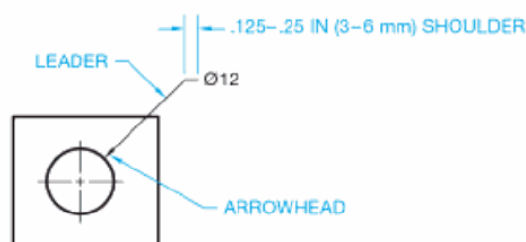

Arrowheads

- Used to terminate dimension lines and leader lines and on cutting-plane lines and viewing plane lines.
- They should be three times as long as they are wide.
- They should be the same size throughout the drawing.
- The filled arrowhead is generally preferred because of its clarity.

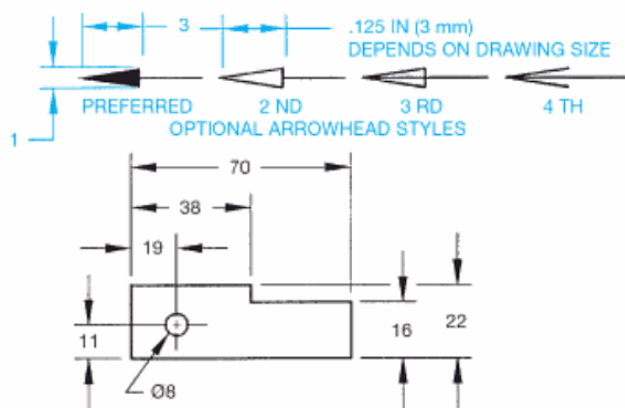

Cutting Plane Lines

- Thick broken line that is terminated with short **90 degree arrowheads**.
- Shows where a part is mentally cut in half to better see the interior detail.

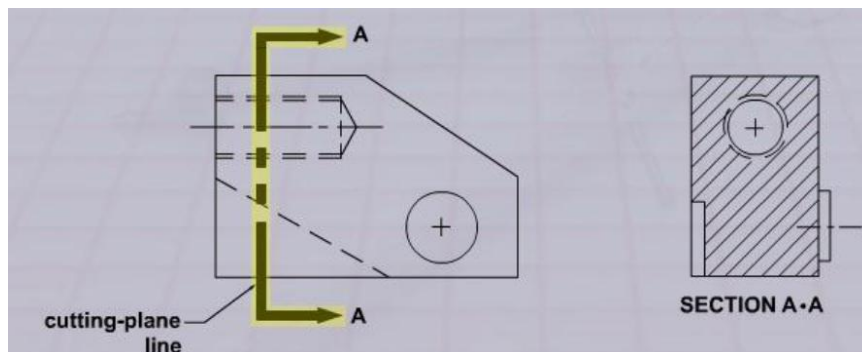
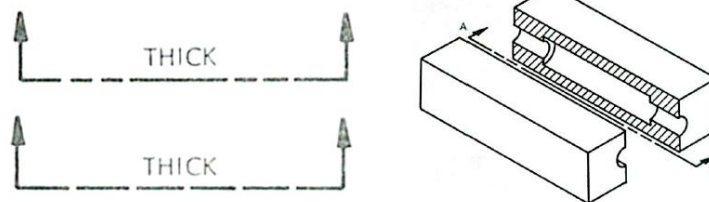

Break Lines

Break Lines are used to break out sections for clarity or for shortening a part. Three types of break lines with different line weights:

a) Short Break Lines.

- Thick wavy line.
- Used to break the edge or surface of a part for clarity of a hidden surface.

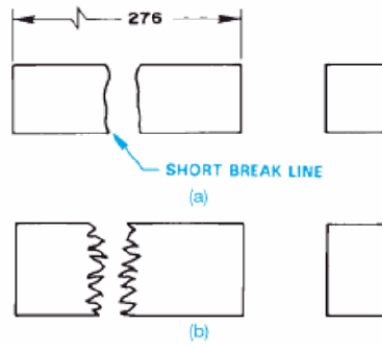

(a) Short break line on metal shape;
 (b) Short Break Line on wood shape.

b) Long Break Lines

- Long, thin lines.
- Used to show that the middle section of an object has been removed so it can be drawn on a smaller piece of paper.

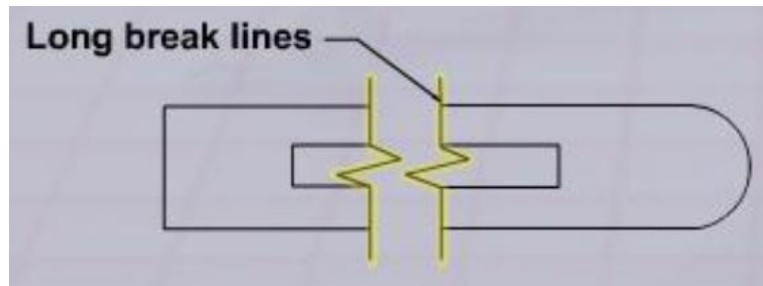

c) Cylindrical Break Lines.

- Thin lines.
- Used to show round parts that are broken in half to better clarify the print or to reduce the length of the object.

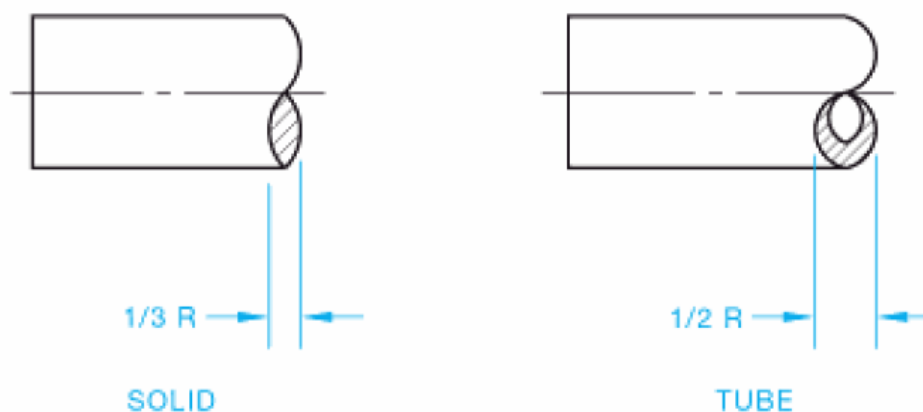

Cylindrical conventional breaks for a solid and tube;
 where $R = \text{Radius}$

Phantom Lines

- Thin lines made up of long dashes alternating with pairs of short dashes.
- Three purposes in drawings:
 - To show the alternate position of moving parts.
 - To show the relationship of parts that fit together.
 - To show repeated detail.

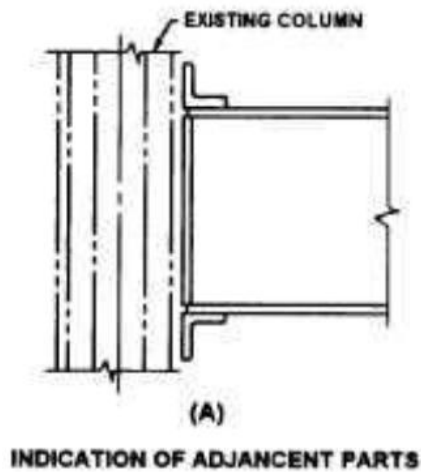
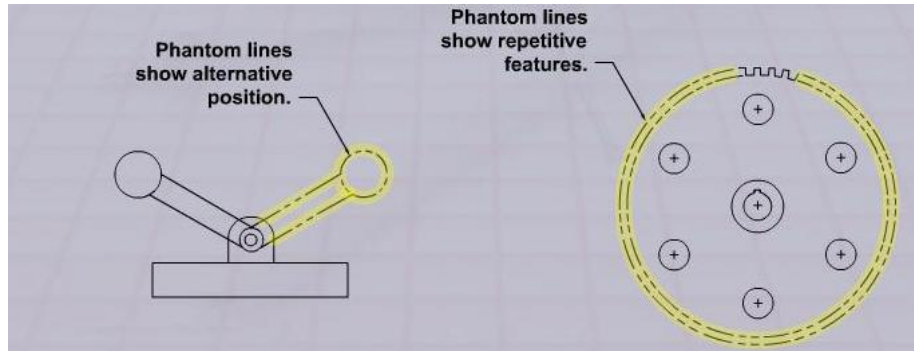

INDICATION OF ADJACENT PARTS

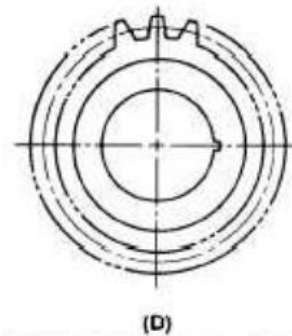
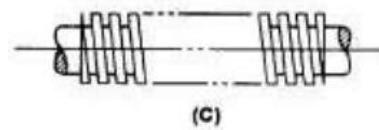
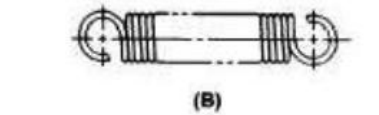

INDICATION OF REPEATED DETAIL

Line Precedence

If two lines occur in the same place, the line that is considered to be the least important is omitted. Lines in order of precedence/importance are as follows:

- Cutting plane line
- Visible line
- Hidden line
- Centerline

Example

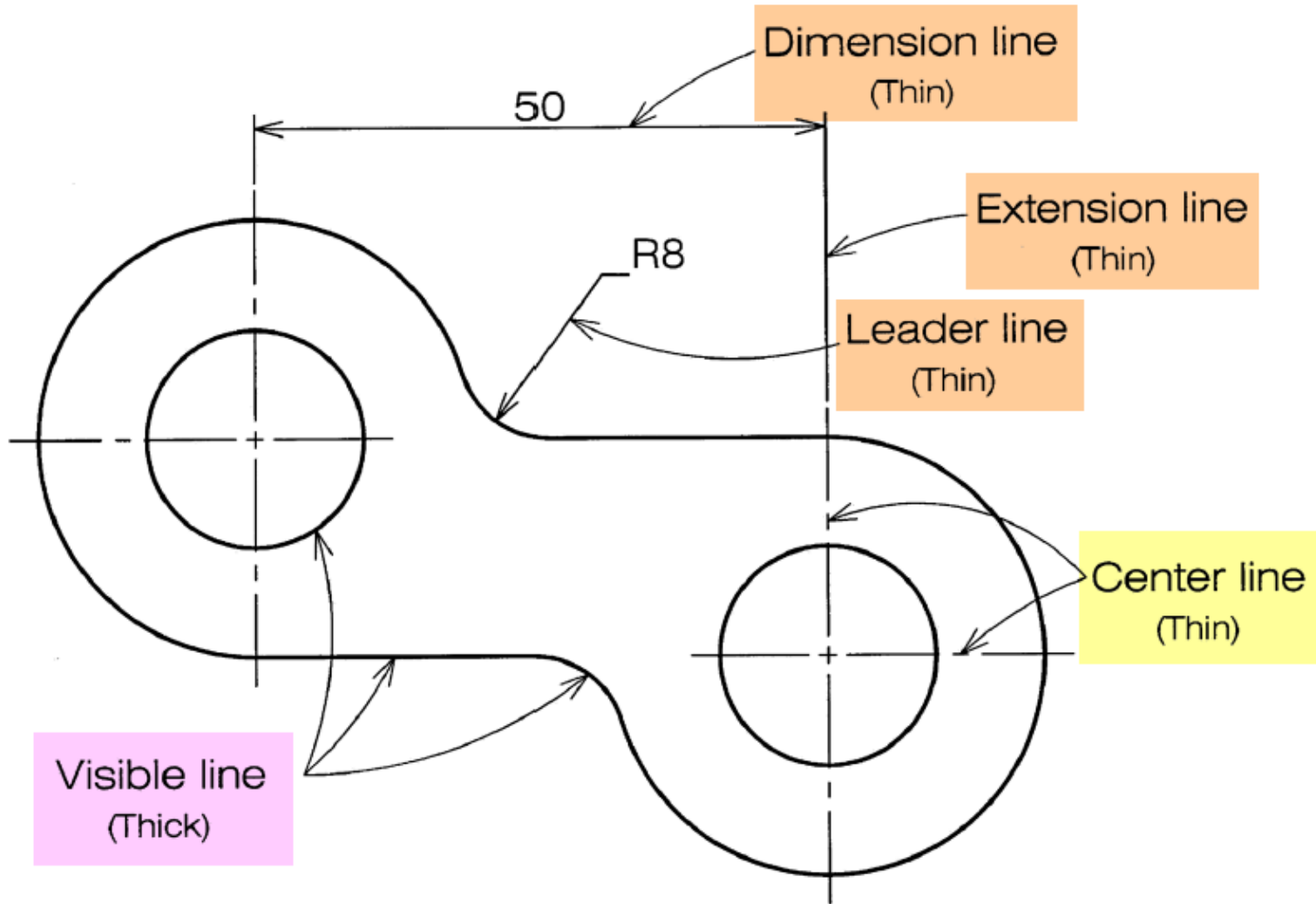

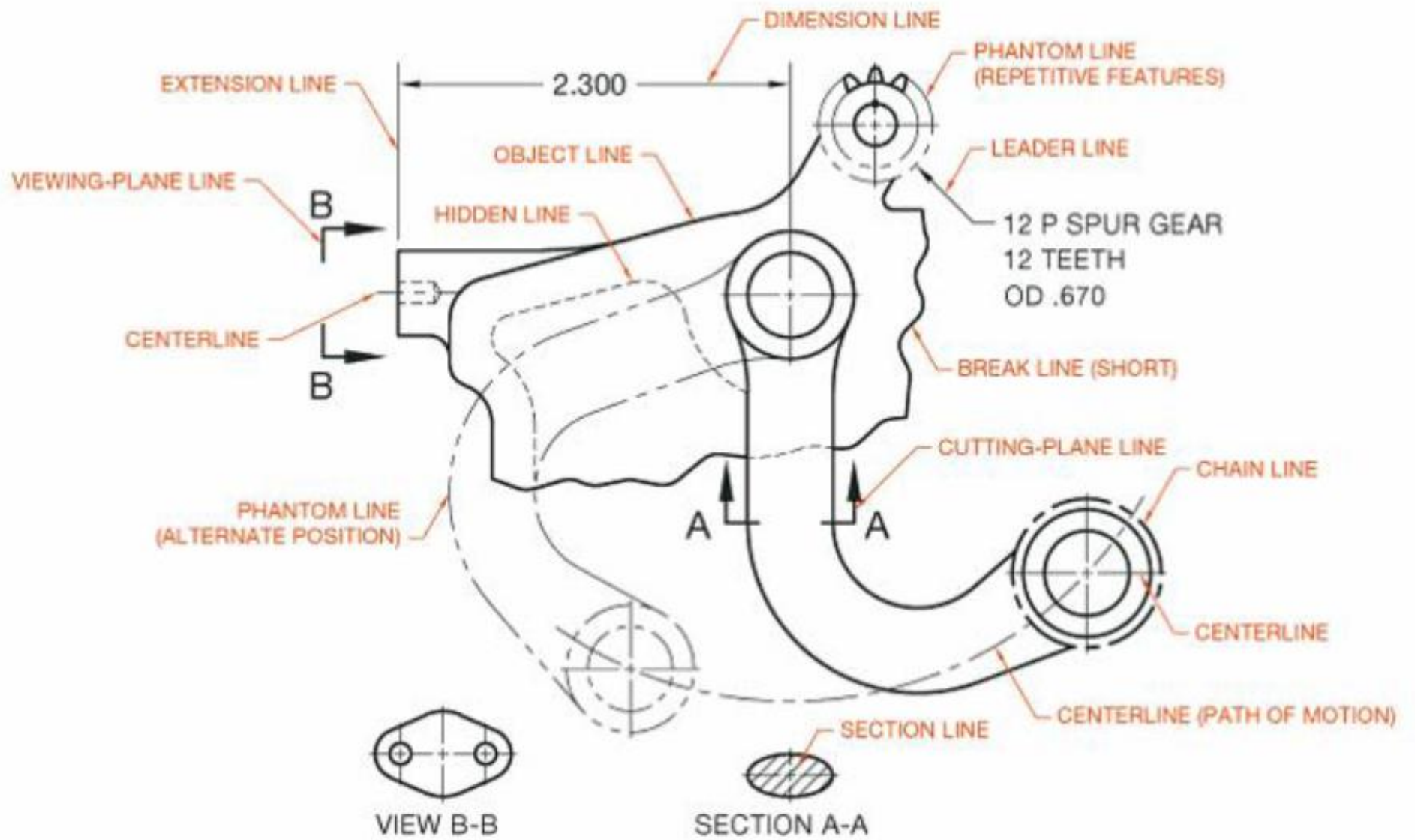

Topic 5

Perspective Projections

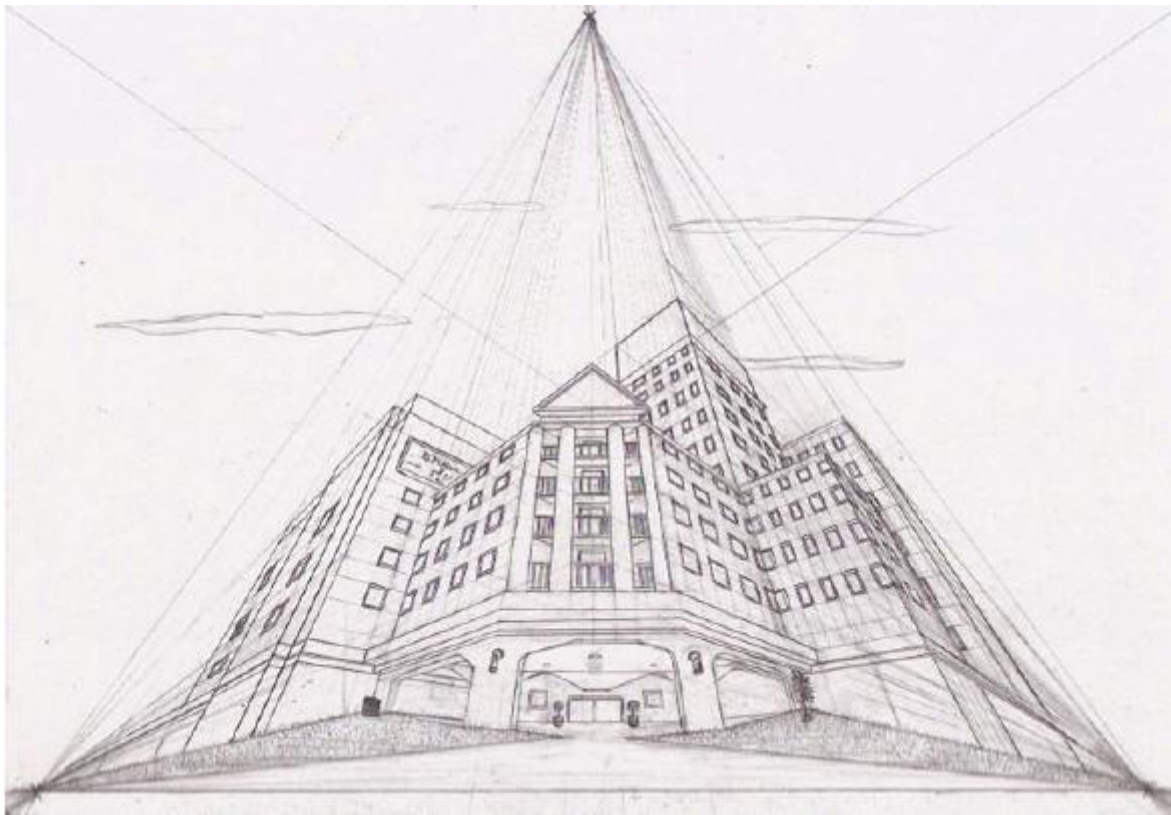

Projection

- Projections transform points from n (here, $n = 3$) dimensional space into a space of dimension less than n (here, $n = 2$)
- Points to be considered,
 - Location of object
 - Location of observer
 - Plane of projection
 - Projectors/lines of projection

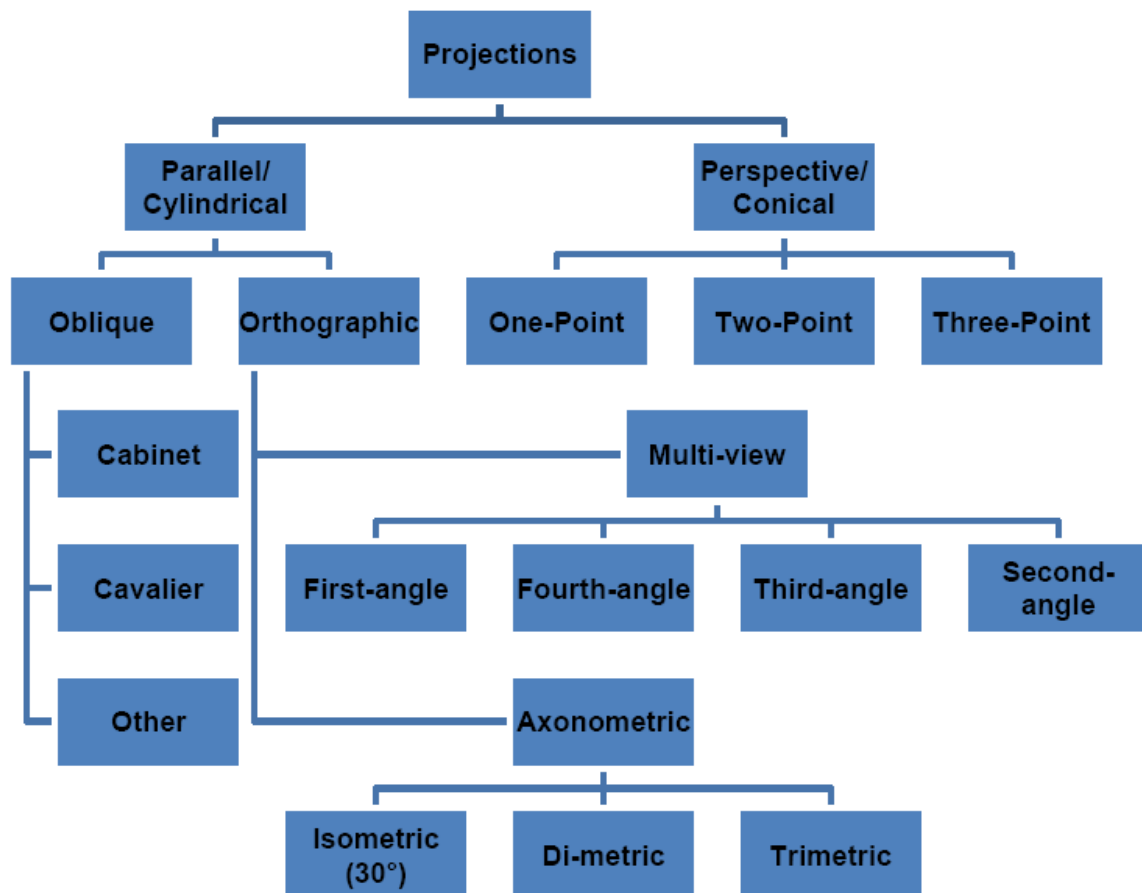

Parallel Projections

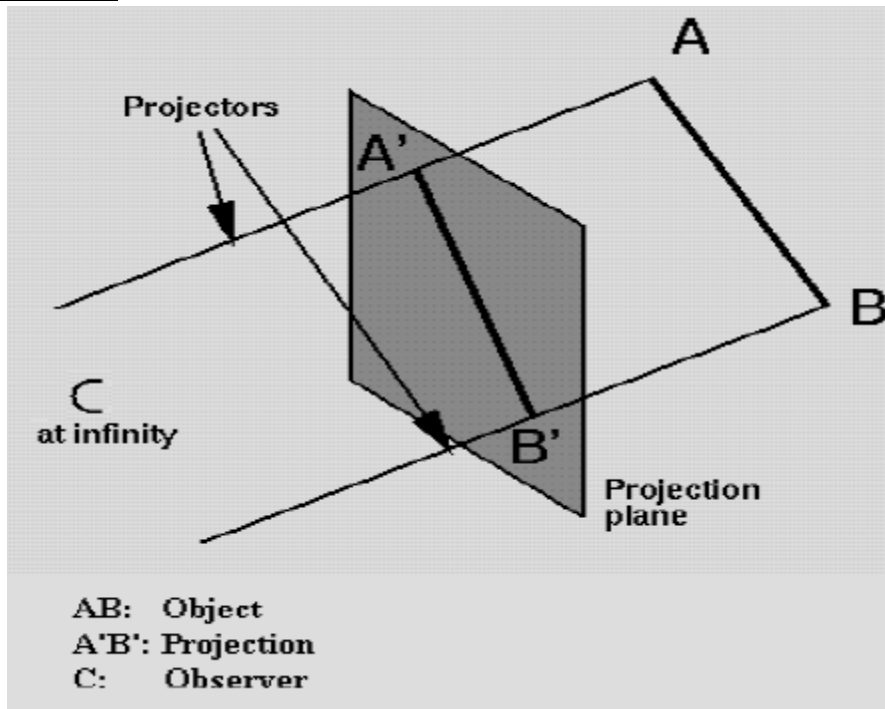

Parallel Projection is a type of projection where the line of sight or projectors are parallel and are perpendicular to the picture planes. It is subdivided into the following three categories: Orthographic, Oblique and Axonometric Projections.

- Orthographic projections: are drawn as multi view drawings, which show flat representations of principal views of the subject.
- Oblique Projections: actually show the full size of one view.
- Axonometric Projections: are three-dimensional drawings, and are of three different varieties:
Isometric, Dimetric and Trimetric.

Orthographic Projections

- Orthographic projections are drawings where the projectors, the observer or station point remain parallel to each other and perpendicular to the plane of projection.
- Orthographic projections are further subdivided into axonometric projections and multi-view projections.
- Effective in technical representation of objects.

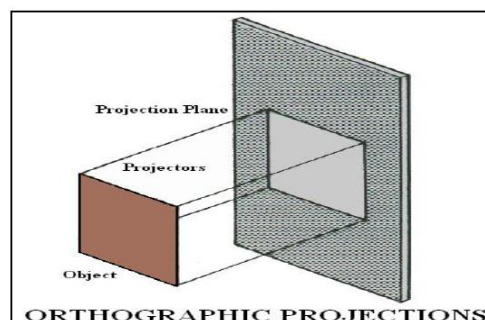

Oblique Projections

- *Projectors* are parallel to each other but not perpendicular to *projection plane*.
- An oblique projection shows front and top surfaces that include the three dimensions of height, width, and depth.
- The front or principal surface of an object (the surface toward the plane of projection) is parallel to the plane of projection.
- Effective in pictorially representing objects.

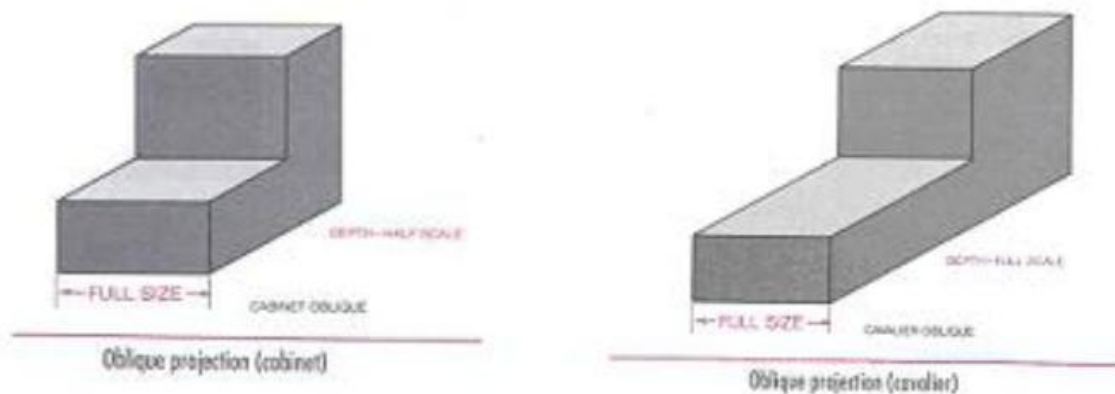
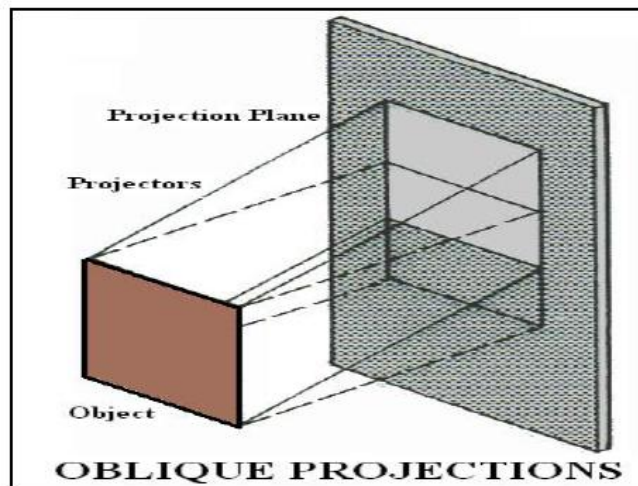
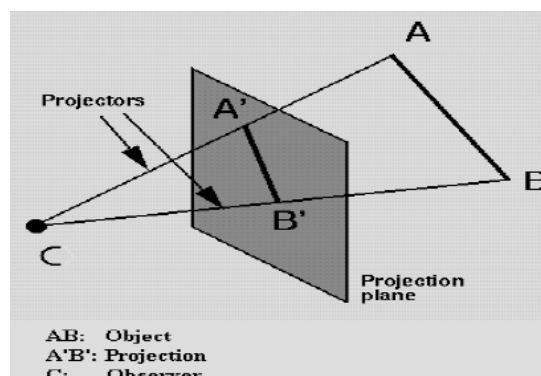

Figure: Oblique drawing

Perspective Projections



Perspective projections are drawings which attempt to replicate what the human eye actually sees when it views an object. There are three types of perspective projections: One-point, Two-point and Three-point Projections.

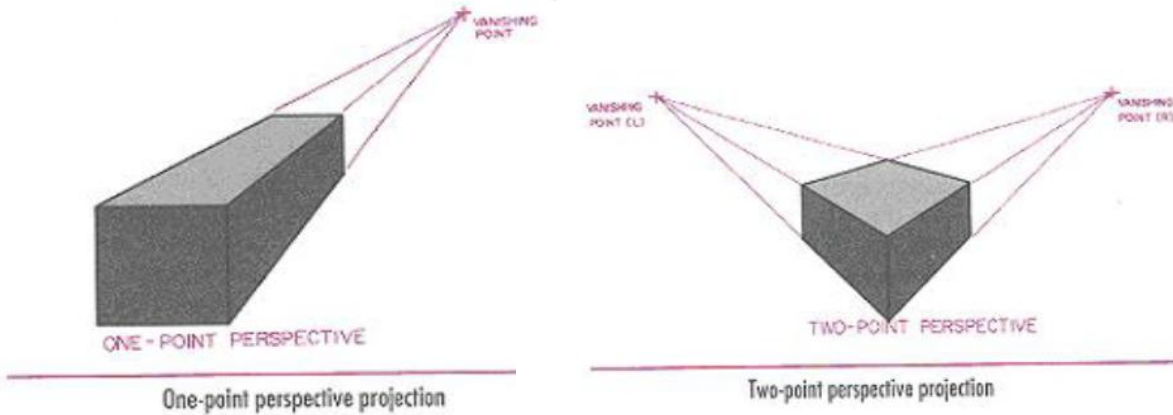
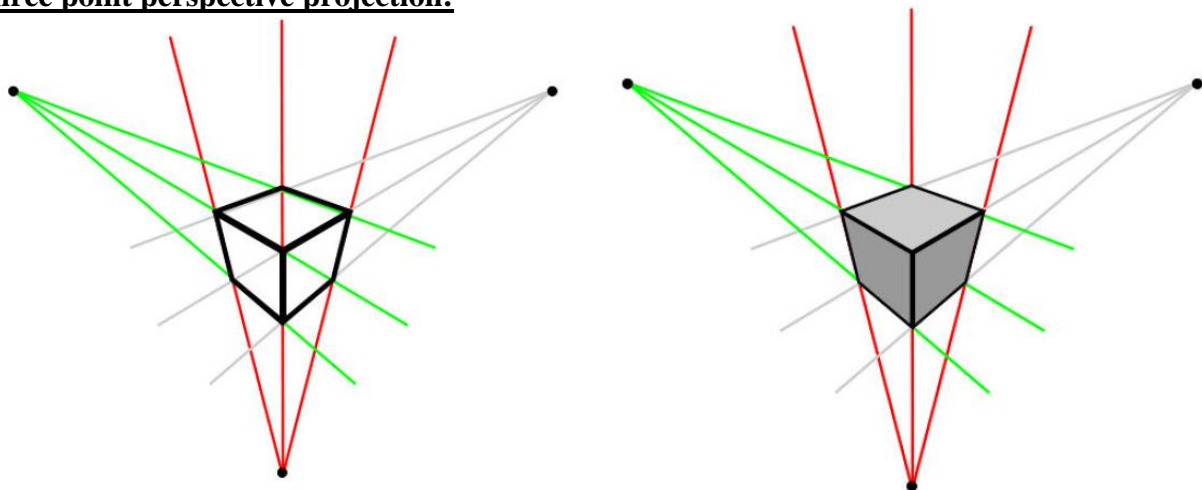

Figure: Perspective projection

Three point perspective projection:



Some real world examples of one 1 point, 2 point and 3 point Perspective projection:





Figure: One Point Perspective Projections

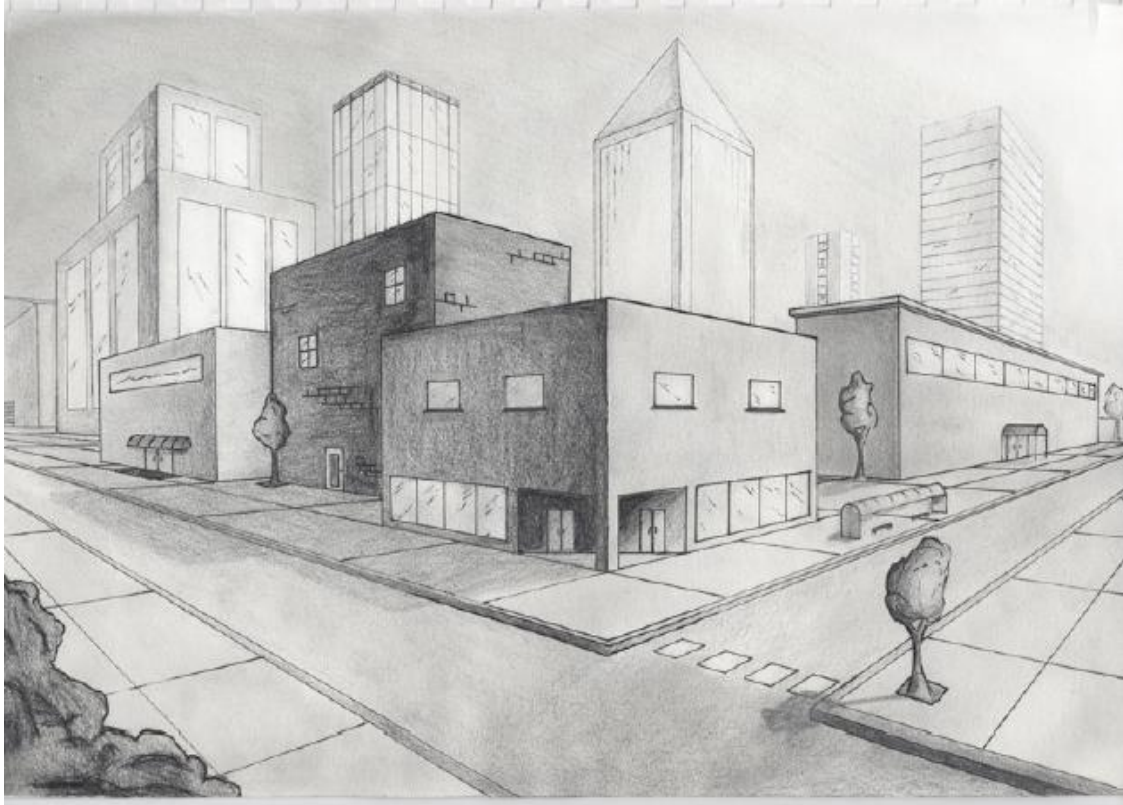

Figure: Two Point Perspective Projections

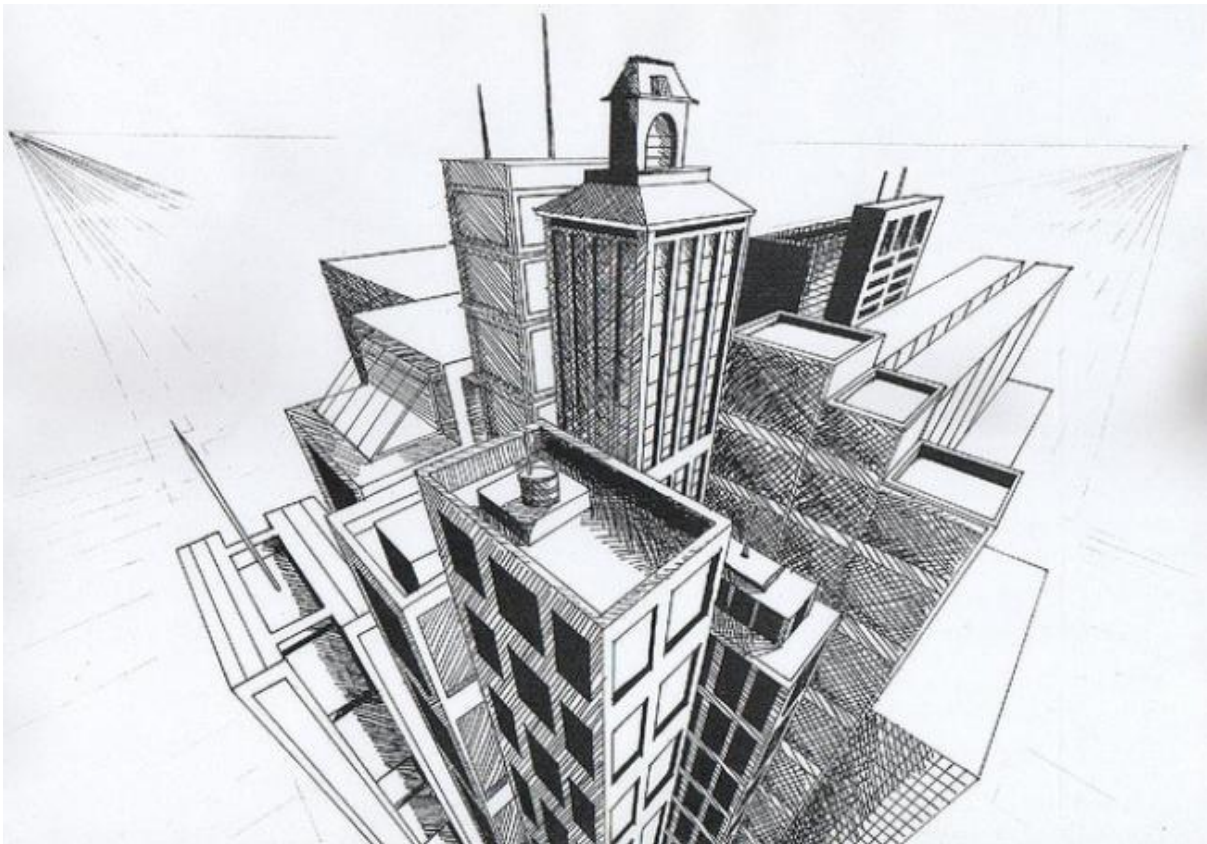
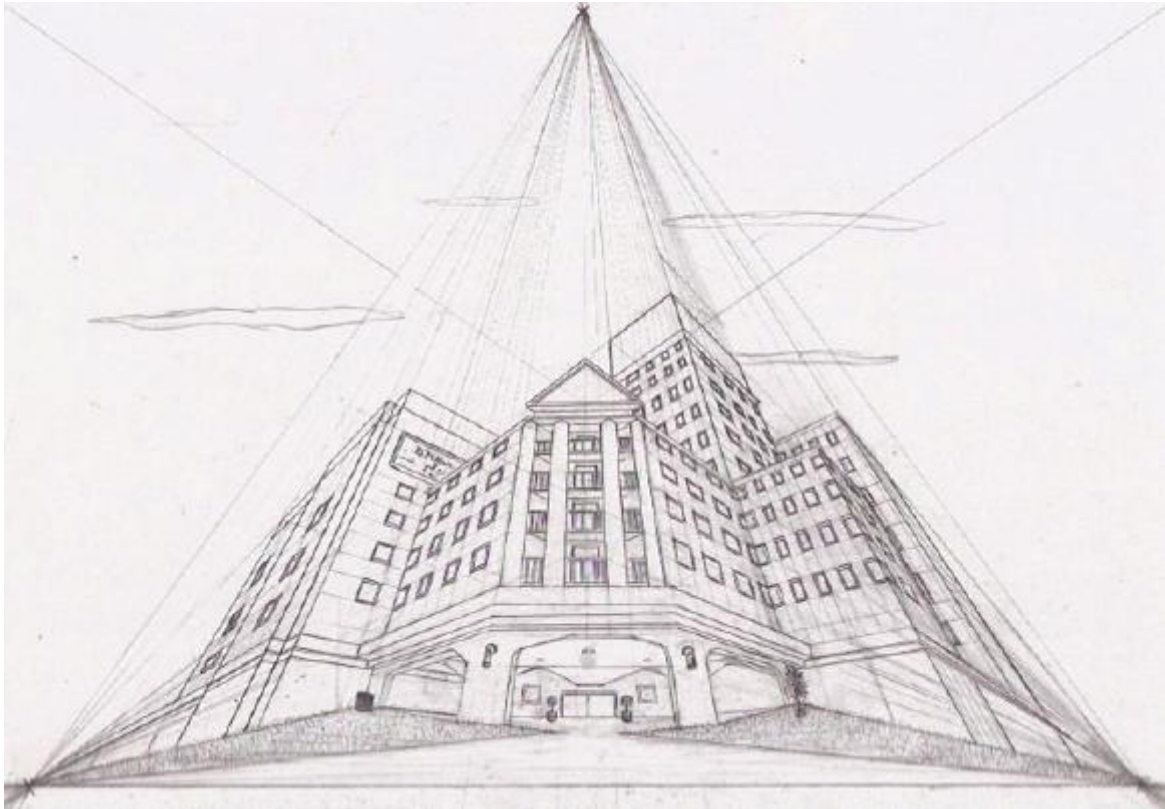
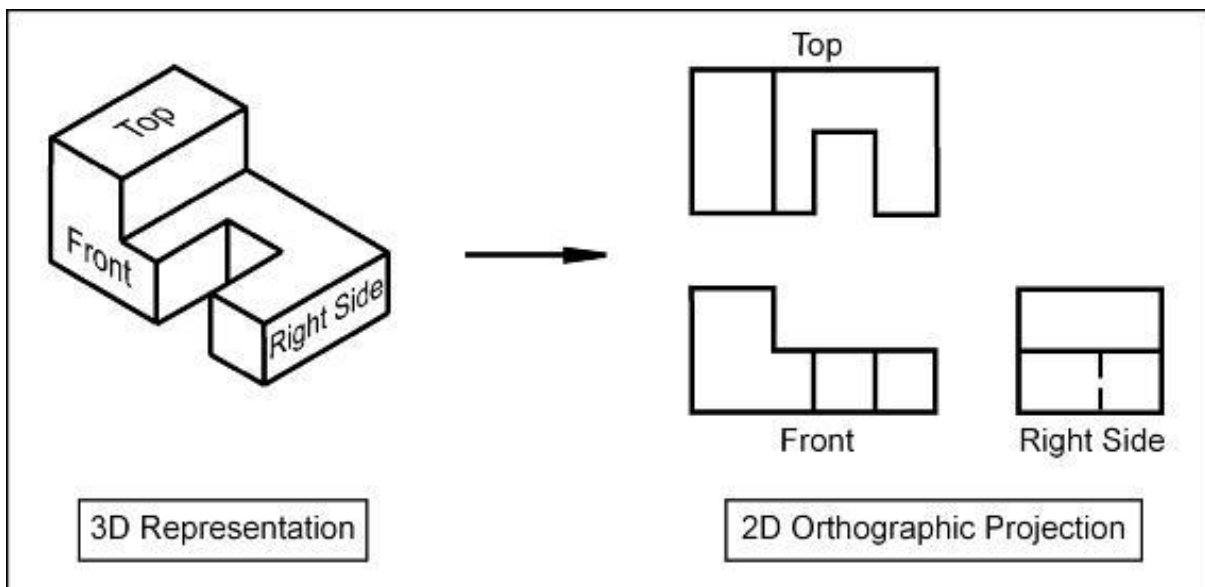



Figure: Three Point Perspective Projections

Topic 6

Orthographic Projections and Isometric Drawing



Introduction

Orthographic projection = 2-D representation of a 3-D object.

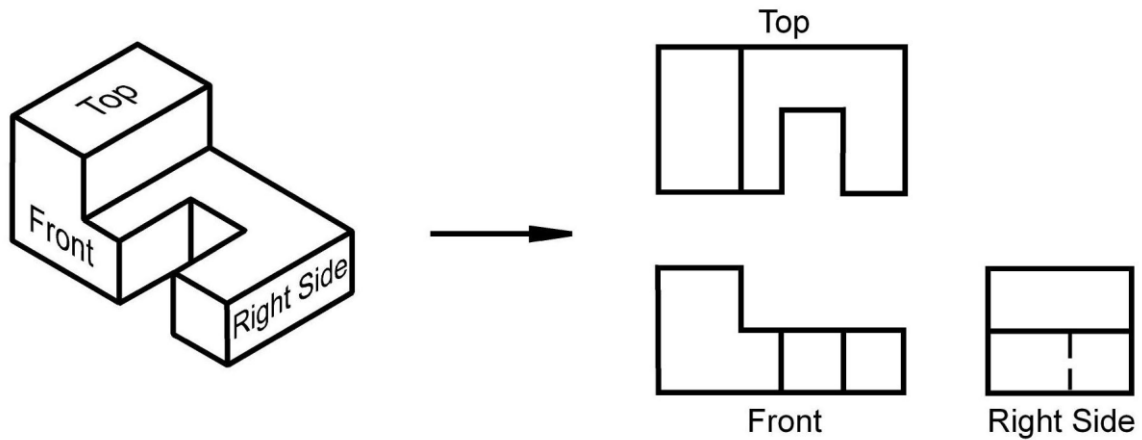

The Six Principal Views

The 6 principal views are created by looking at the object, straight on, in the directions indicated.

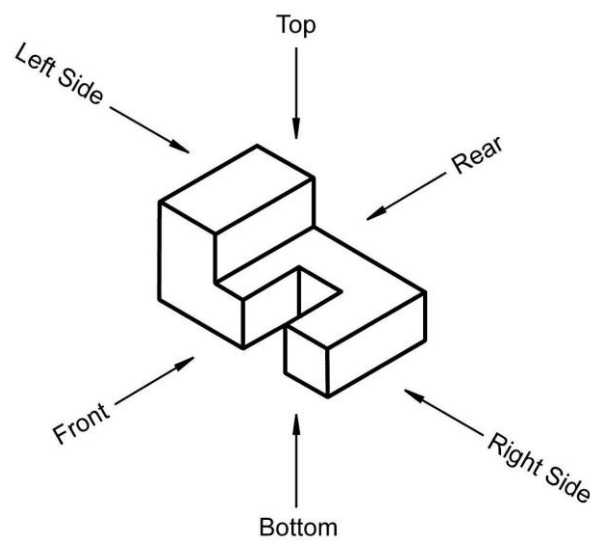

The Glass Box Method

- The object is placed in a glass box.
- The sides of the box represent the 6 principal planes.
- The image of the object is projected on the sides of the box.
- Things to notice:
 - The projection planes.
 - The projectors.
 - How surfaces A and B are projected.
- The box is unfolded creating the 6 principal views.

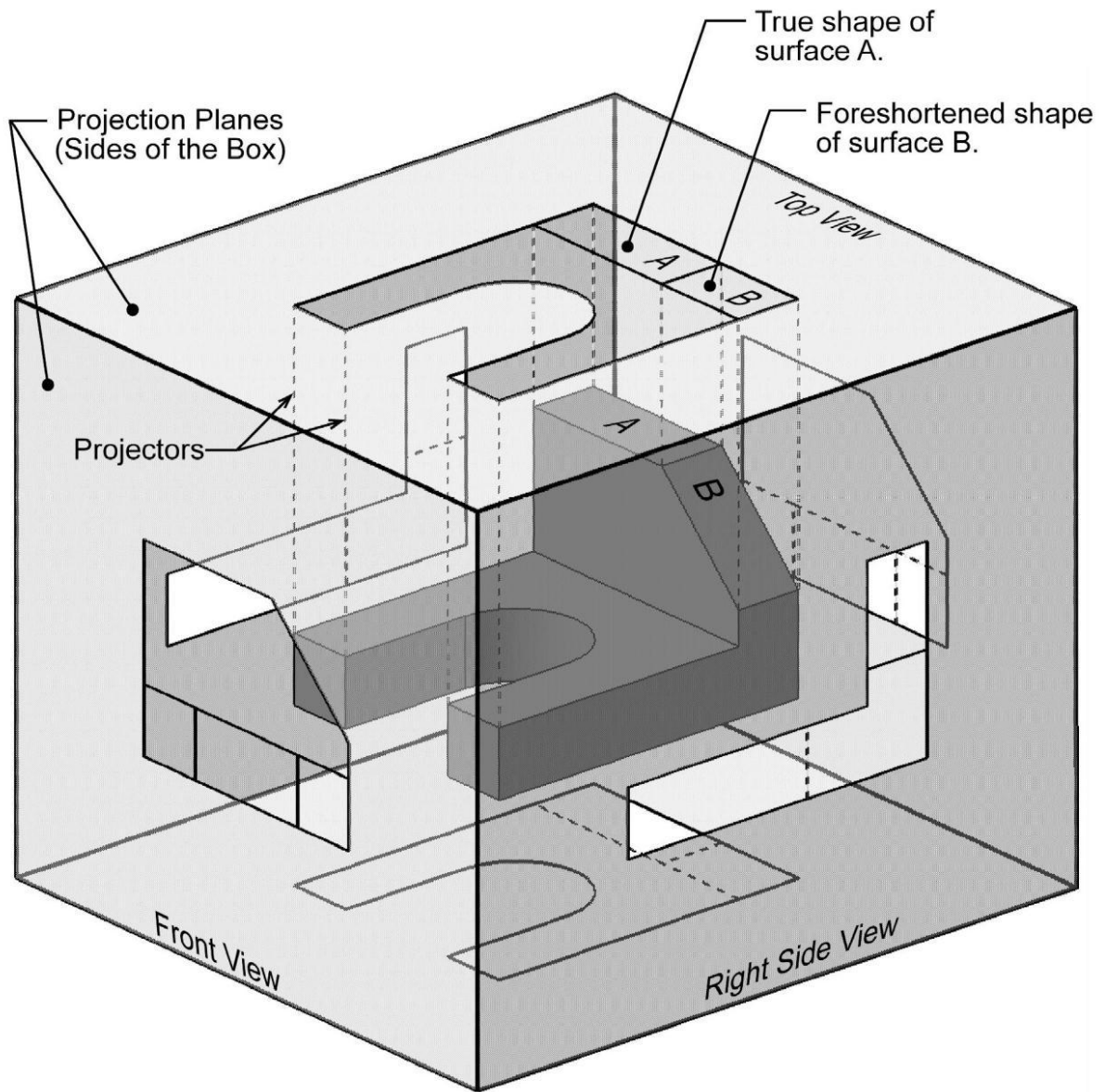
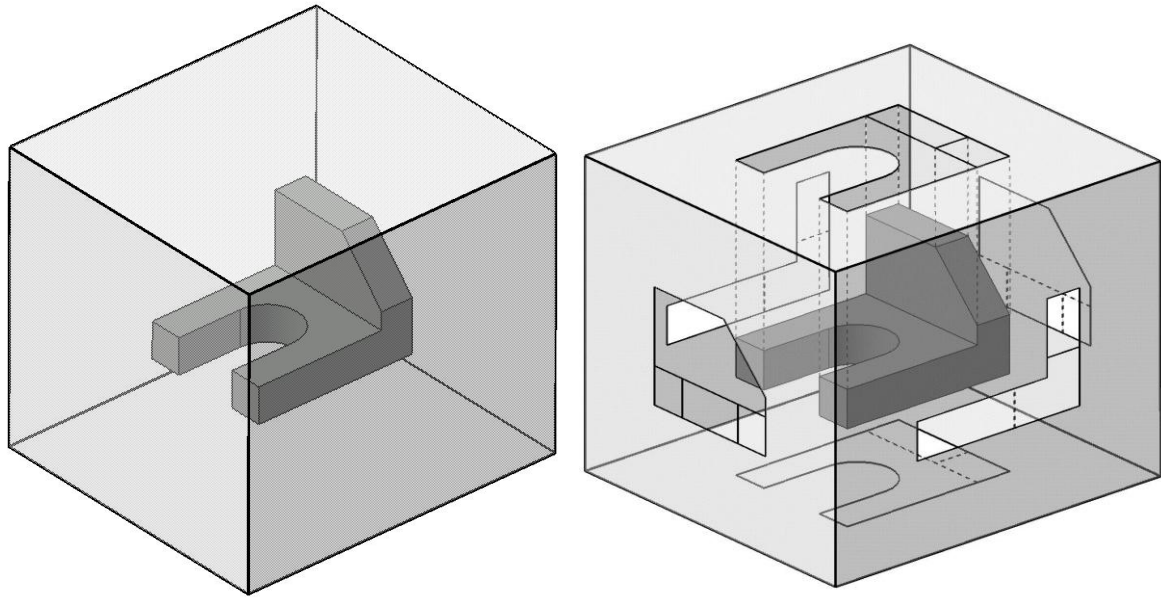

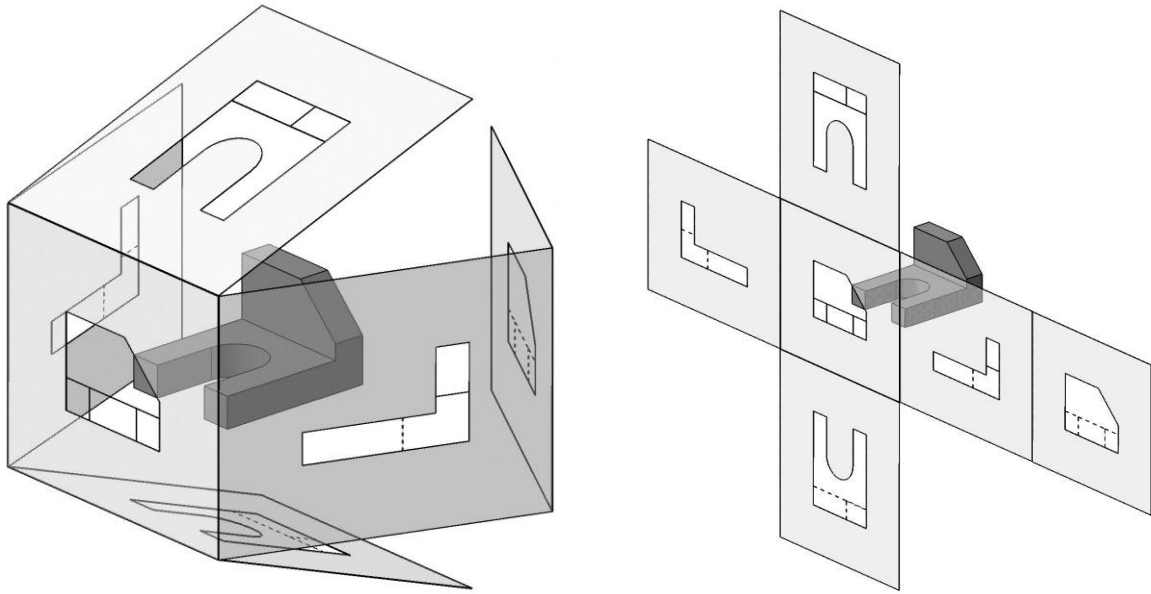

Standard Views

When constructing an orthographic projection, we need to include enough views to completely describe the true shape of the part.

- Complex part = more views
- Simple part = less views

Front View

The front view shows the most features or characteristics of the object.

- It usually contains the least amount of hidden lines.
- The front view is chosen first and the other views are based on the orientation of the front view.

View Alignment

- The top and front views are aligned vertically and share the same width dimension.
- The front and right side views are aligned horizontally and share the same height dimension.

1.

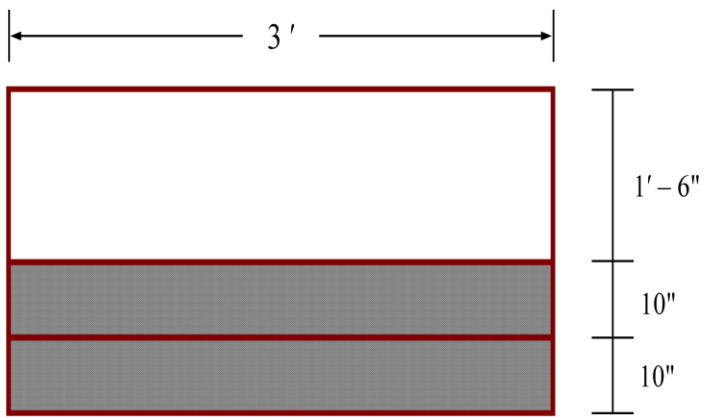
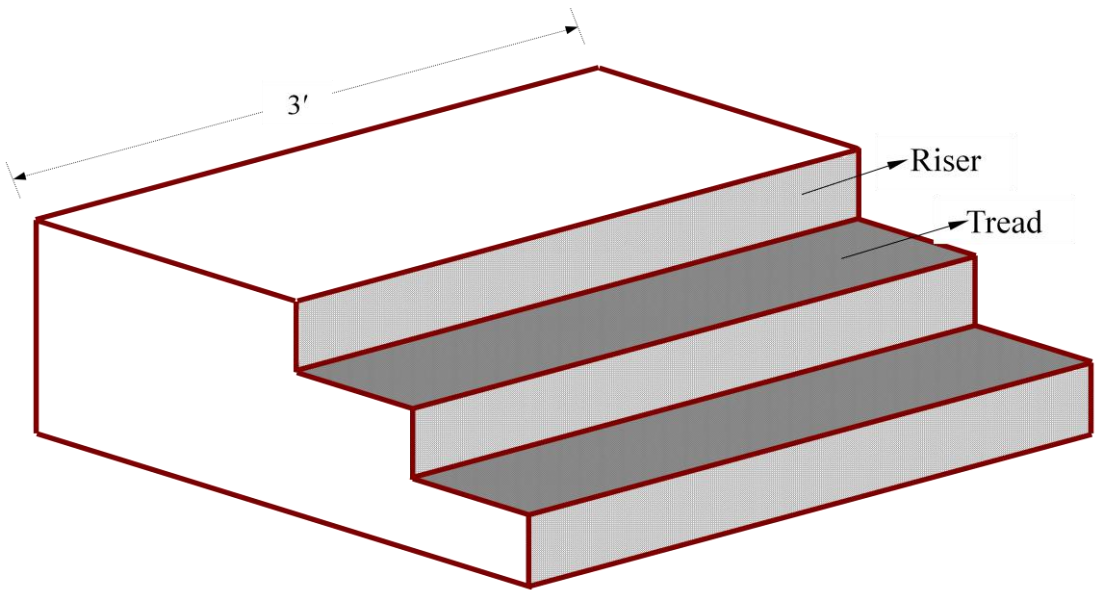

TOP VIEW

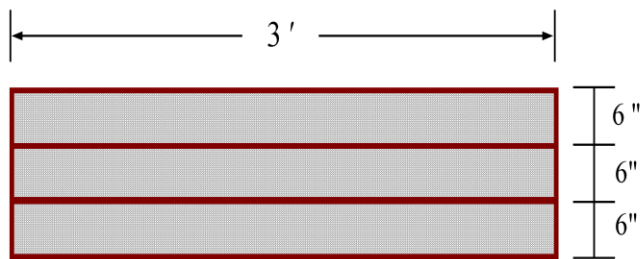

FRONT VIEW

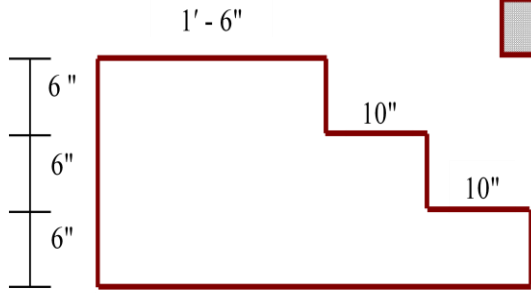

LEFT VIEW

2.

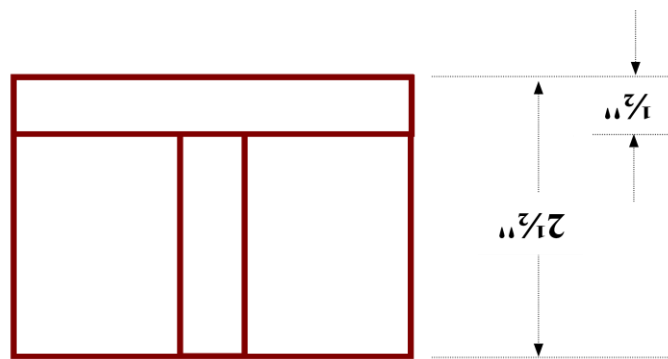
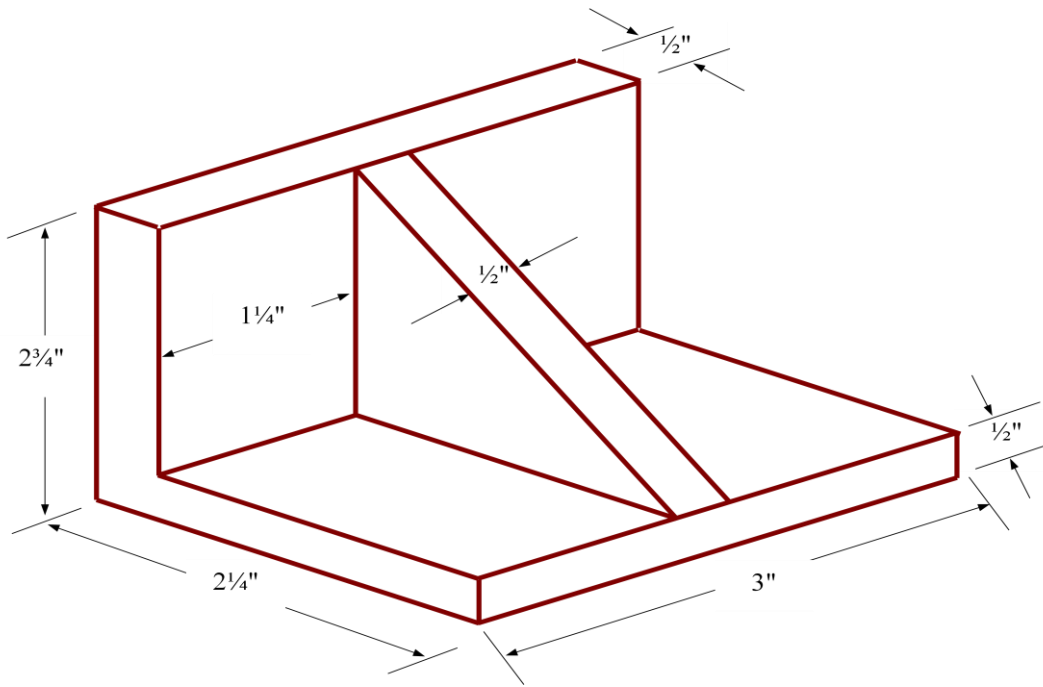

TOP VIEW

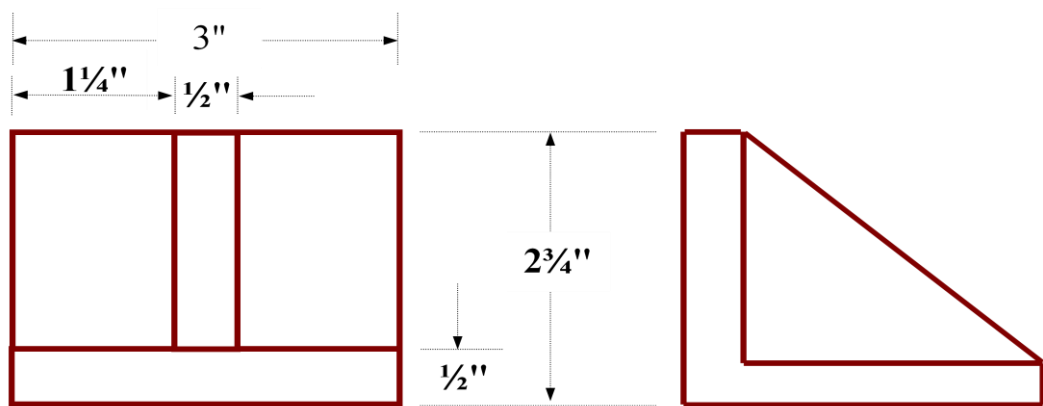

FRONT VIEW

LEFT VIEW

3.

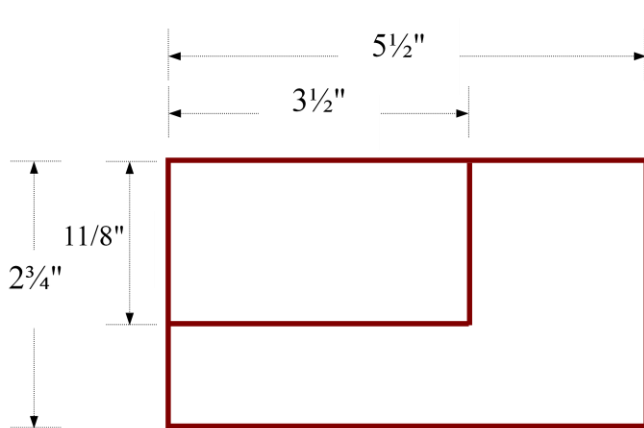
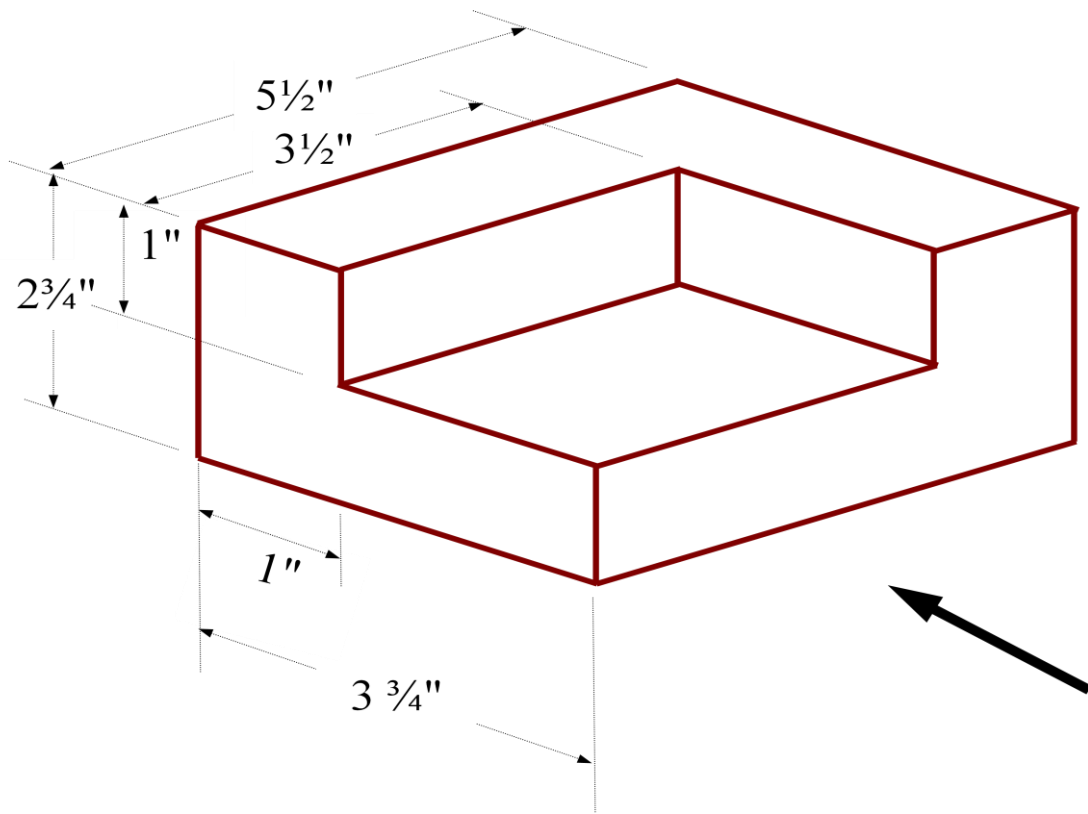

FRONT VIEW

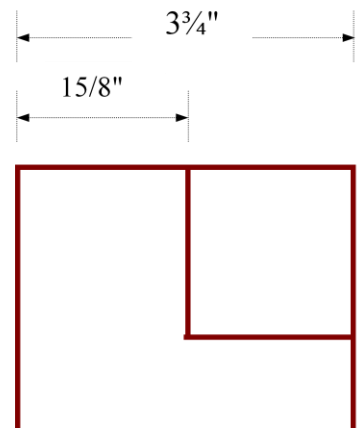

LEFT VIEW



TOP VIEW

4.

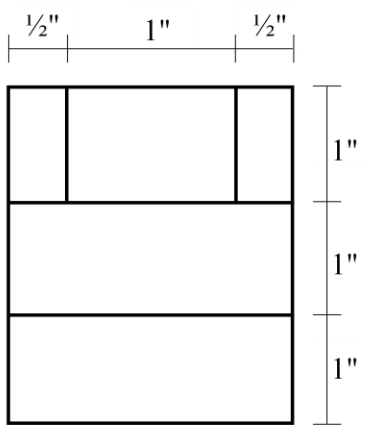
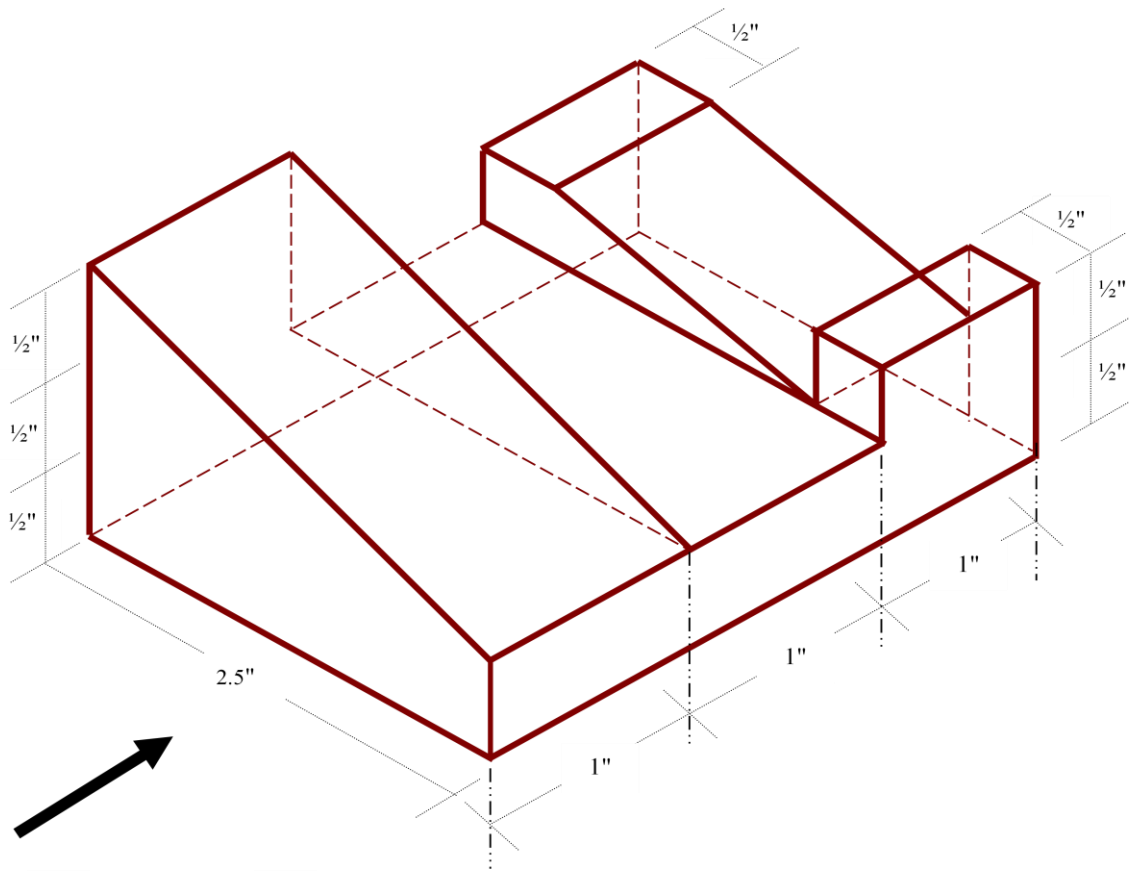

TOP VIEW

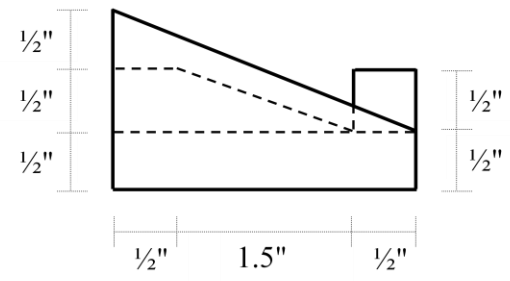

FRONT VIEW

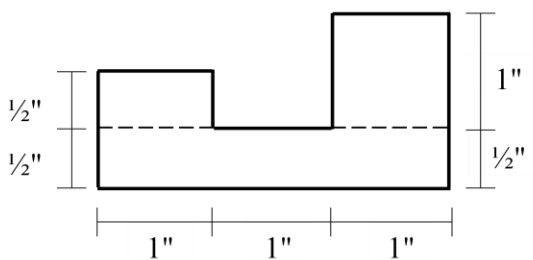

LEFT VIEW

5.

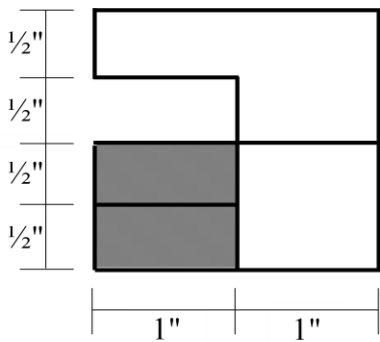
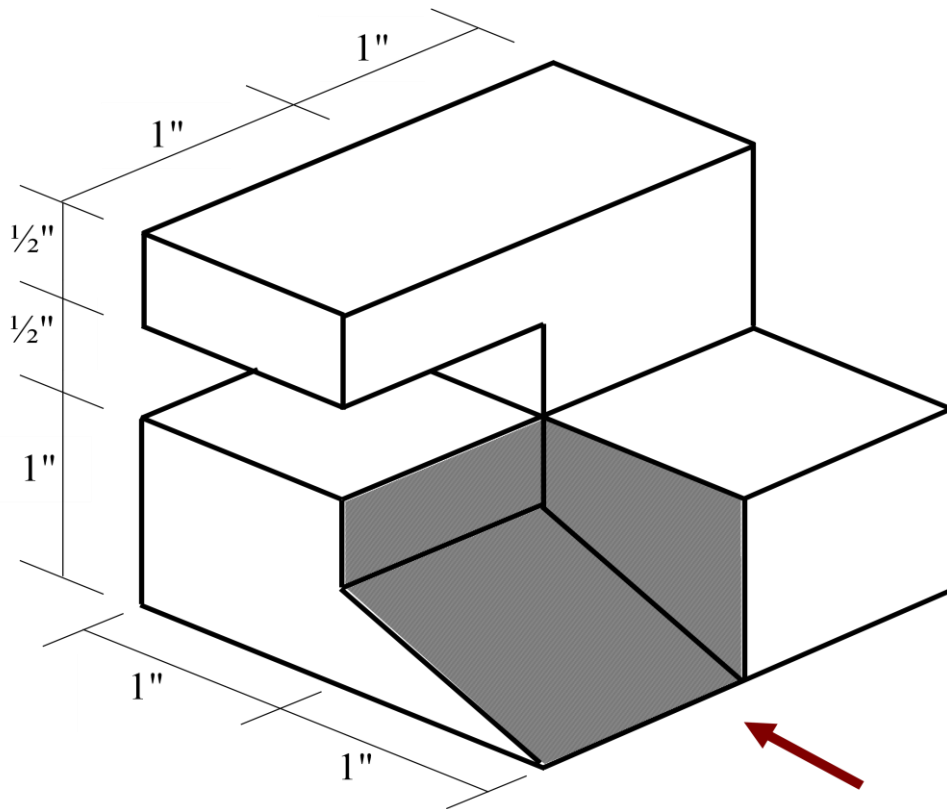

FRONT VIEW

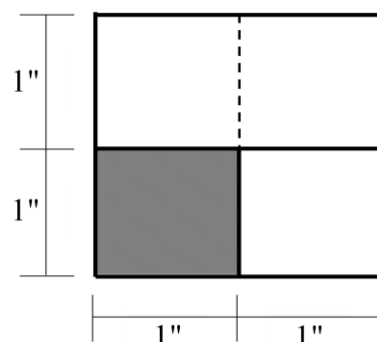

TOP VIEW

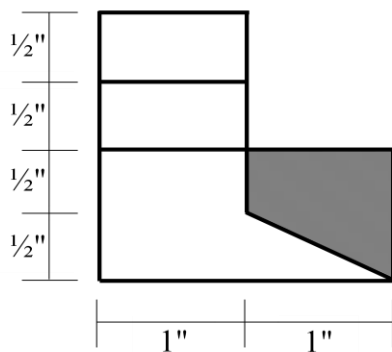

LEFT VIEW

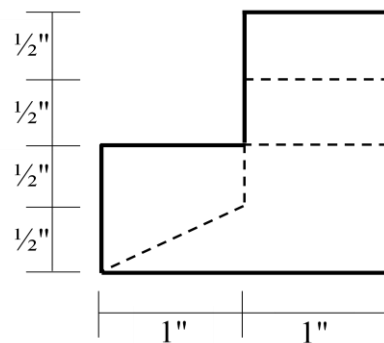

RIGHT VIEW

Orthographic to Isometric Drawing

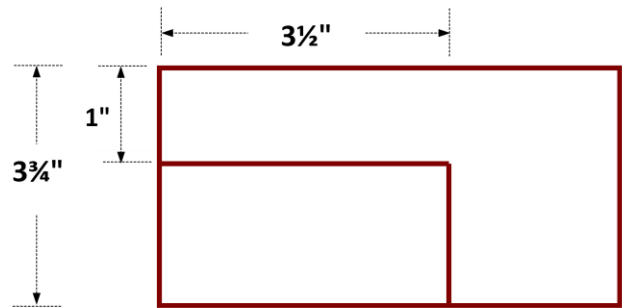
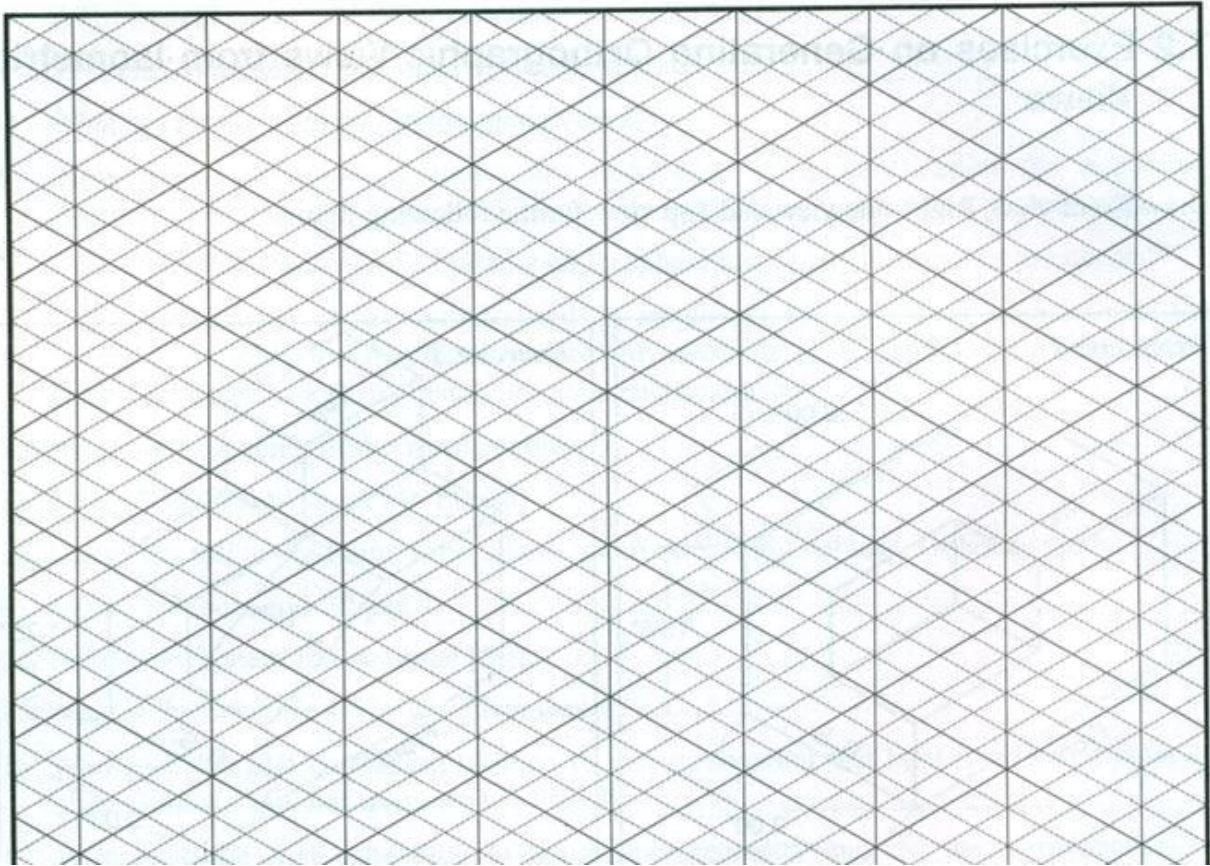

TOP VIEW

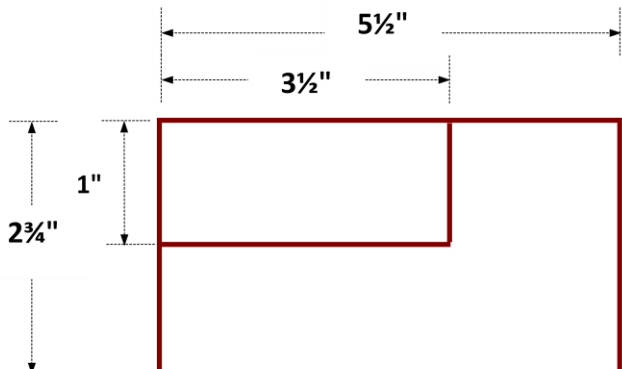
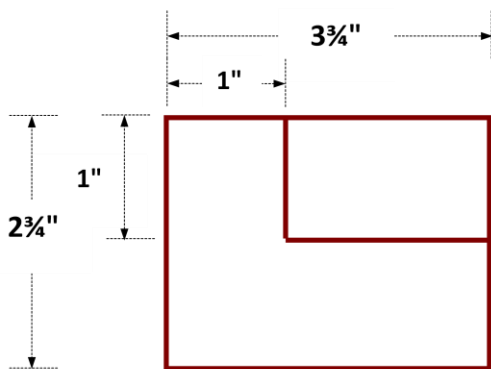

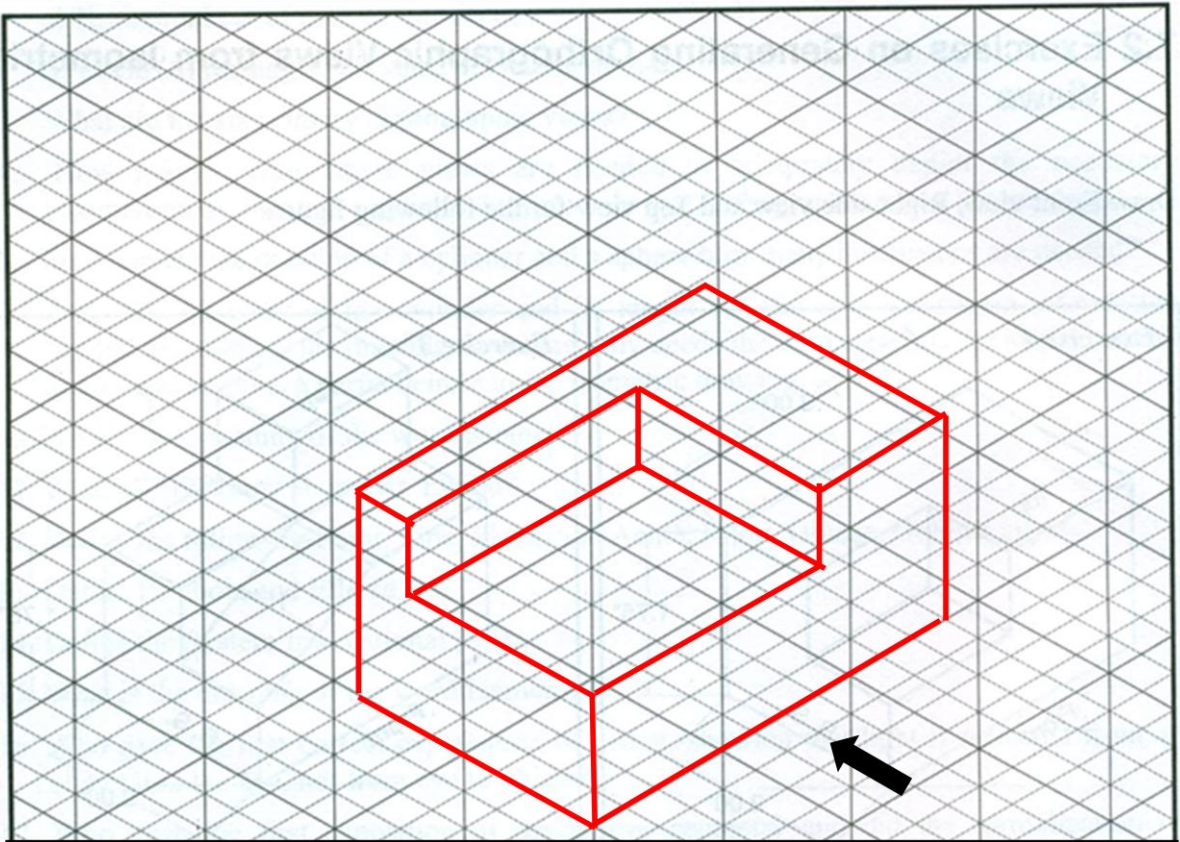
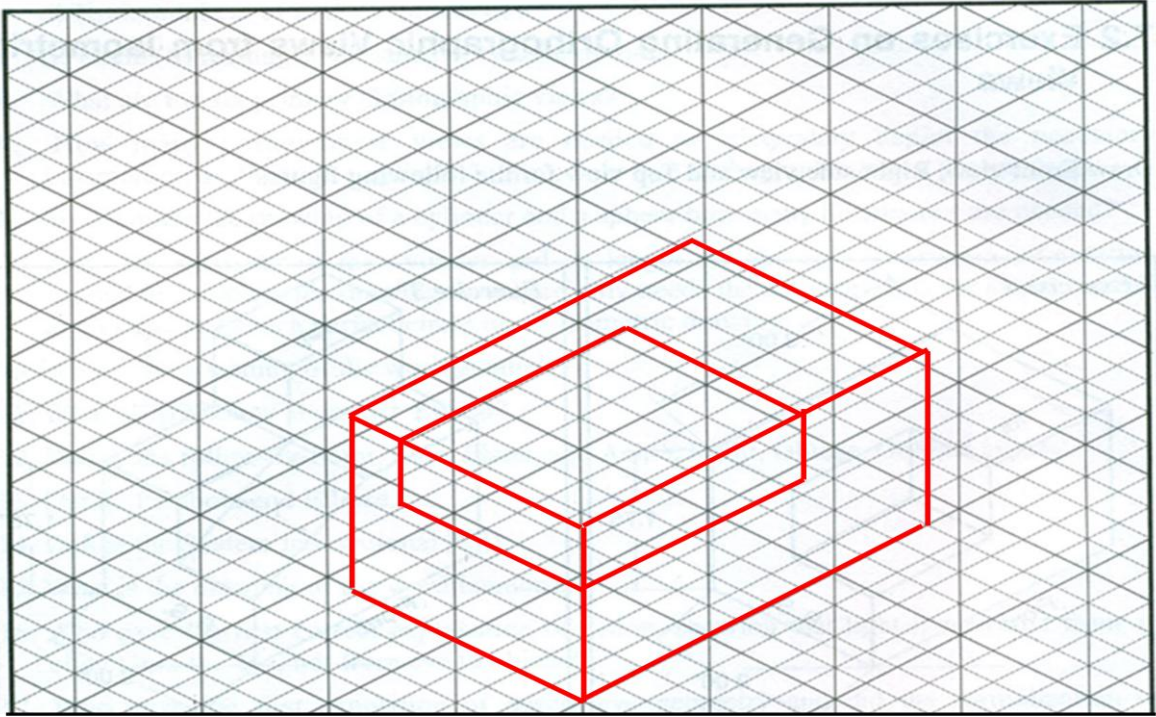

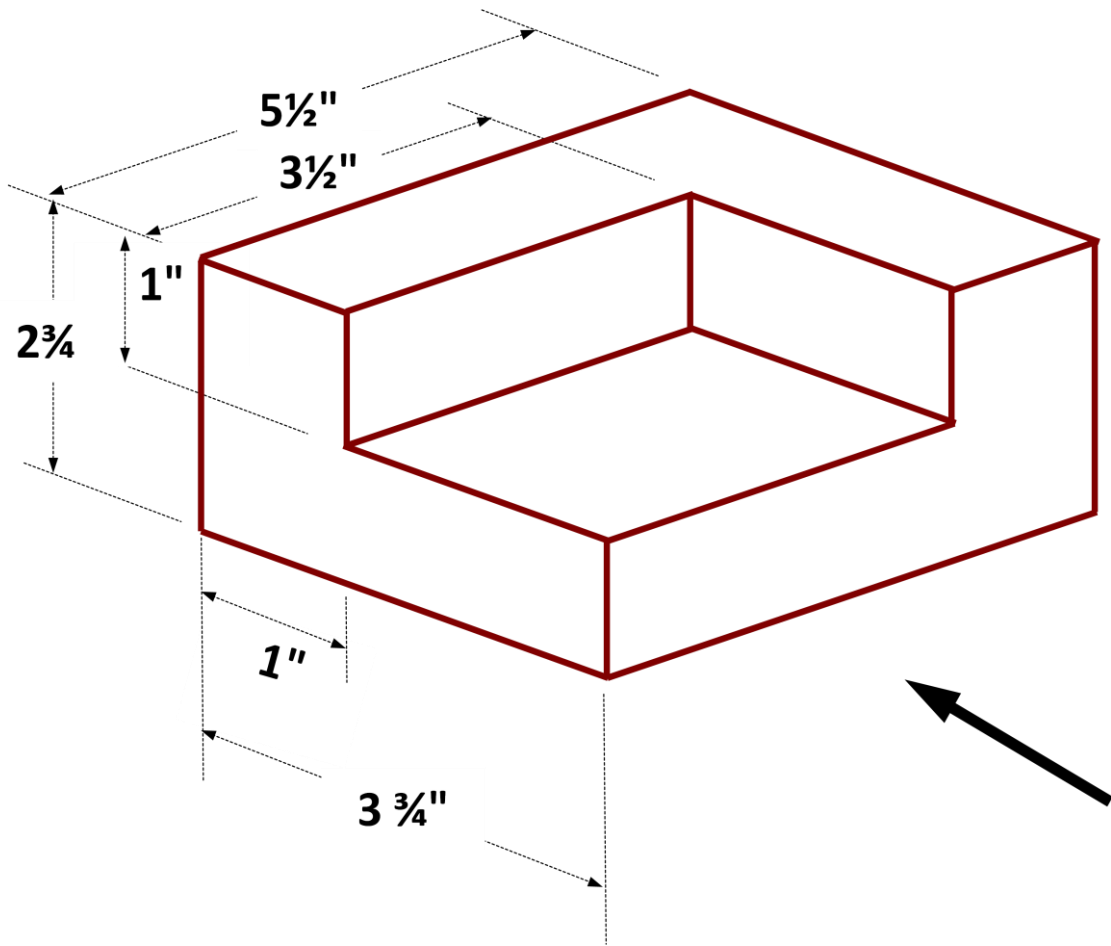

Assignment

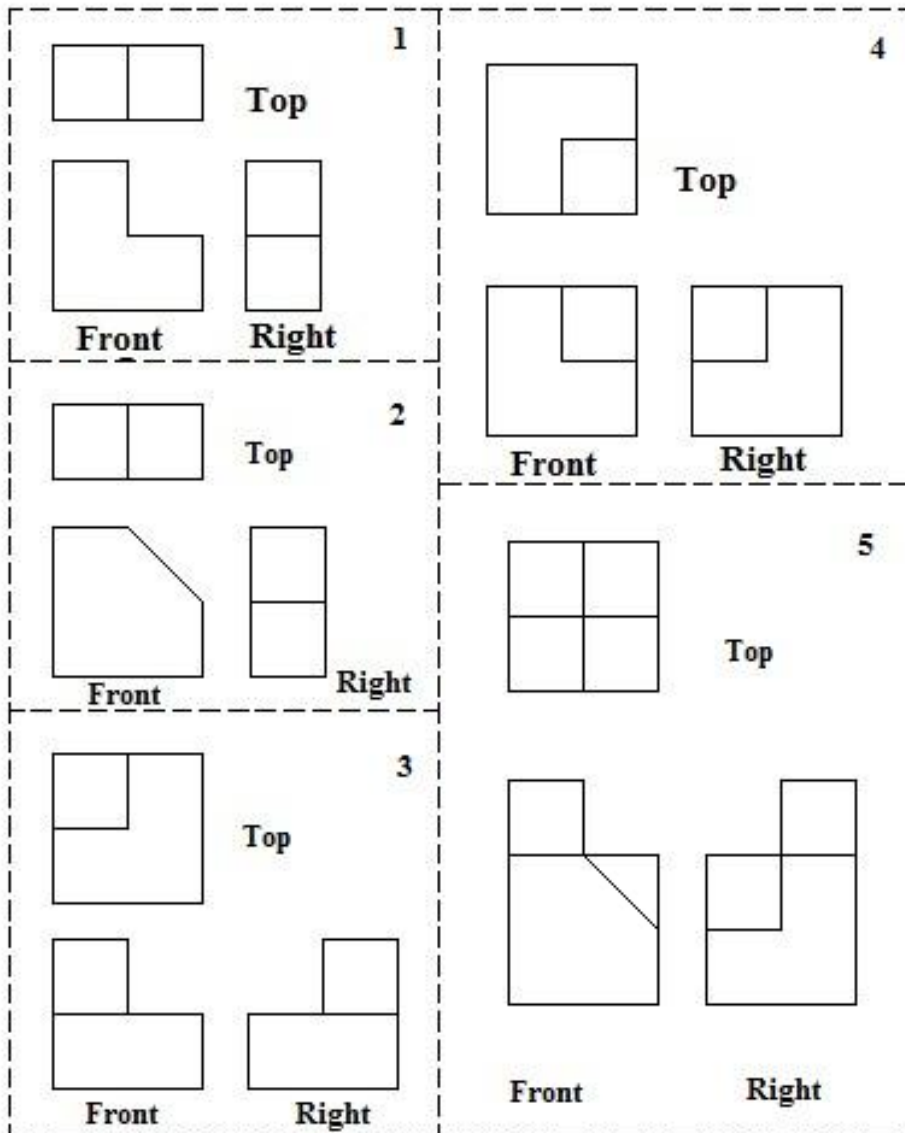

Topic 7
Structural drawing – Plan view, Elevation view and Cross sectional view



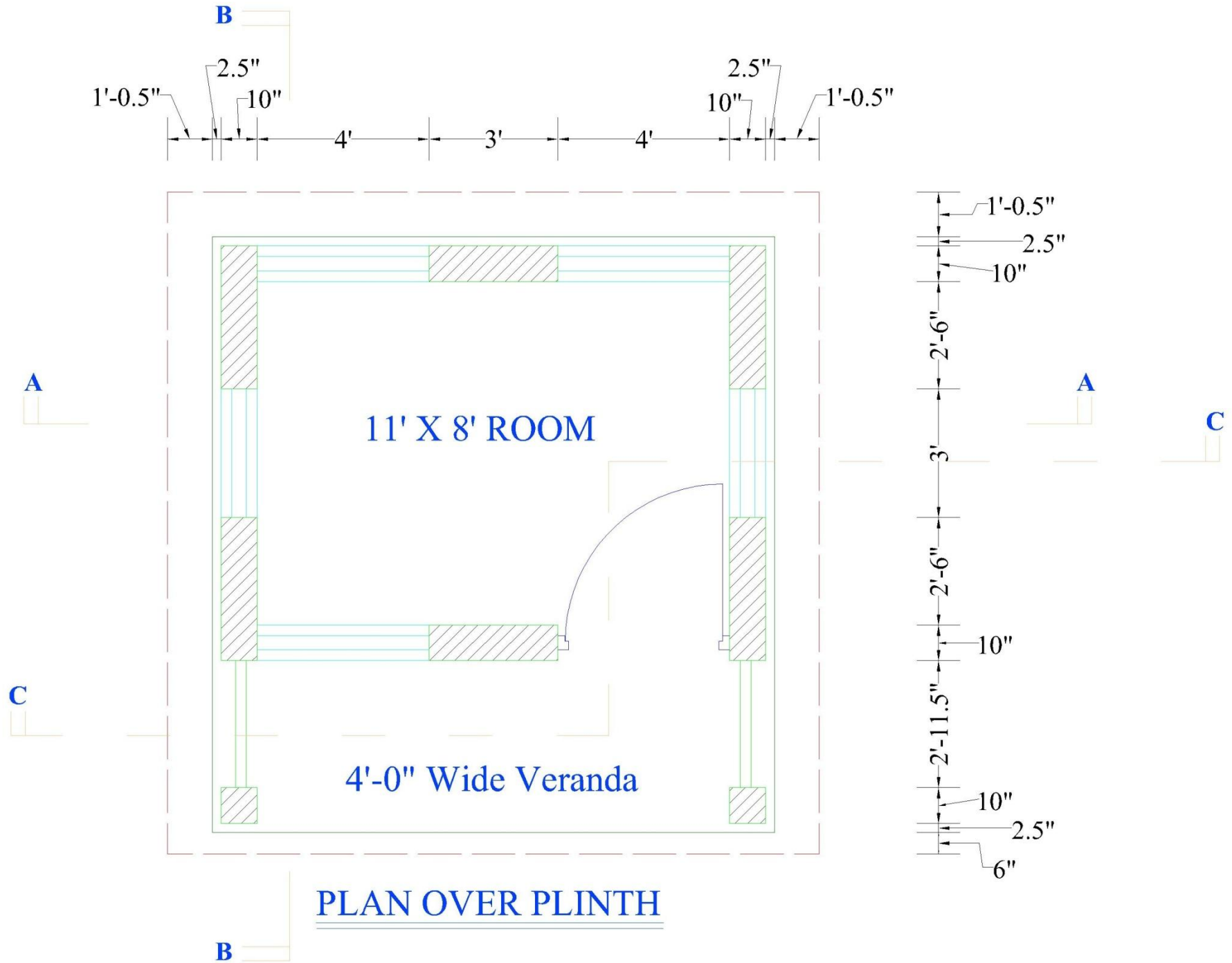

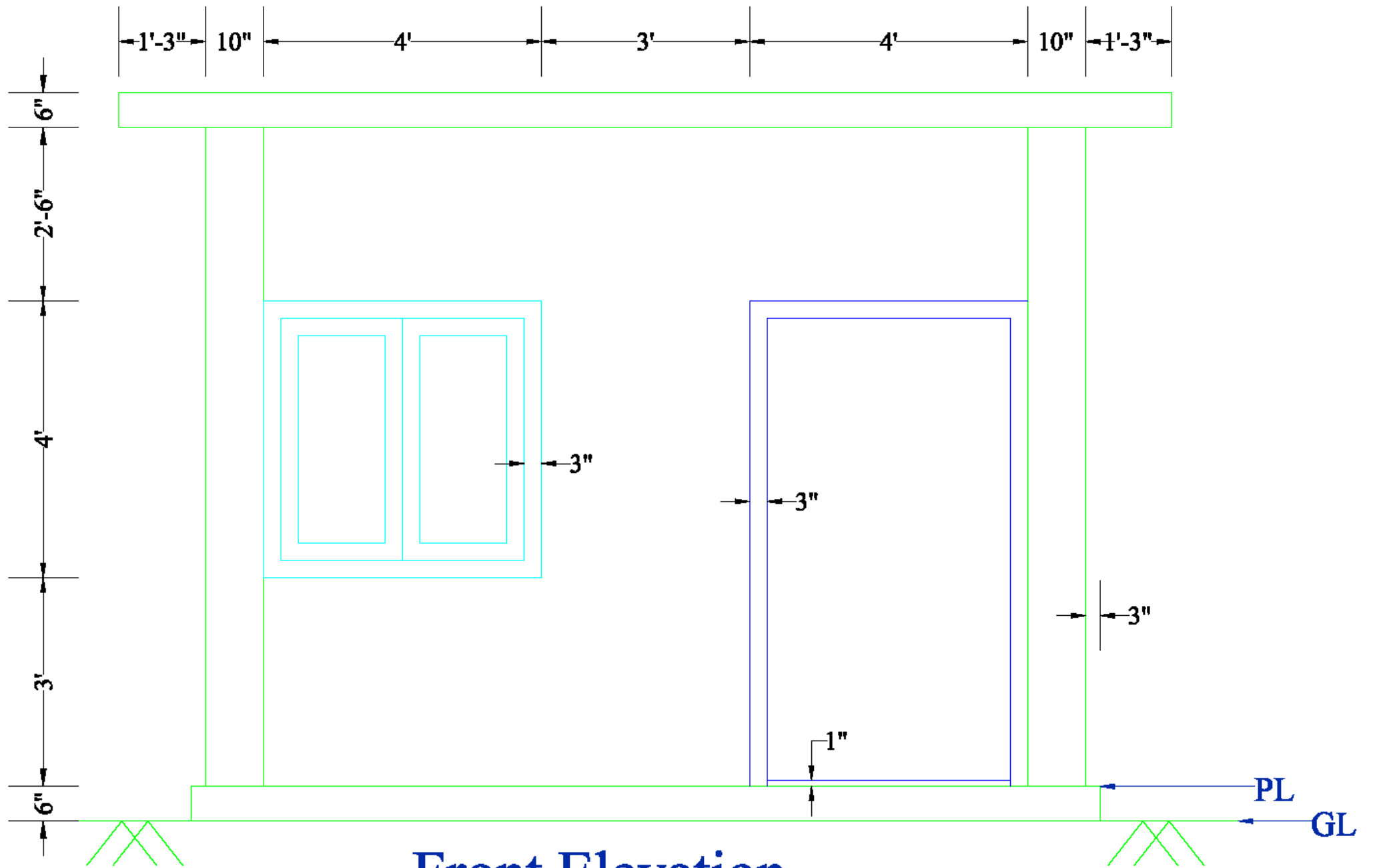

Front Elevation

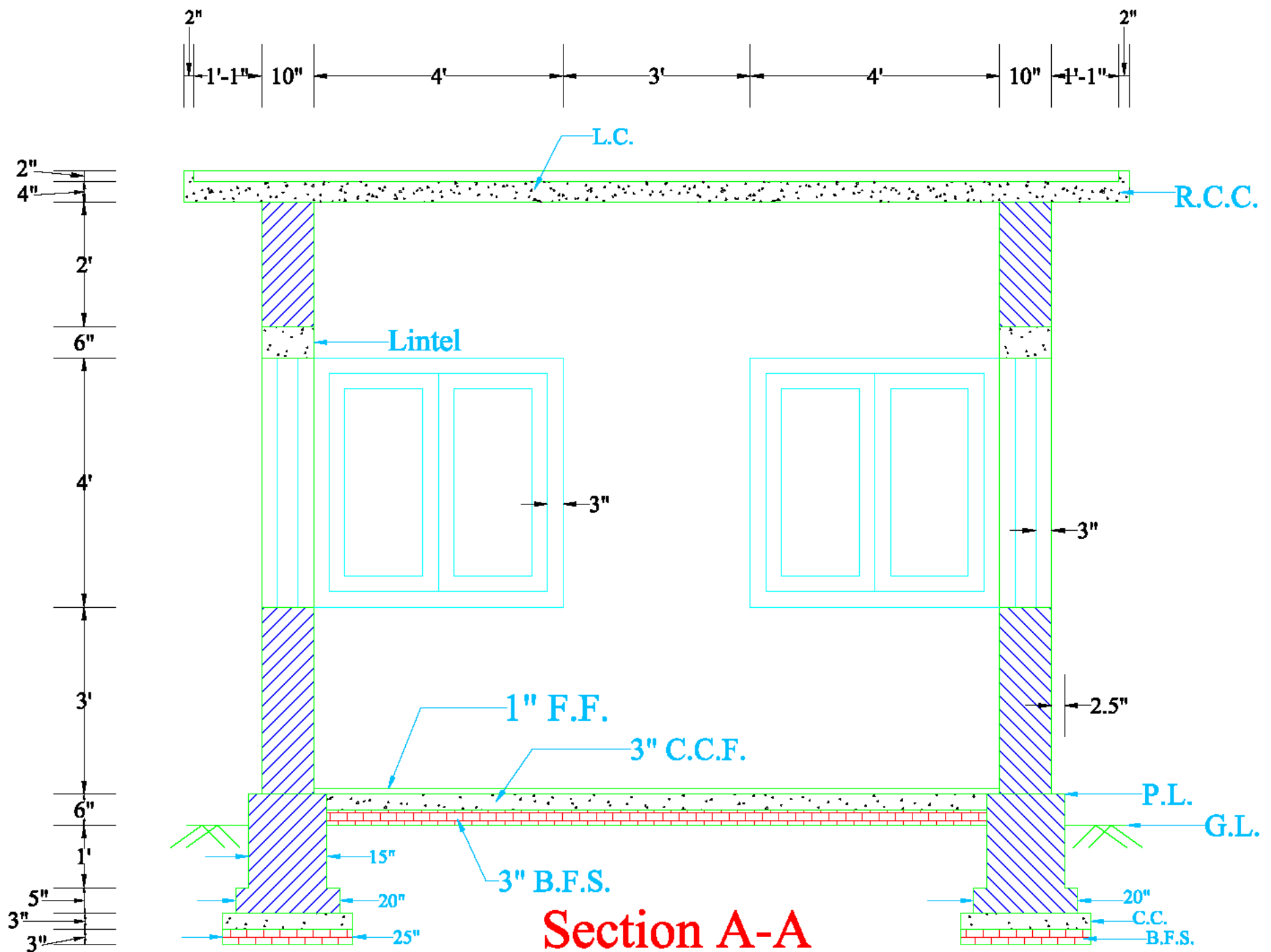

Section A-A

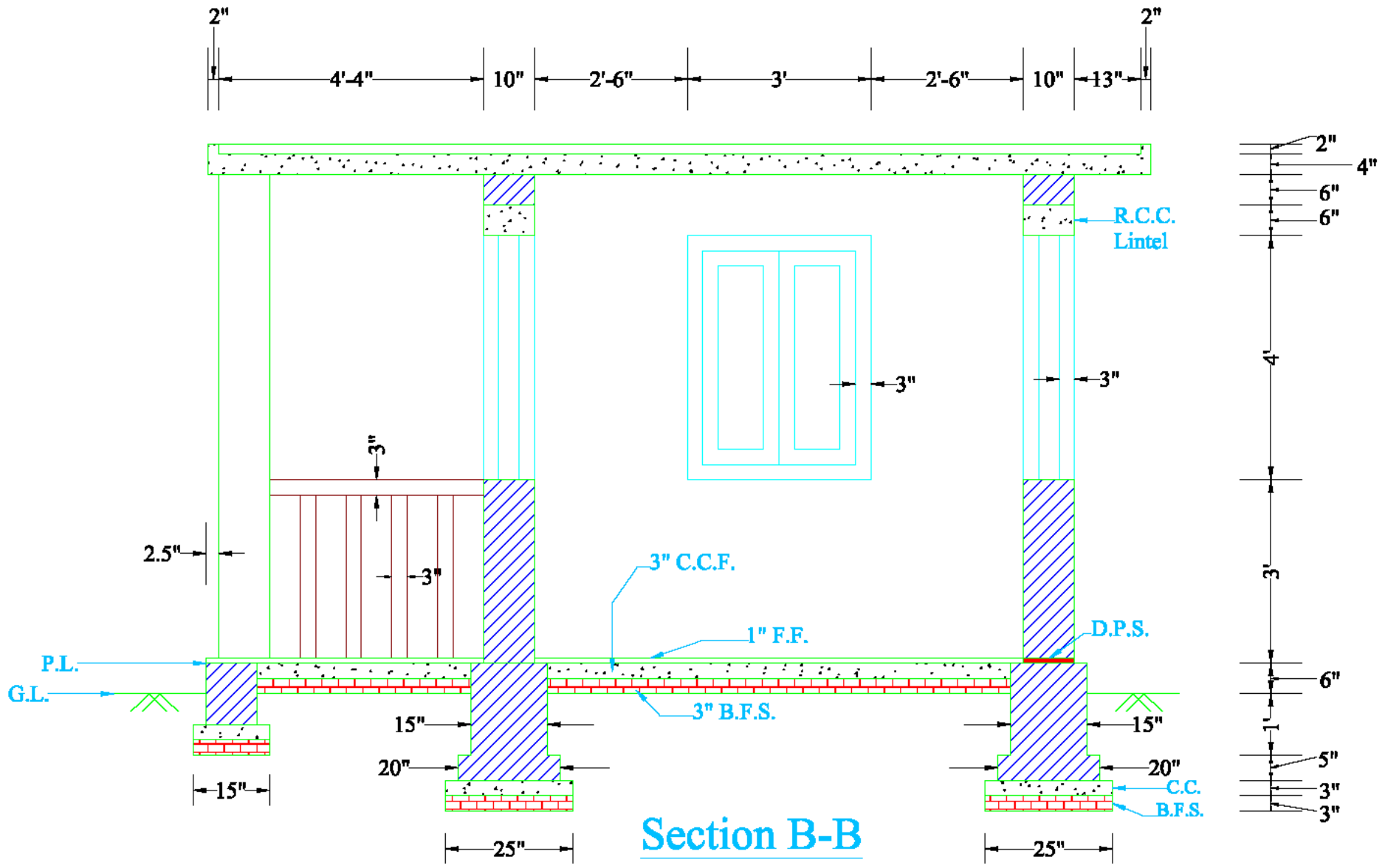

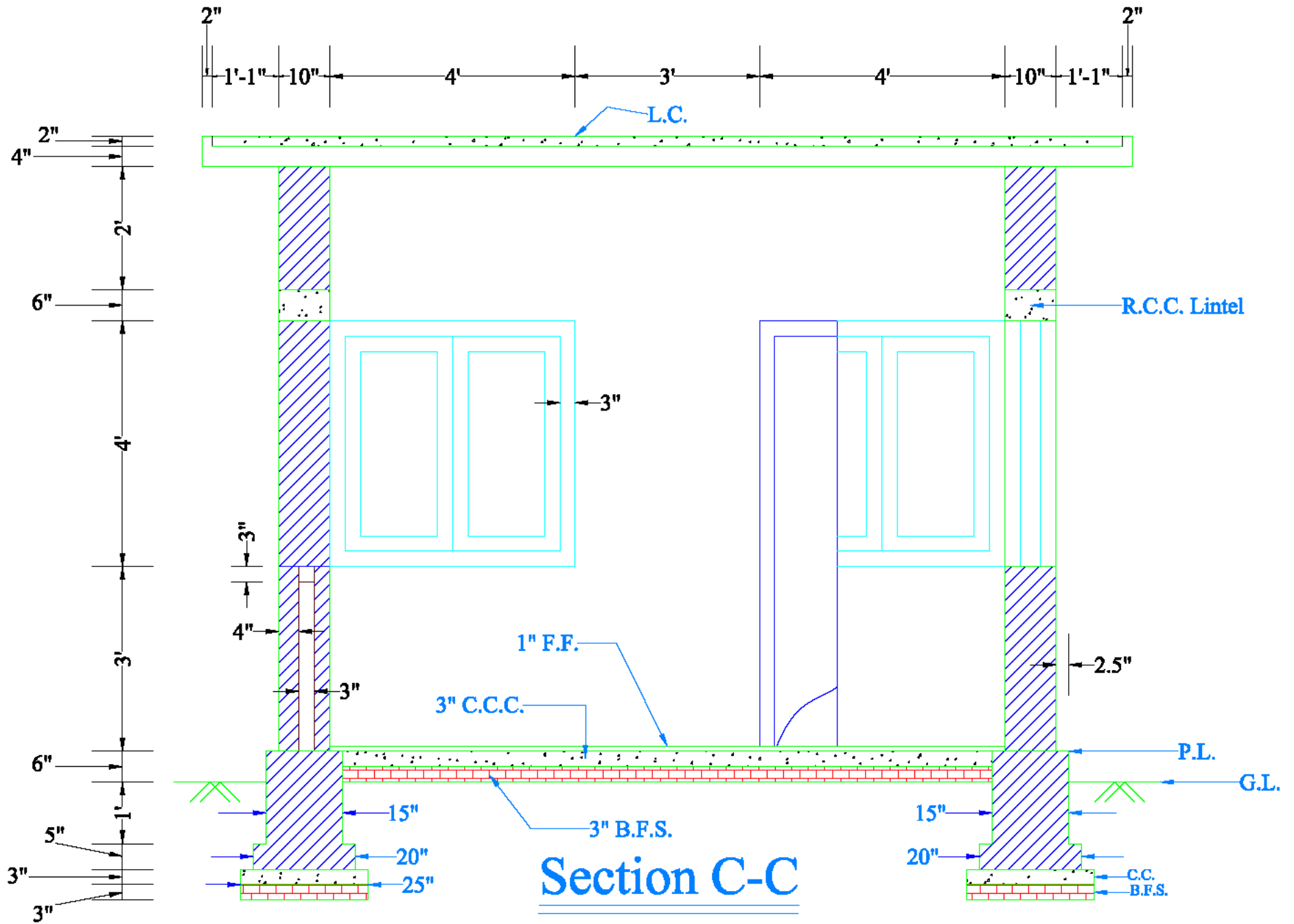

Topic 8
Structural drawing –Isolated footing and beam
longitudinal and cross sectional views

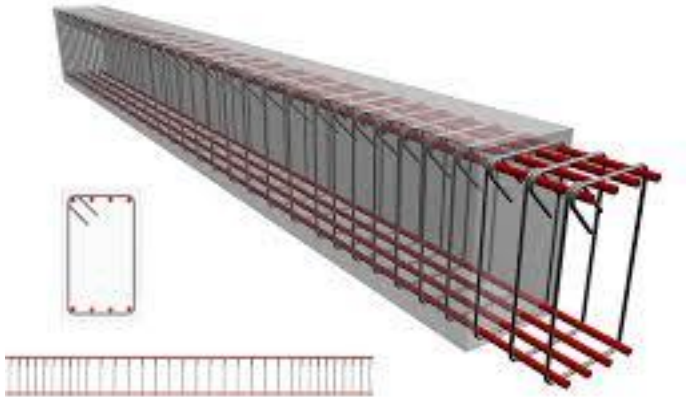

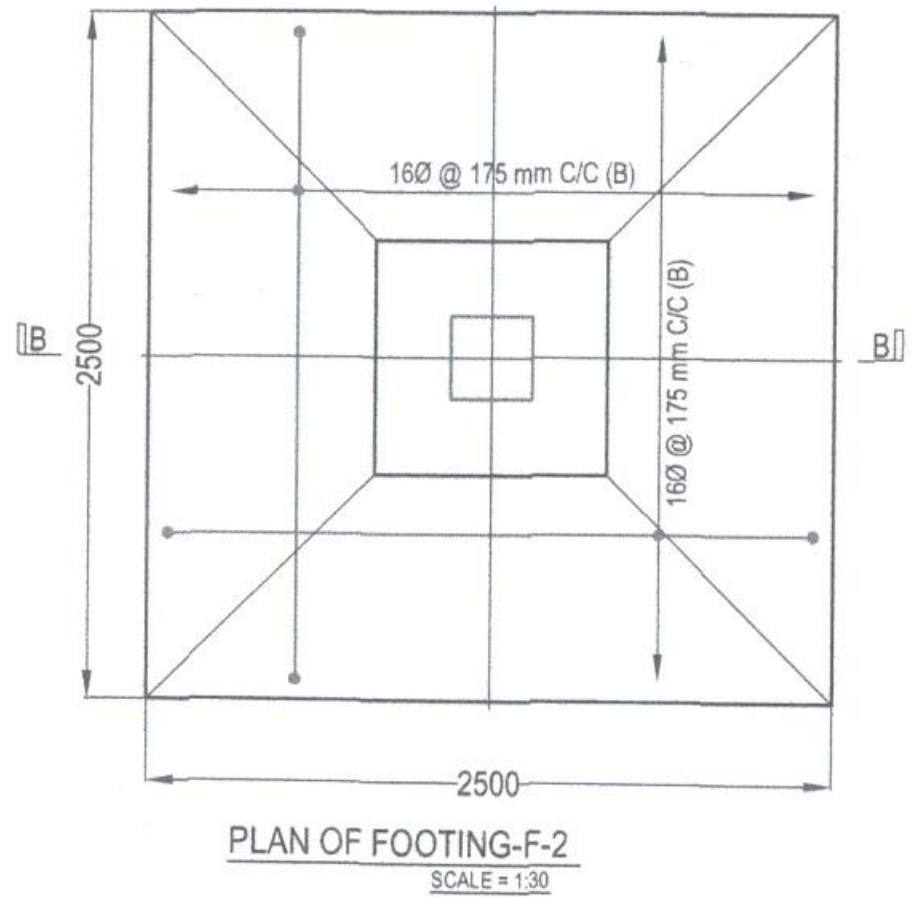
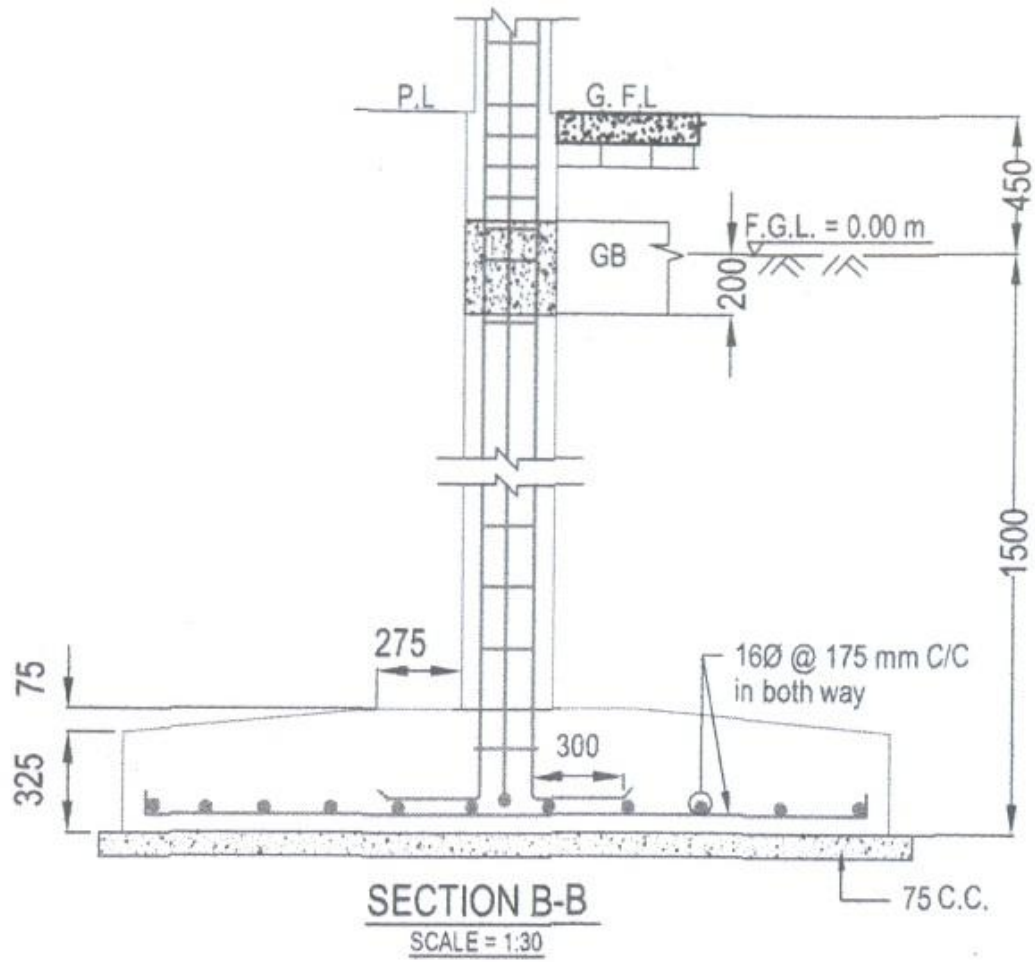

Cross Section of an Isolated column footing

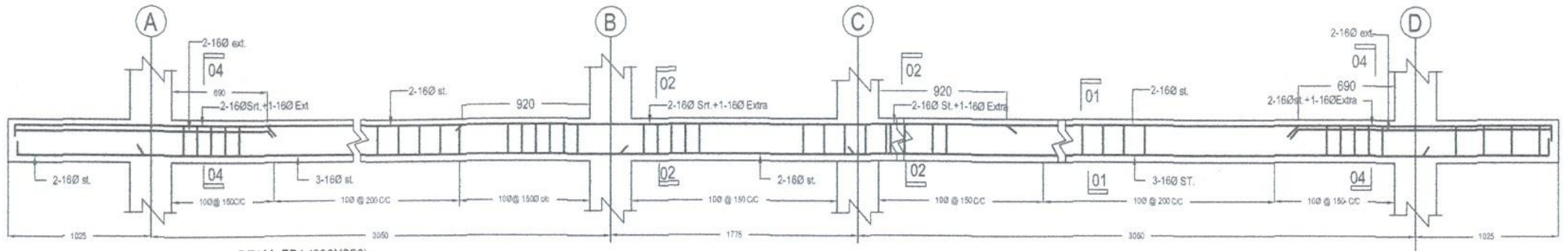

BEAM-FB4 (300X250)
Scale = 1:35

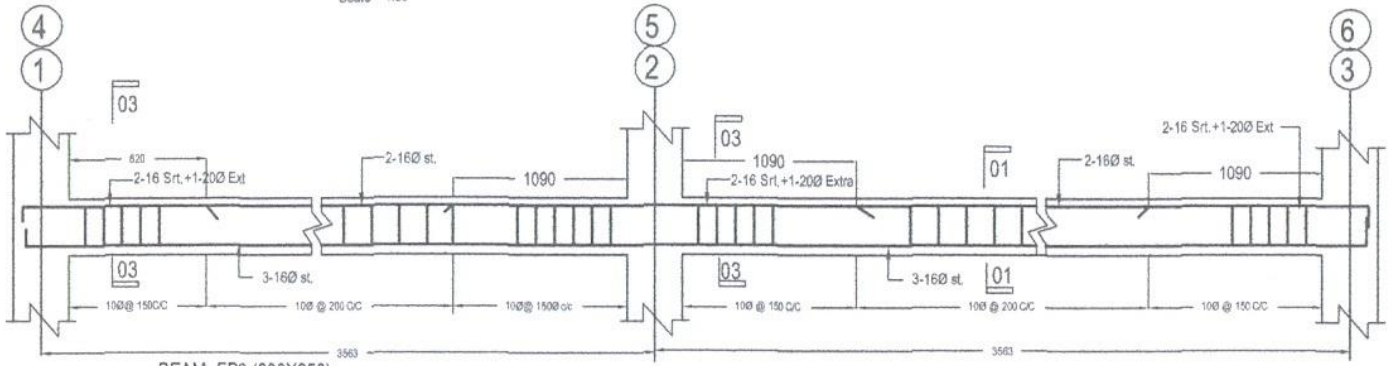

BEAM-FB2 (300X250)
Scale = 1:35

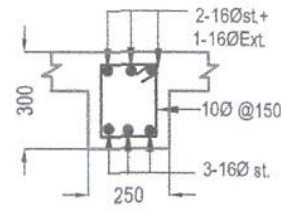

SEC:- 02-02
Scale = 1:20

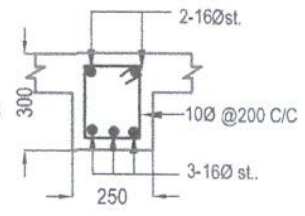

SEC:- 01-01
Scale = 1:20

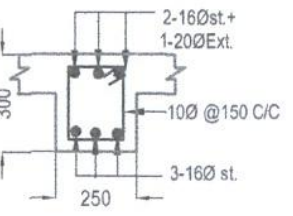

SEC:- 03-03
Scale = 1:20

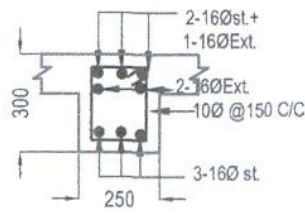

SEC:- 04-04
Scale = 1:20

Topic 9

Structural drawing – Slab and Stair reinforcement detailing



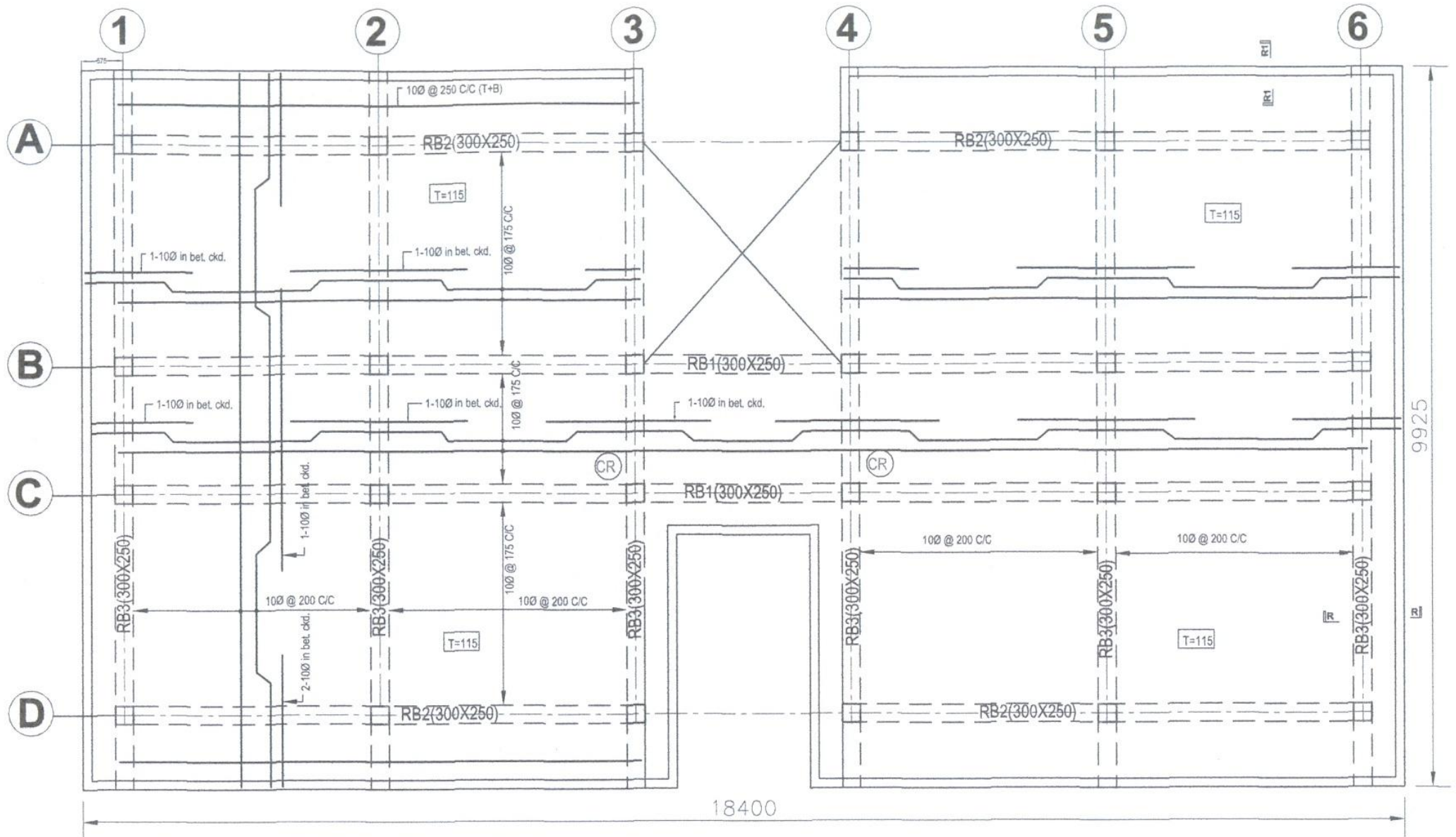

REINFORCEMENT DETAILS OF ROOF SLAB.

SCALE = 1:60

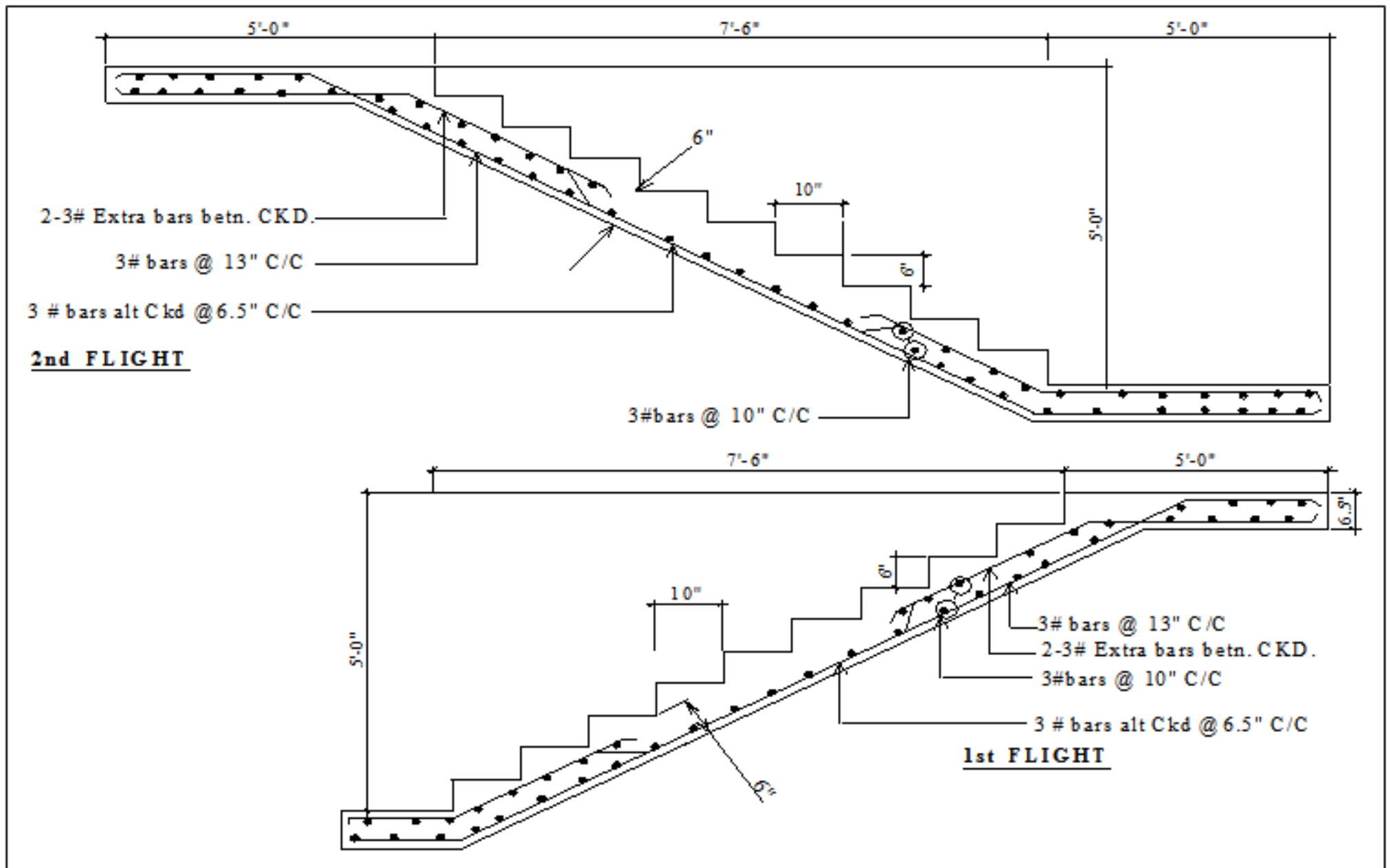

Appendix 1

Lab Report Format

1. All students must have a same colored printed **cover page**. The design of cover page is provided with the lab manual. Students have to compose only the course teacher's name and designation and their information.
2. An **index** is provided. It should be printed and set after the cover page. Table may be filled up by pen during each submission after that particular subject has been covered.
3. Each report must have a common **top page**. Only the experiment name and no. and the date may be filled up by pen. A top page design is provided.
4. **A4 papers** have to be used for preparing the lab report.



CE 100

Civil Engineering Drawing Sessional (Lab Report)



Prepared For
Name of Course Teacher
Designation of Course Teacher
&
Name of Course Teacher
Designation of Course Teacher

Prepared By
Name of Student
Student's ID
Year/ Semester
Group

INDEX

Topic no.	Topic Name	Date of Submission	Signature	Comments	Page no.

INDEX

Topic no.	Topic Name	Date of Submission	Signature	Comments	Page no.



CE 100

Civil Engineering Drawing Sessional (Lab Report)

Experiment No. :
Experiment Name:

Date of Performance:
Date of Submission:

Prepared For
Name of Course Teacher
Designation of Course Teacher
&
Name of Course Teacher
Designation of Course Teacher

Prepared By
Name of Student
Student's ID
Year/ Semester
Group

Appendix 2

Lab Instructions

1. All students must be present at the class just in time.
2. All students must have to submit the lab report just after the entrance and before the class start.
3. Lab reports have to be submitted serially according to Student's ID.
4. Strict discipline must be maintained in the classroom. Useless chattering and gossiping during class time in the teachers' presence is not acceptable under any circumstances whatsoever.